

Plan View - Top Slab

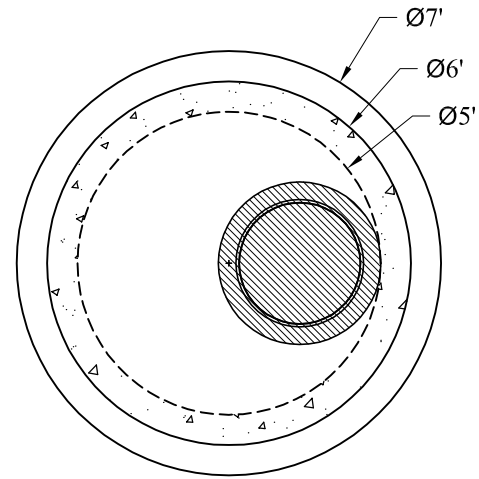

Plan View  
Optional Cast Iron Frame & Cover  
Adjust to Grade As Required

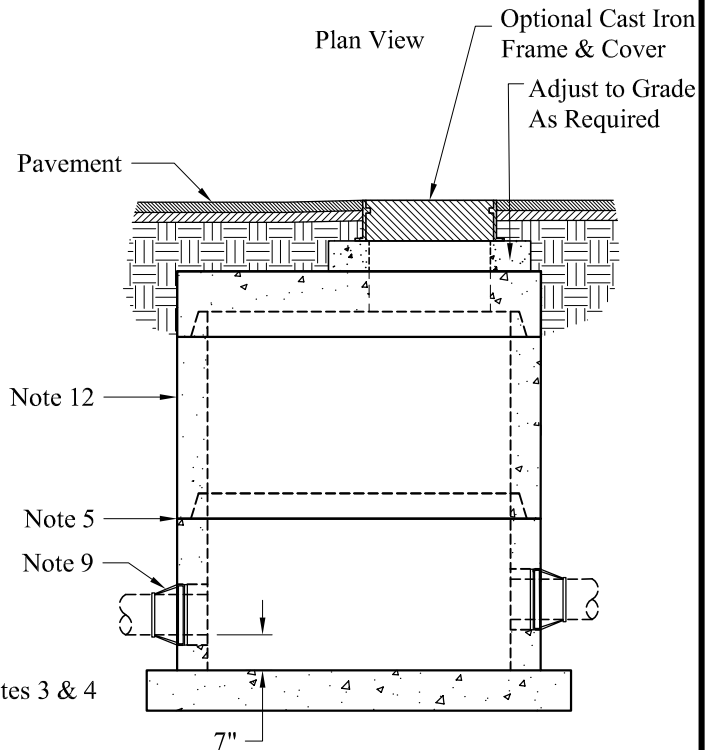
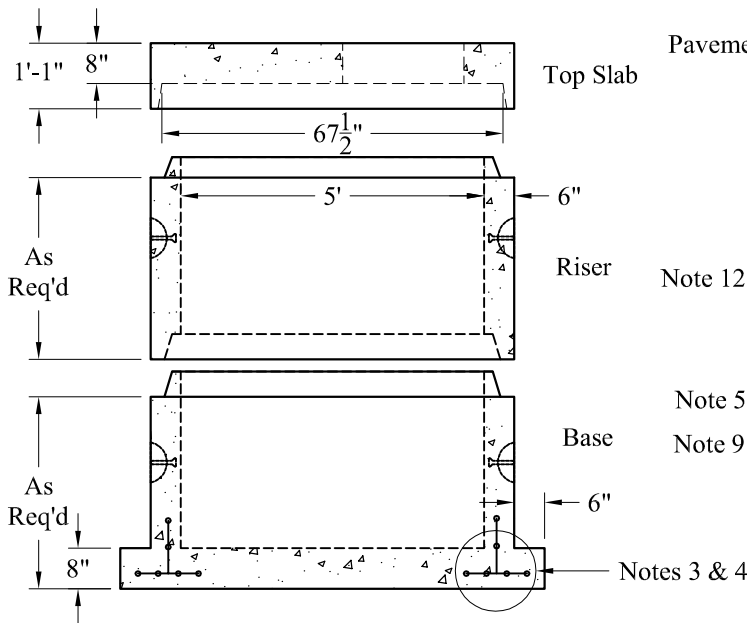

**General Notes**

1. Concrete:  $f_c = 4,000$  psi @ 28 Days Minimum, Type III Cement
2. HS-20 Design Loading Conforms to Latest Specifications  
ASTM C478, AASHTO M199 Precast Reinforced Concrete Manhole Sections
3. One Pour Monolithic Base Section
4. Steel Reinforcement Conforms to Latest ASTM Specification:  
ASTM A-615, Grade 60 Black Deformed Bars  
ASTM A-185 Welded Wire Fabric  
0.15 Sq. In./Lineal Ft. And 0.12 Sq. In.(Both Ways) Base Bottom
5. Butyl Rubber Joint Sealant Provided Conforms to ASTM C-990  
And Federal Spec SS-S-210A
6. 147 Gallons/VF
7. Holes & Elevations TBD
8. Sections Available in Increments of 6"
9. Booted Pipe Connections (If Used) Conform to ASTM C-923.  
Maximum Booted Connection Pipe Size is 30"
10. Maximum Pipe OD is 44" (36" RCP)
11. Plastic Manhole Steps (If Required) are Steel Reinforced  
Conforming to ASTM C-478
12. Asphaltic Exterior Coating Available

**Est Weights:**

Top Slab:	3,040 Lbs
Wt/VF:	1,280 Lbs
Floor:	1,939 Lbs
Extended Base:	1,010 Lbs

Phoenix  
Precast  
Products

5' Diameter  
Sanitary Manhole  
Extended Base