

Plan View - Top Slab

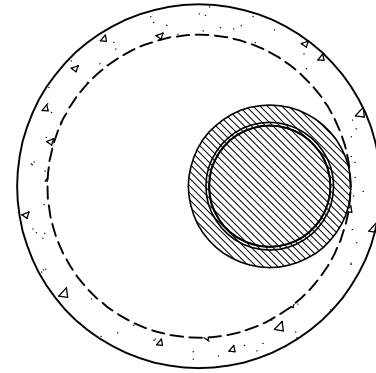

Plan View

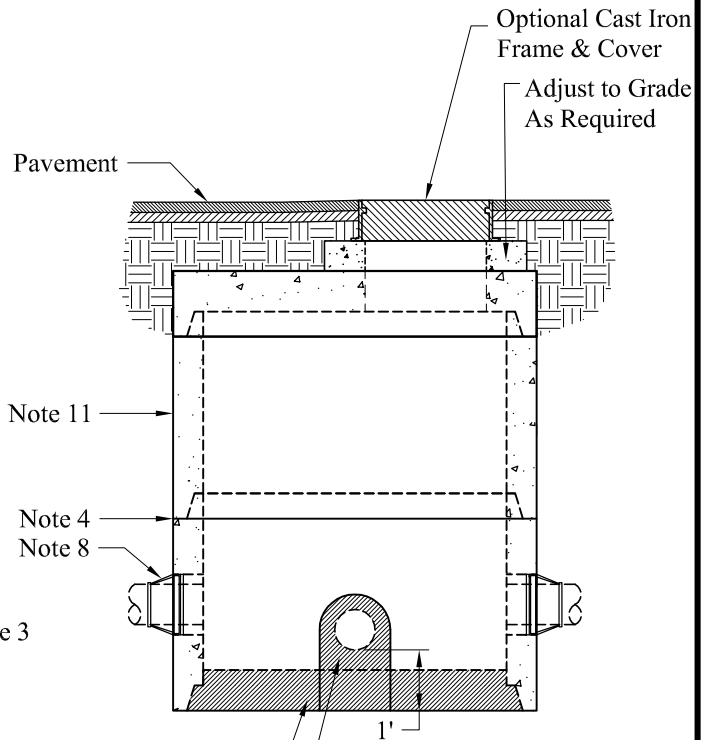
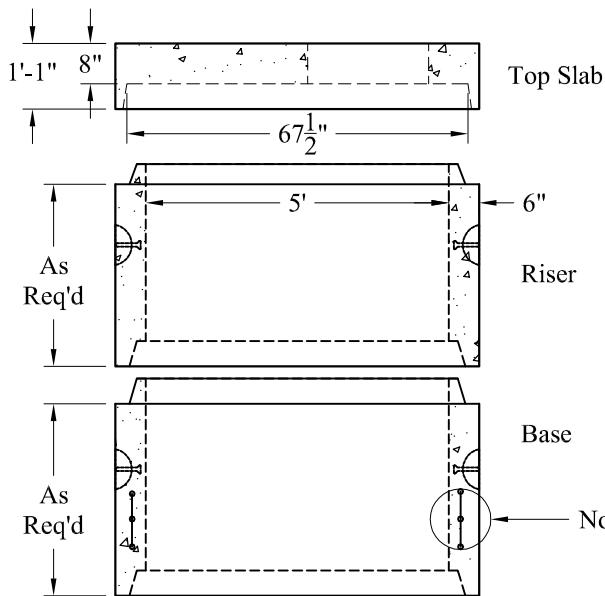

General Notes

1. Concrete: $f_c = 4,000$ psi @ 28 Days Minimum, Type III Cement
2. HS-20 Design Loading Conforms to Latest Specifications ASTM C478, AASHTO M199 Precast Reinforced Concrete Manhole Sections
3. Steel Reinforcement Conforms to Latest ASTM Specification: ASTM A-615, Grade 60 Black Deformed Bars
ASTM A-185 Welded Wire Fabric
0.15 Sq. In./Lineal Ft. And 0.12 Sq. In.(Both Ways) Base Bottom
4. Butyl Rubber Joint Sealant Provided Conforms to ASTM C-990 And Federal Spec SS-S-210A
5. 147 Gallons/VF
6. Holes & Elevations TBD
7. Sections Available in Increments of 6"
8. Booted Pipe Connections (If Used) Conform to ASTM C-923. Maximum Booted Connection Pipe Size is 30"
9. Maximum Pipe OD is 44" (36" RCP)
10. Plastic Manhole Steps (If Required) are Steel Reinforced Conforming to ASTM C-478
11. Asphaltic Exterior Coating Available

Floor is Cast in Place
By Others
After Setting Manhole
Mortar Joint by Others

Est Weights:

Top Slab: 3,040 Lbs
Wt/VF: 1,280 Lbs

Phoenix
Precast
Products

5' Diameter
Sanitary Manhole
Doghouse