

Plan View - Top Slab

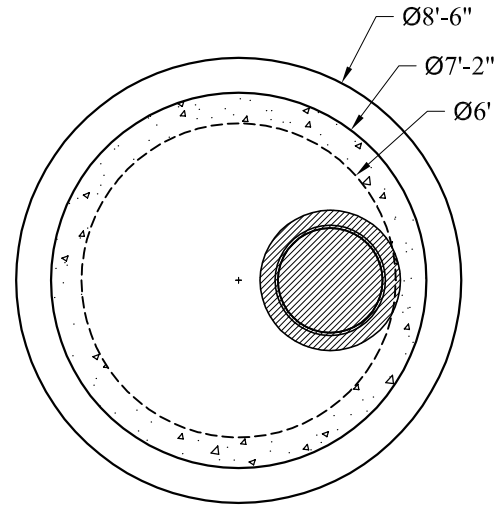

Plan View

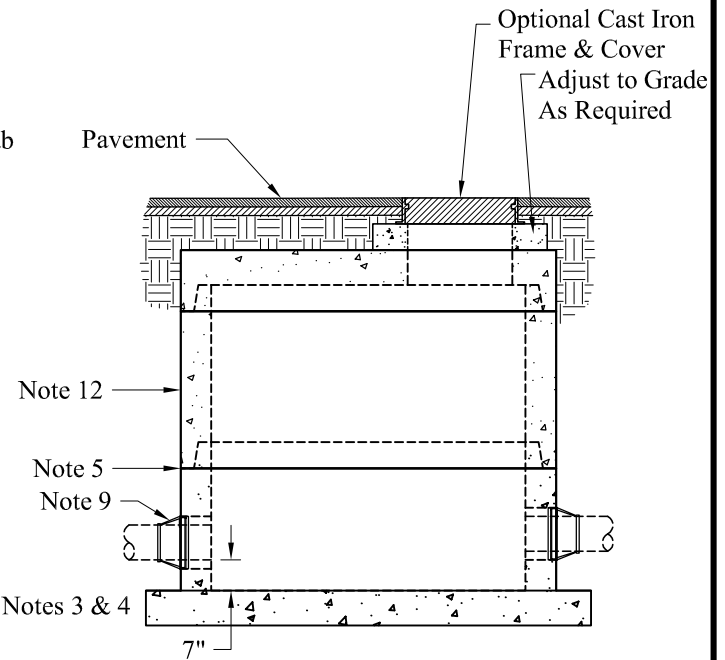
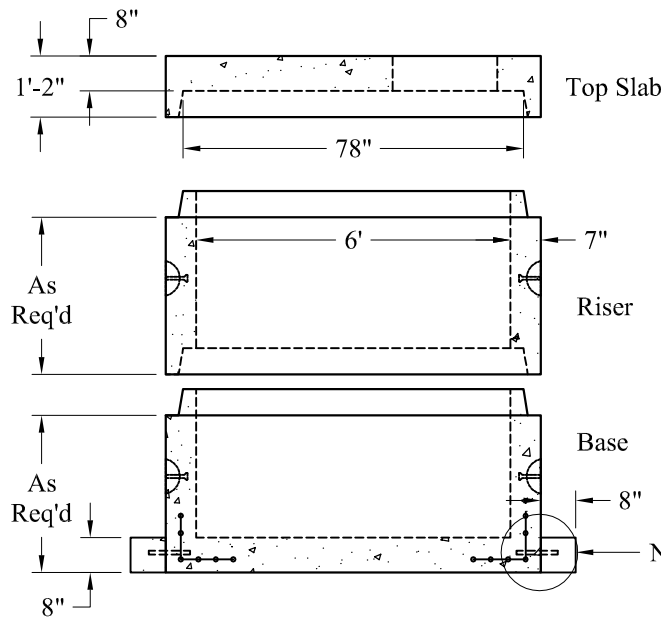

General Notes

1. Concrete: $f_c = 4,000$ psi @ 28 Days Minimum, Type III Cement
2. HS-20 Design Loading Conforms to Latest Specifications
ASTM C478, AASHTO M199 Precast Reinforced Concrete Manhole Sections
3. Drill & Dowel Base Before Extension is Poured
4. Steel Reinforcement Conforms to Latest ASTM Specification:
ASTM A-615, Grade 60 Black Deformed Bars
ASTM A-185 Welded Wire Fabric
0.18 Sq. In./Lineal Ft. And 0.12 Sq. In.(Both Ways) Base Bottom
5. Butyl Rubber Joint Sealant Provided Conforms to ASTM C-990
And Federal Spec SS-S-210A
6. 212 Gallons/VF
7. Holes & Elevations TBD
8. Sections Available in Increments of 6"
9. Booted Pipe Connections (If Used) Conform to ASTM C-923.
Maximum Booted Connection Pipe Size is 36" RCP
10. Maximum Pipe OD is 59" (48" RCP)
11. Plastic Manhole Steps (If Required) are Steel Reinforced
Conforming to ASTM C-478
12. Asphaltic Exterior Coating Available

Est Weights:

Top Slab:	4,000 Lbs
Wt/VF:	1,776 Lbs
Floor:	2,240 Lbs
Extended Base:	1,930 Lbs

Phoenix
Precast
Products

6' Diameter
Sanitary Manhole
Extended Base