

1-800-639-2199

Fax (603) 224-2927

Tanks\Standard\1,000 Gal\1000 Gal LD Holding Tank Sales

Phoenix Precast Products

Phoenix Precast Products

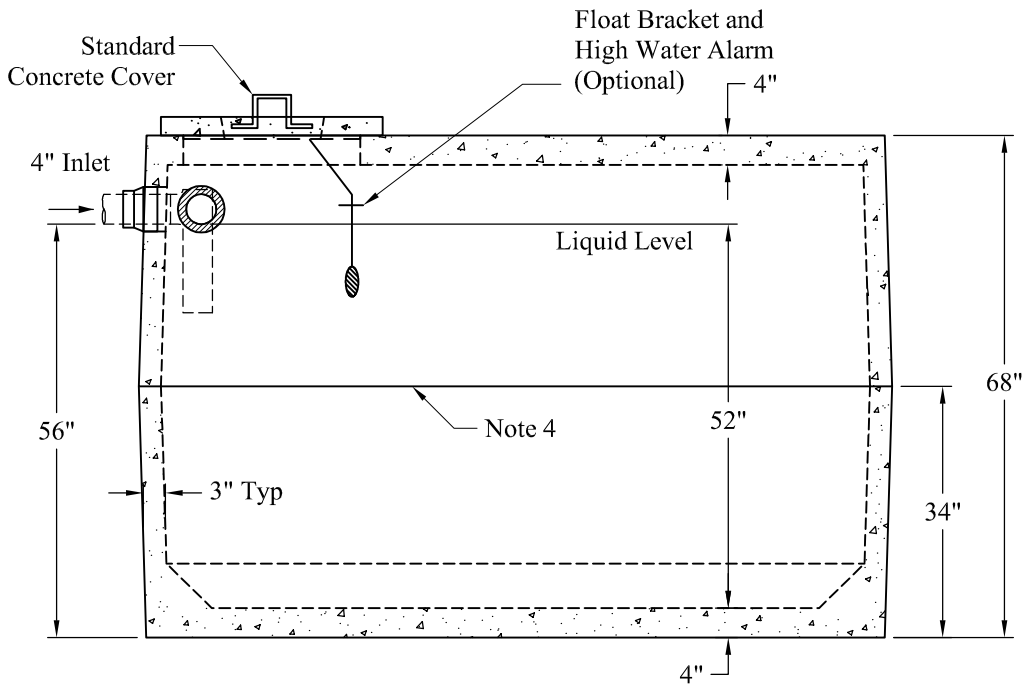
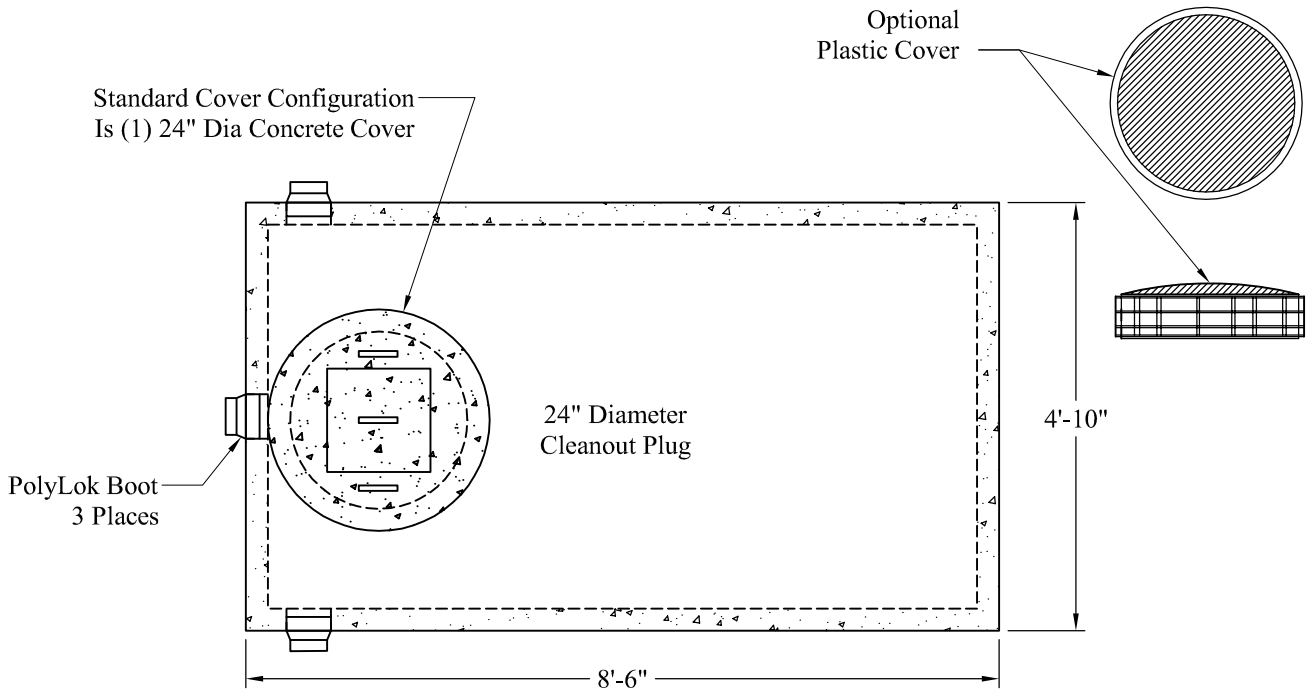

Est. Weight:
 Upper: 4,340 Lbs
 Lower: 4,600 Lbs
 Total: 8,940 Lbs

General Notes

1. Steel Reinforcement Conforms to Latest ASTM Specifications: ASTM-A615 Grade 60 Rebar
2. Concrete: fc = 4,000 psi @ 28 Days Minimum
3. Flexible Sleeves Used On All Pipe Openings
4. Butyl Rubber Joint Sealant Provided
5. Internal PVC Baffles Available
- Inlet: Shall Penetrate at Least 9" Below the Liquid Level.
6. LD Tanks: 3' Cover Max, Non-Traffic

Phoenix
Precast
Products

1,000 Gallon
LD Holding Tank

P/N: HT-1000RLD