

1-800-639-2199

Fax (603) 224-2927

Tanks(Standard)2000_Gal_H20(2000 Gallon H2O Tank Presby Maze Sales

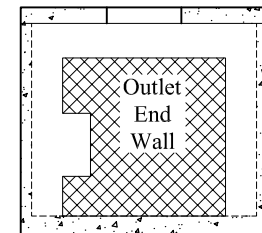
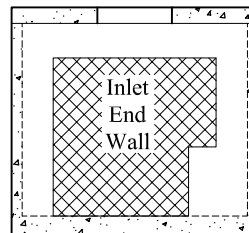
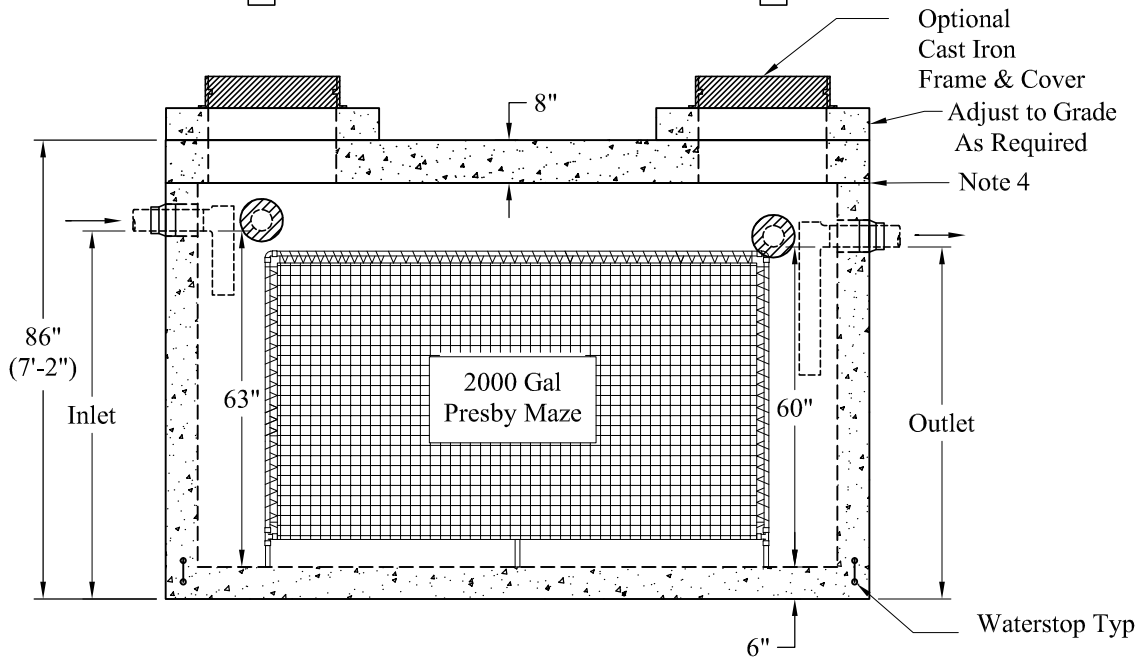
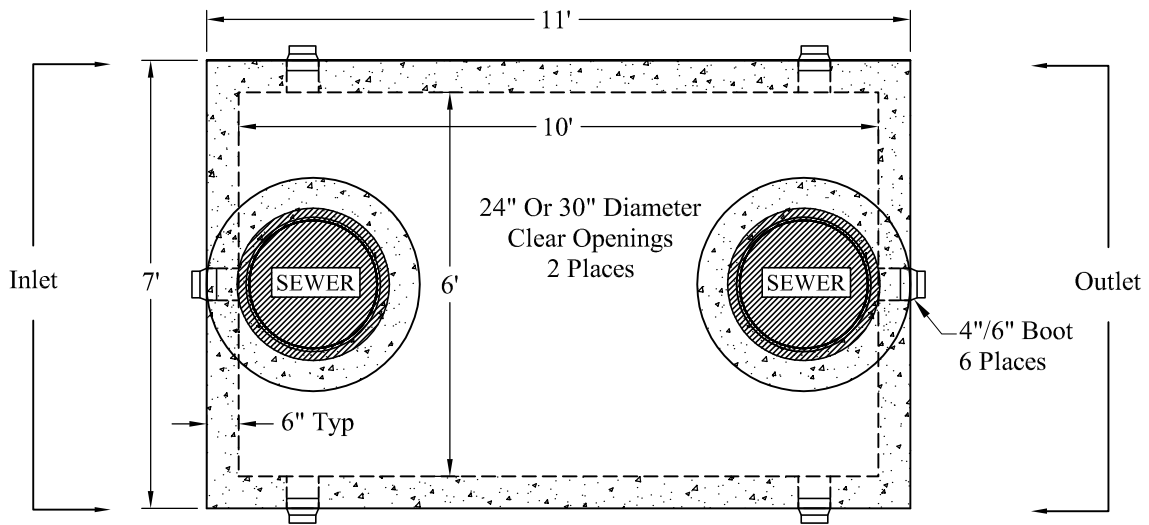

End Views of Maze (NTS)

Liquid Levels: 6' x 10' = 450 Gals/VF

4" PVC = 2,250 Gals Inverts: Inlet-69" Outlet-66"

6" PVC = 2,214 Gals Inverts: Inlet-68" Outlet-65"

General Notes:

1. Steel Reinforcement Conforms to Latest ASTM Specifications: ASTM-A615 Grade 60 Rebar
2. Concrete: $f_c = 5,000$ psi @ 28 Days Minimum
3. Flexible Sleeves Provided On All Pipe Connections
4. Butyl Rubber Joint Sealant Provided
5. Internal PVC Baffles Available Upon Request
- Inlet: Shall Penetrate at Least 9" Below the Liquid Level, But Not Deeper Than the Outlet Baffle.
- Outlet: Shall Extend Below the Surface of the Liquid Equal to 40% of the Liquid Depth (24").
6. Design Loading: AASHTO-HS20-44, ASTM C-890-06
7. Design Specified As: ASTM C-1227-08, ASTM C-913-08
8. Other Inlet/Outlet Pipe Sizes Available

Est Weights:

Top Slab -	7,100 Lbs
Base -	20,800 Lbs
Total:	27,900 Lbs

**Phoenix
Precast
Products**

**2,000 Gallon HS-20
Tank w/ Presby Maze**

P/N: ST-2000H20

Phoenix Precast Products

Phoenix Precast Products