

Pumps and Related Accessories are Optional.
 Junction Box and Electrical Connections
 Installed by Others

Pump Stations (Standard) 3 Ft Dia. 3 x 3 Ft 100 Gal LD PC

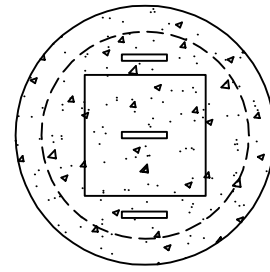

Optional Ø24" Cover

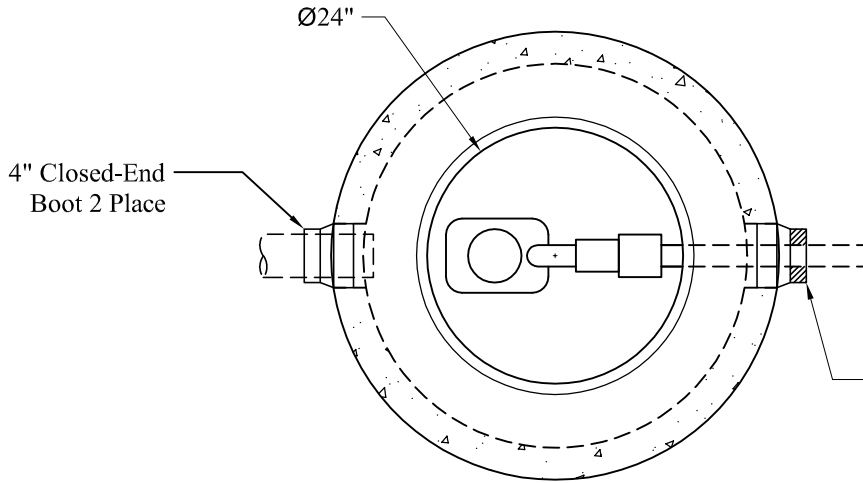
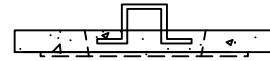

NOTE: A Pipe Bushing Will Be Required
 On All Boots with Pipes Less Than 4"

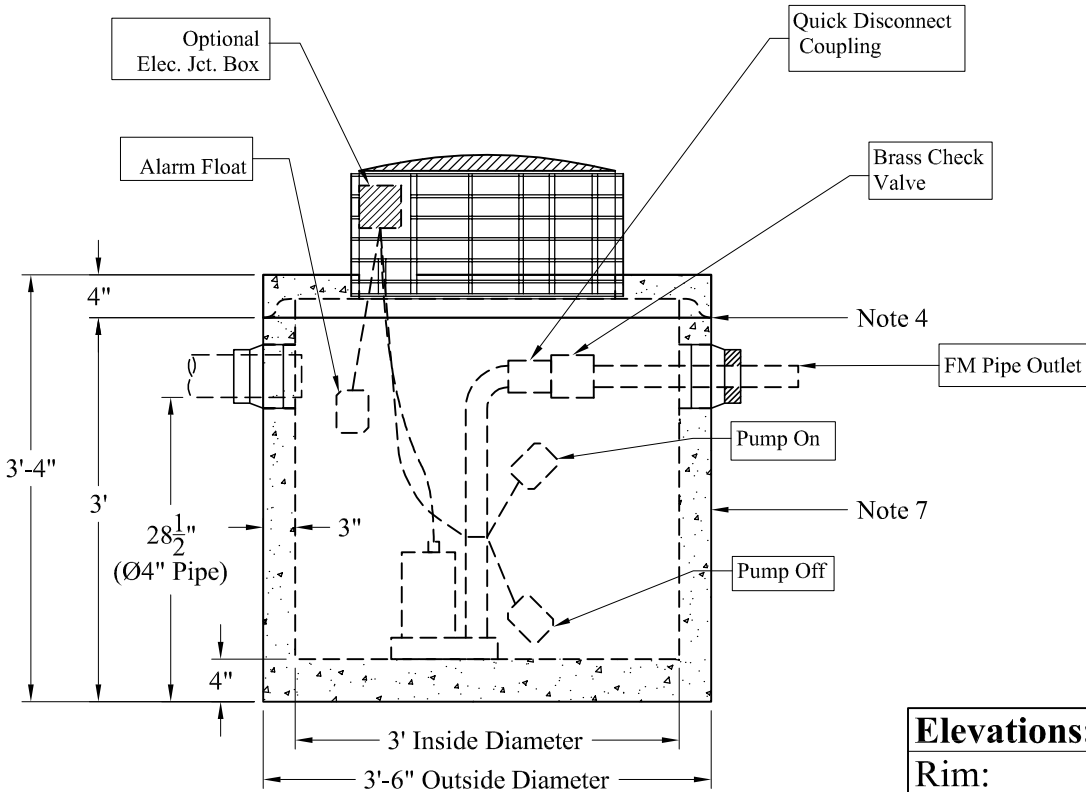

Elevations:	
Rim:	
Invert In:	
Alarm On:	
Pump On:	
Pump Off:	
Inside Floor:	

General Notes

- 1.) Reinforcement Steel: ASTM A-615, Grade 60
- 2.) Concrete: $f_c = 4,000$ psi @ 28 Days Minimum
- 3.) Liquid Capacity: 50 Gallons/VF (4 Gallons/Inch)
- 4.) Butyl Rubber Joint Sealant Provided
- 5.) Larger Volume Available
- 6.) Flexible Boots Provided
- 7.) Exterior Coating Available

Est. Weight:

Cover:	100 Lbs
Top Slab:	255 Lbs
Base:	1,500 Lbs
Total:	1,855 Lbs

Phoenix
 Precast
 Products

Typical 3' x 3' LD
 100 Gallon
 Pump Chamber

Phoenix Precast Products

Phoenix Precast Products