

1-800-639-2199

Fax (603) 224-2927

Tanks\500 Gal\500 Gal LD Septic Tank

Phoenix Precast Products

Phoenix Precast Products

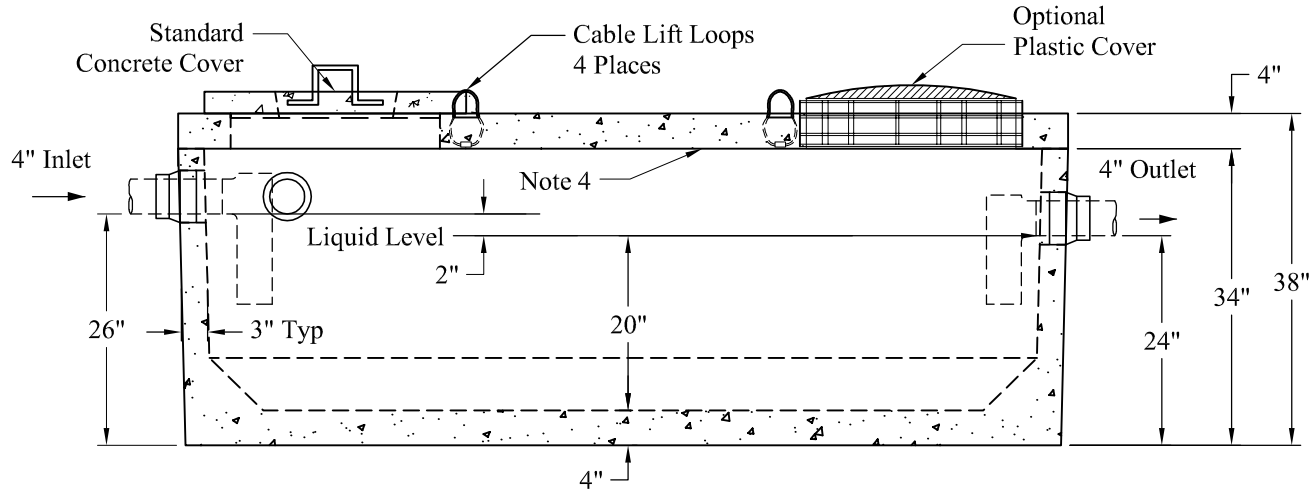
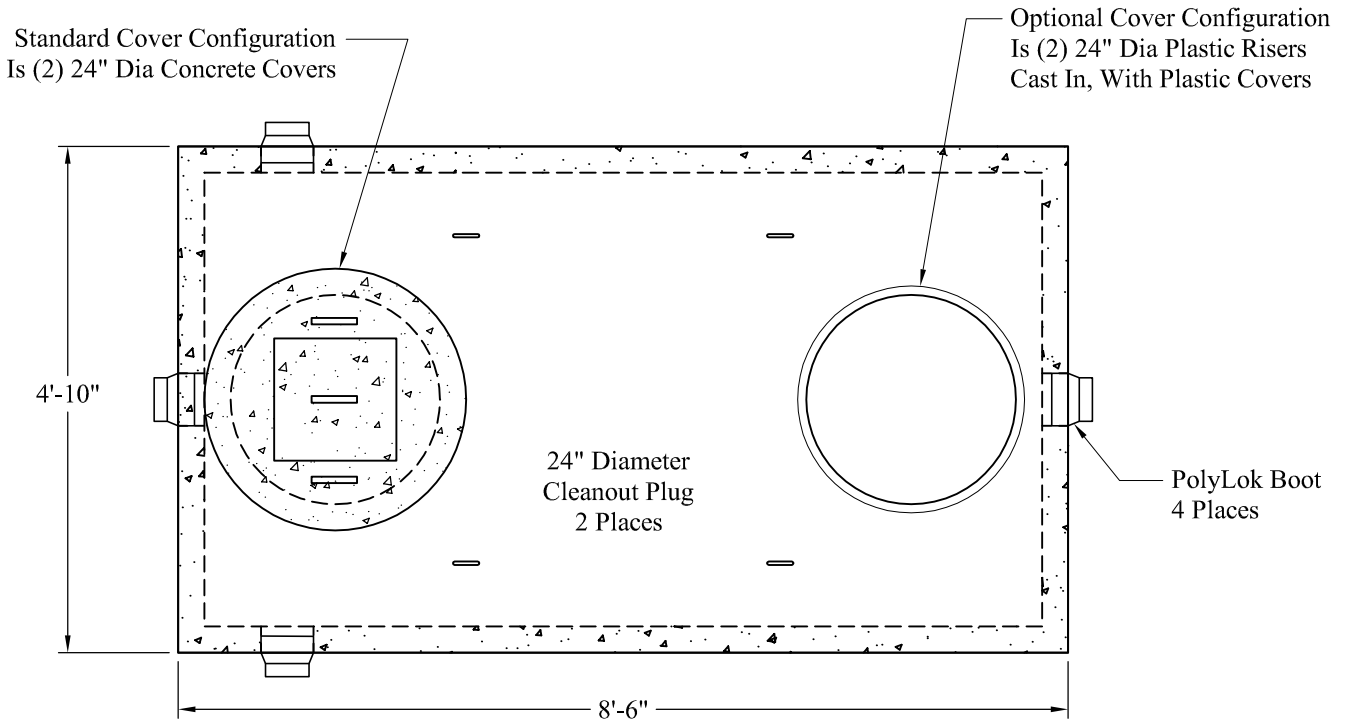

General Notes

1. Steel Reinforcement Conforms to Latest ASTM Specifications: ASTM-A615 Grade 60 Rebar
 2. Concrete: $f_c = 4,000$ psi @ 28 Days Minimum
 3. Flexible Sleeves Used On All Pipe Openings
 4. Butyl Rubber Joint Sealant Provided
 5. Internal PVC Baffles Available
- Inlet: Shall Penetrate at Least 8" Below the Liquid Level, But Not Deeper Than the Outlet Baffle.
- Outlet: Shall Extend Below the Surface of the Liquid Equal to 40% of the Liquid Depth (8").
6. LD Tanks: 3' Cover Max, Non-Traffic

Est Weight:
 Top Slab: 1,700 Lbs
 Base: 4,600 Lbs
 Total 5,300 Lbs

Phoenix
Precast
Products

500 Gallon
Top Seam
LD Septic Tank

P/N: ST-500LD