

1-800-639-2199

Fax (603) 224-2927

Tanks\Standard\1500 Gal Ledge\1500 Gal HD Ledge Septic Tank

Phoenix Precast Products

Phoenix Precast Products

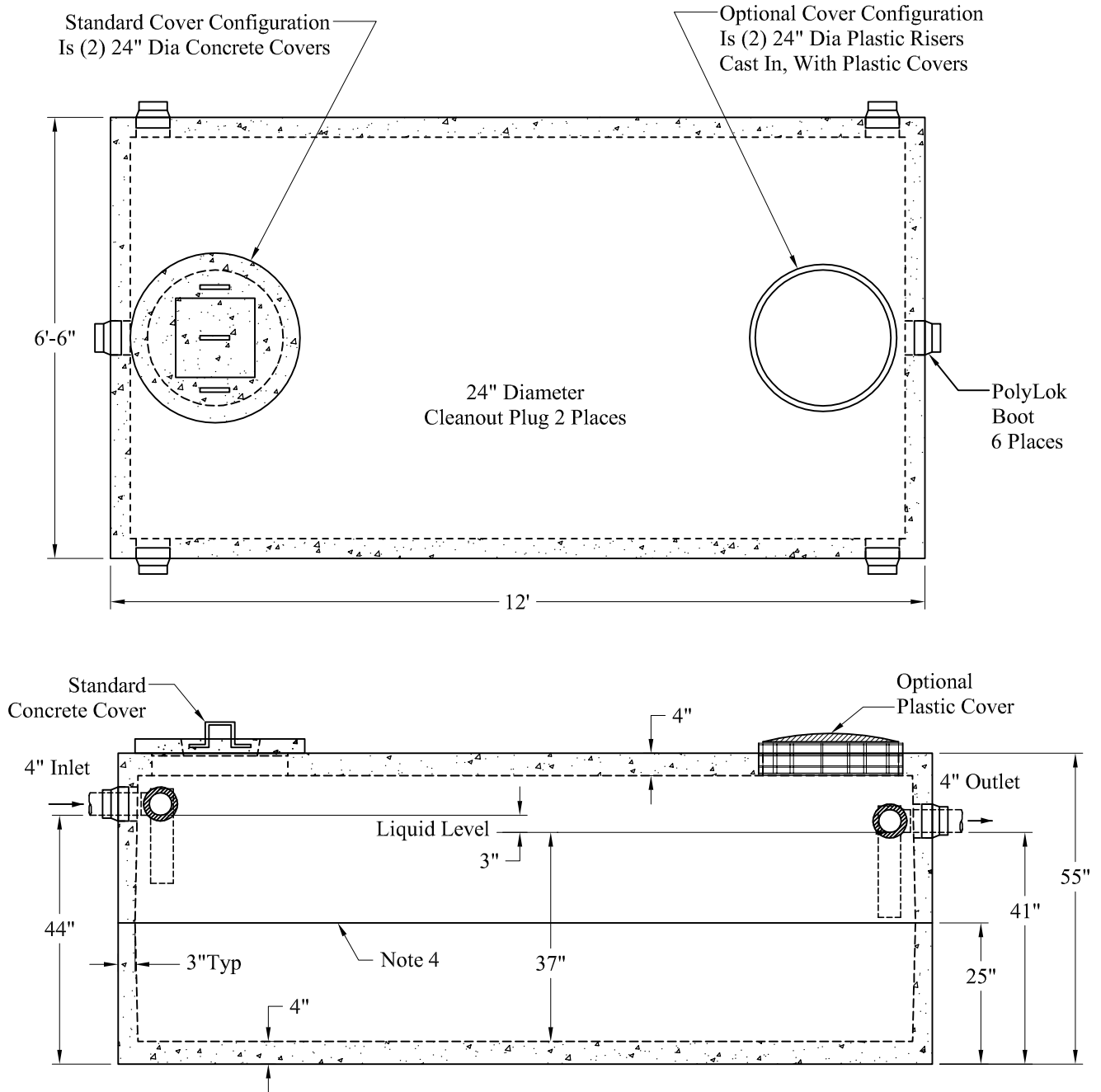

General Notes

1. Steel Reinforcement Conforms to Latest ASTM Specifications: ASTM-A615 Grade 60 Rebar
 2. Concrete: fc = 4,000 psi @ 28 Days Minimum
 3. Flexible Sleeves Used On All Pipe Openings
 4. Butyl Rubber Joint Sealant Provided
 5. Internal PVC Baffles Available
- Inlet: Shall Penetrate at Least 9" Below the Liquid Level, But Not Deeper Than the Outlet Baffle.
- Outlet: Shall Extend Below the Surface of the Liquid Equal to 40% of the Liquid Depth (15").
6. HD Tanks: 3' - 6' Cover Max, Non-Traffic

Est Weight:

Upper: 6,850 Lbs
 Lower: 6,625 Lbs
 Total: 13,475 Lbs

Phoenix
Precast
Products

1,500 Gallon
HD Septic Tank
(Ledge)

P/N: ST-1500LHD