

1-800-639-2199

Fax (603) 224-2927

Tanks\Standard\1,750Gal\1750 Gal HD Tank Top Seam

Phoenix Precast Products

Phoenix Precast Products

Standard Cover Configuration  
Is (2) 24" Dia Concrete Covers

Optional Cover Configuration  
Is (2) 24" Dia Plastic Risers  
Cast In, With Plastic Covers

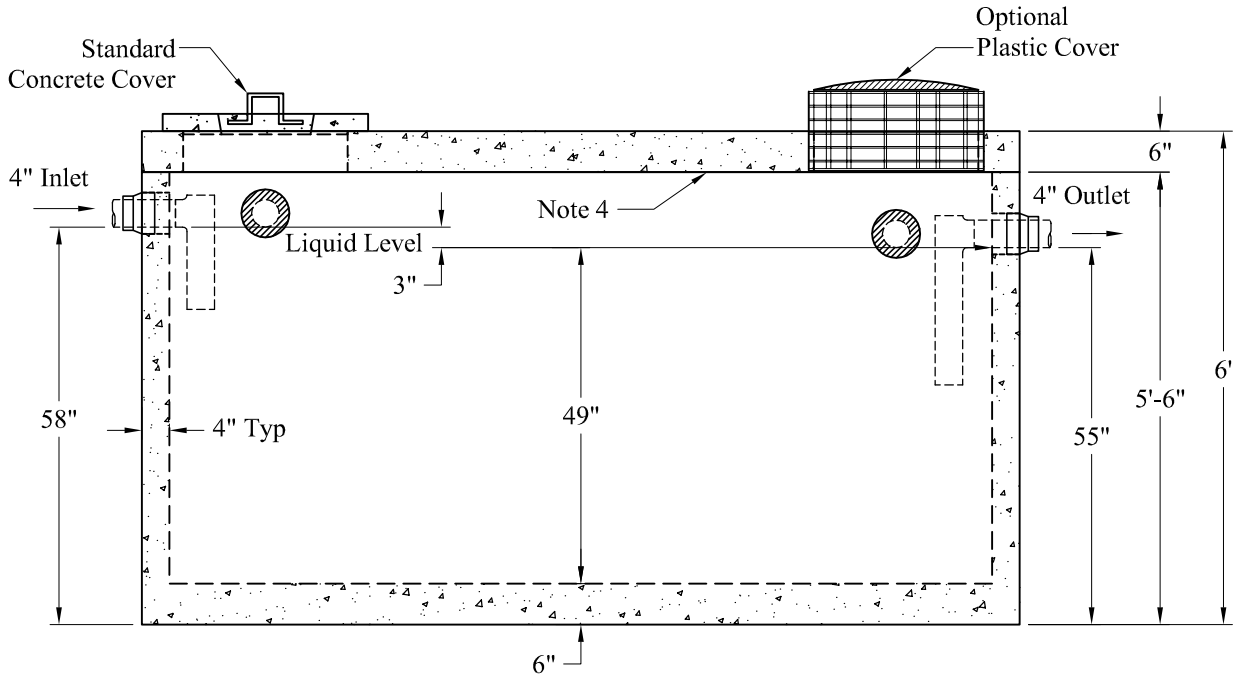
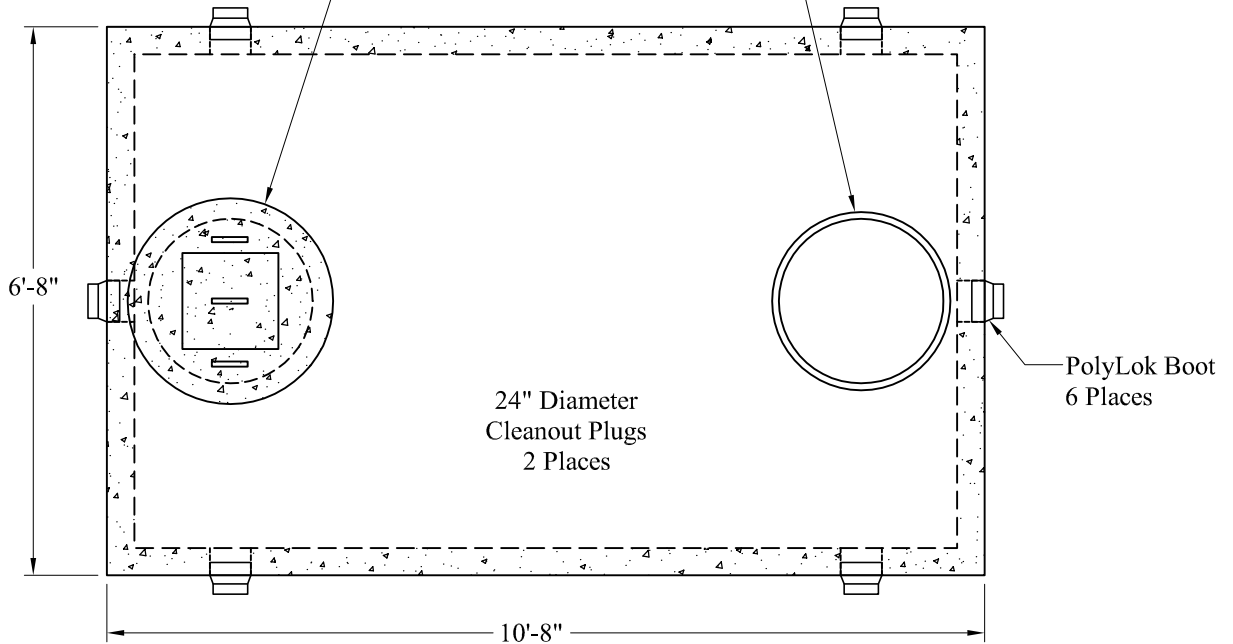

**General Notes**

1. Steel Reinforcement Conforms to Latest ASTM Specifications: ASTM-A615 Grade 60 Rebar
  2. Concrete:  $f_c = 4,000$  psi @ 28 Days Minimum
  3. Flexible Sleeves Used On All Pipe Openings
  4. Butyl Rubber Joint Sealant Provided
  5. Internal PVC Baffles Available
- Inlet: Shall Penetrate at Least 9" Below the Liquid Level, But Not Deeper Than the Outlet Baffle.
- Outlet: Shall Extend Below the Surface of the Liquid Equal to 40% of the Liquid Depth (20").
6. HD Tanks: 3' - 6' Cover Max, Non-Traffic

Weights:

Top Slab: 4,800 Lbs

Base: 13,450 Lbs

Total Weight: 18,250 Lbs

Phoenix  
Precast  
Products

1,750 Gallon  
Top Seam  
HD Septic Tank

P/N: ST-1750MHD