

1-800-639-2199

Fax (603) 224-2927

Tanks\Compartment2 Comp\1750 LD 1250-500 2-Comp Mid-Seam Tank (New Form)

Phoenix Precast Products

Phoenix Precast Products

Standard Cover Configuration  
Is (3) 24" Dia Concrete Covers

Optional Cover Configuration  
Is (3) 24" Dia Plastic Risers  
Cast In, With Plastic Covers

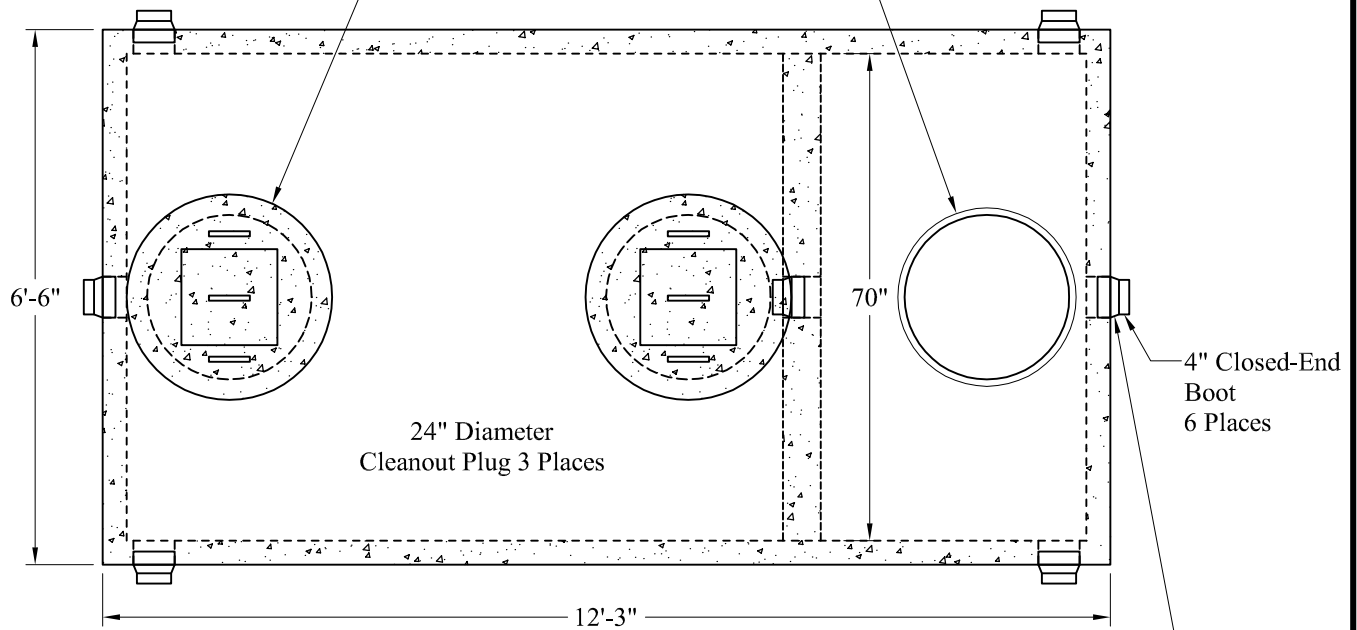

NOTE: A Pipe Bushing Will Be Required  
On All Boots with Pipes Less Than 4"

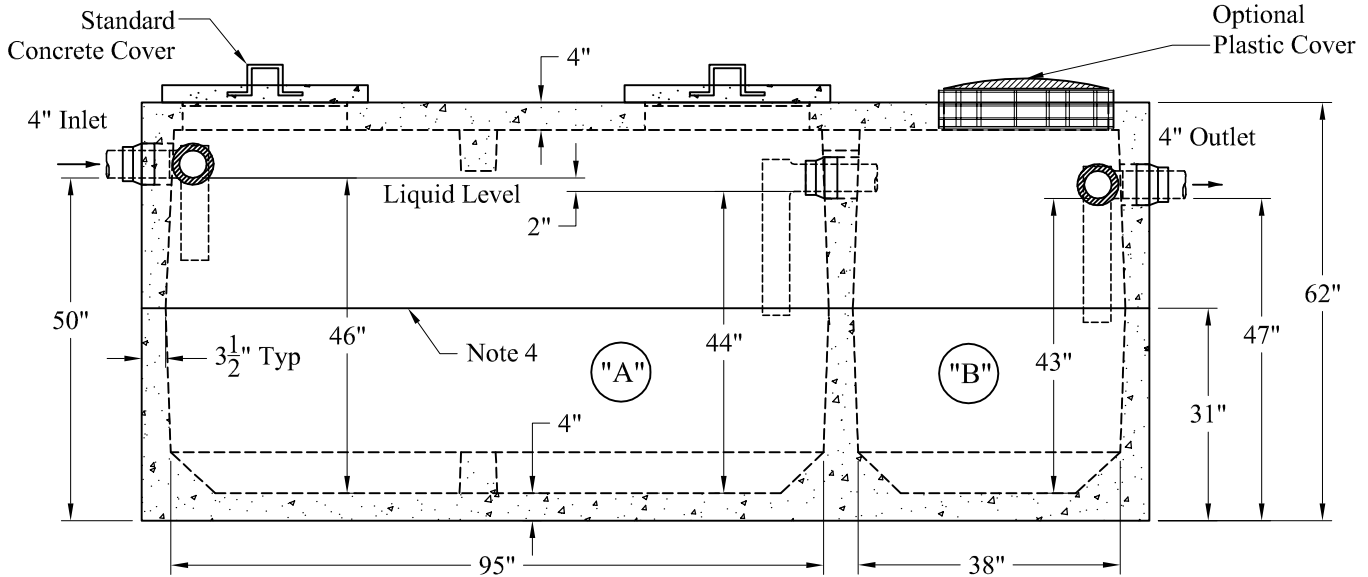

**General Notes**

1. Steel Reinforcement Conforms to Latest ASTM Specifications: ASTM-A615 Grade 60 Rebar
2. Concrete:  $f_c = 4,000$  psi @ 28 Days Minimum
3. Flexible Sleeves Used On All Pipe Openings
4. Butyl Rubber Joint Sealant Provided
5. Internal PVC Baffles Available
- Inlet: Shall Penetrate at Least 9" Below the Liquid Level, But Not Deeper Than the Outlet Baffle.
- Outlet: Shall Extend Below the Surface of the Liquid Equal to 40% of the Liquid Depth (17").
6. LD Tanks: 3' Cover Max, Non-Traffic

"A" Liquid Level = 345 Gals/VF (29 Gals/In)

"B" Liquid Level = 140 Gals/VF (12 Gals/In)

"A" = 1,266 Gals

"B" = 501 Gals

Total = 1,767 Gals

Est Weight:

Upper: 7,900 Lbs

Lower: 9,360 Lbs

Total = 17,260 Lbs

Phoenix  
Precast  
Products

1250/500 Gallon LD  
2 Compartment Tank

P/N: 1250/500LD