

Tanks/Compartment2_Comp/Small LD 2_Comp_1250_900 Tank

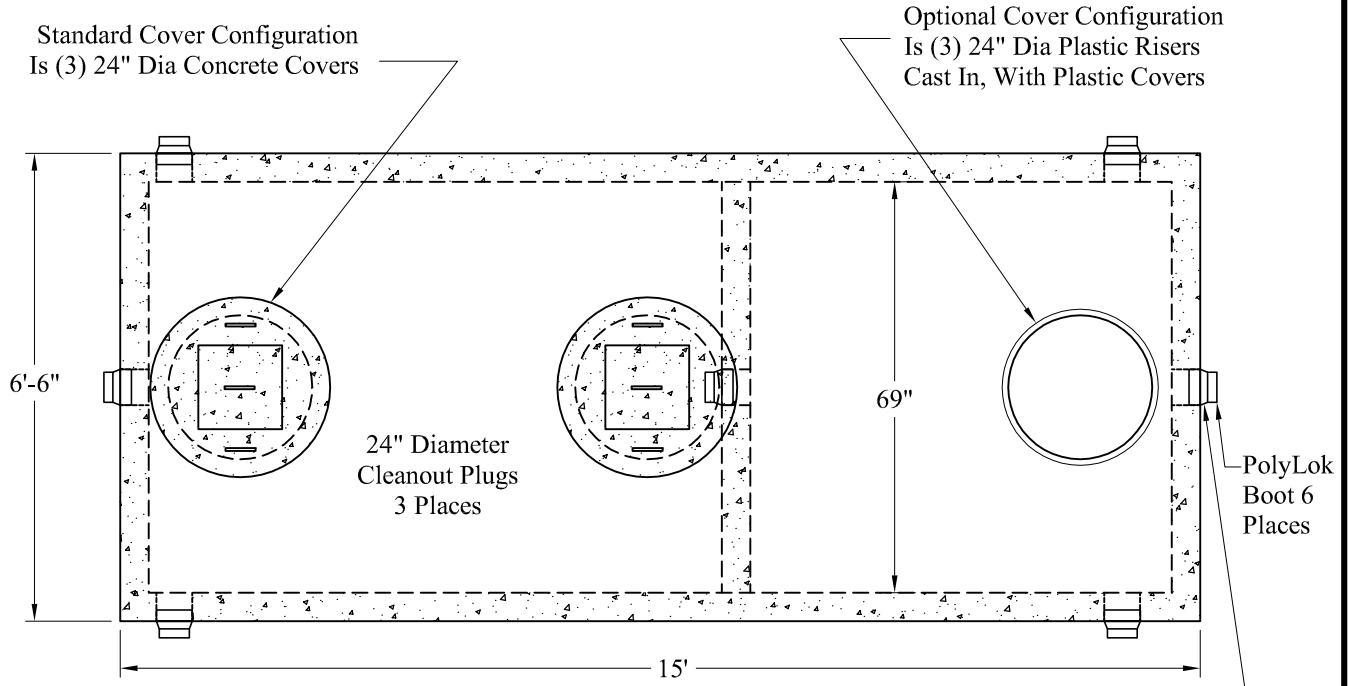

NOTE: A Pipe Bushing Will Be Required On All Boots with Pipes Less Than 4"

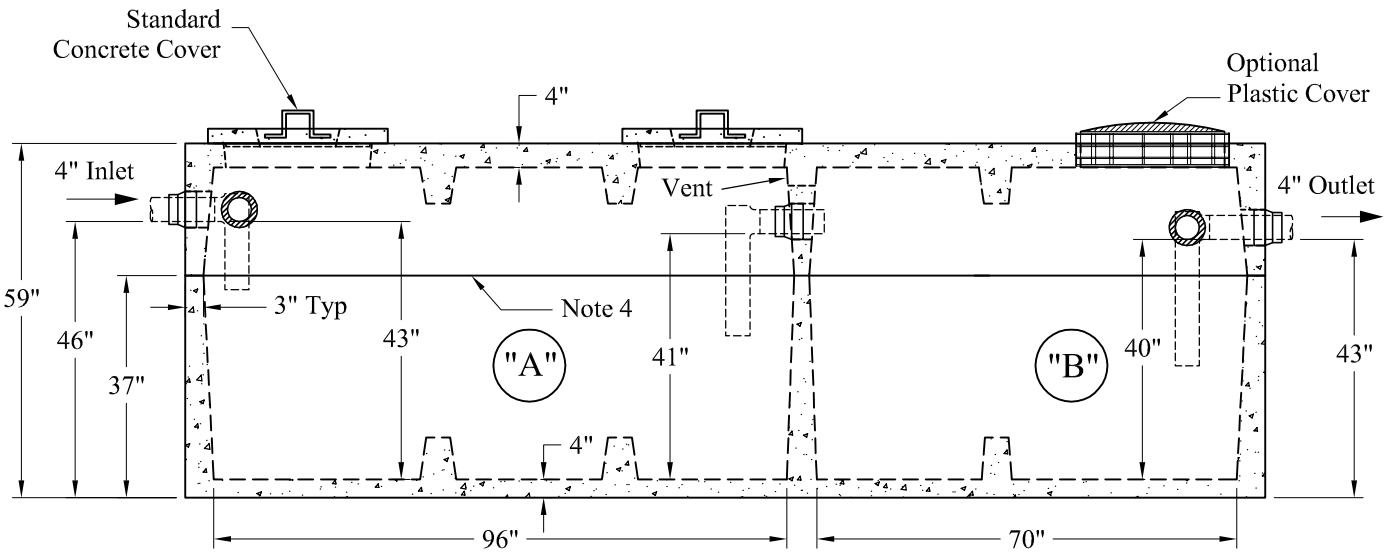

General Notes

1. Steel Reinforcement Conforms to Latest ASTM Specifications: ASTM-A615 Grade 60 Rebar
 2. Concrete: $f_c = 4,000$ psi @ 28 Days Minimum
 3. Flexible Sleeves Used On All Pipe Openings
 4. Butyl Rubber Joint Sealant Provided
 5. Internal PVC Baffles Available
- Inlet: Shall Penetrate at Least 9" Below the Liquid Level, But Not Deeper Than the Outlet Baffle.
- Outlet: Shall Extend Below the Surface of the Liquid Equal to 40% of the Liquid Depth (17").
6. LD Tanks: 3' Cover Max, Non-Traffic

"A" Liquid Level = 355 Gals/VF (30 Gals/In)	Est Weight:
"B" Liquid Level = 262 Gals/VF (22 Gals/In)	
"A" = 1,214 Gals	
"B" = 872 Gals	
Total = 2,086 Gals	Top: 9,440 Lbs
	Base: 11,790 Lbs
	Total: 21,230 Lbs

**Phoenix
Precast
Products** **1,250 / 900 Gallon LD
2 Compartment Tank**

P/N: ST1250/900LD

Phoenix Precast Products

Phoenix Precast Products