

1-800-639-2199

Fax (603) 224-2927

Tanks\Compartment2_Comp\Med LD 2_Comp_1400-1000 Tank

Standard Cover Configuration
Is (3) 24" Dia Concrete Covers

Optional Cover Configuration
Is (3) 24" Dia Plastic Risers
Cast In, With Plastic Covers

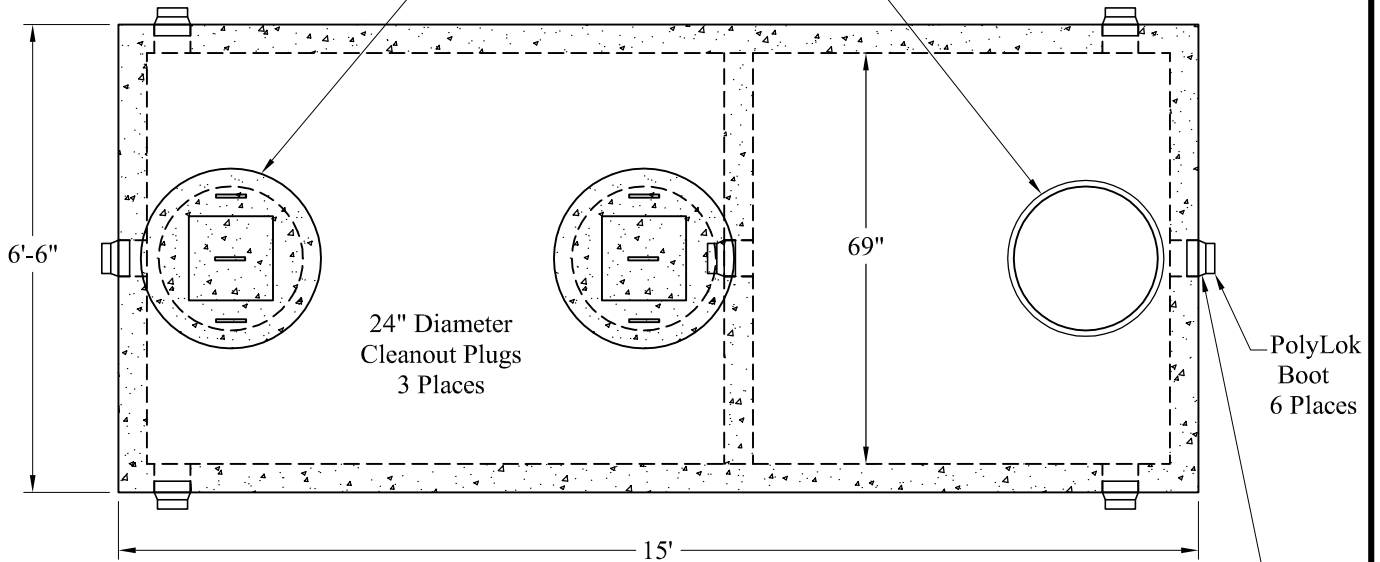

NOTE: A Pipe Bushing Will Be Required
On All Boots with Pipes Less Than 4"

Phoenix Precast Products

Phoenix Precast Products

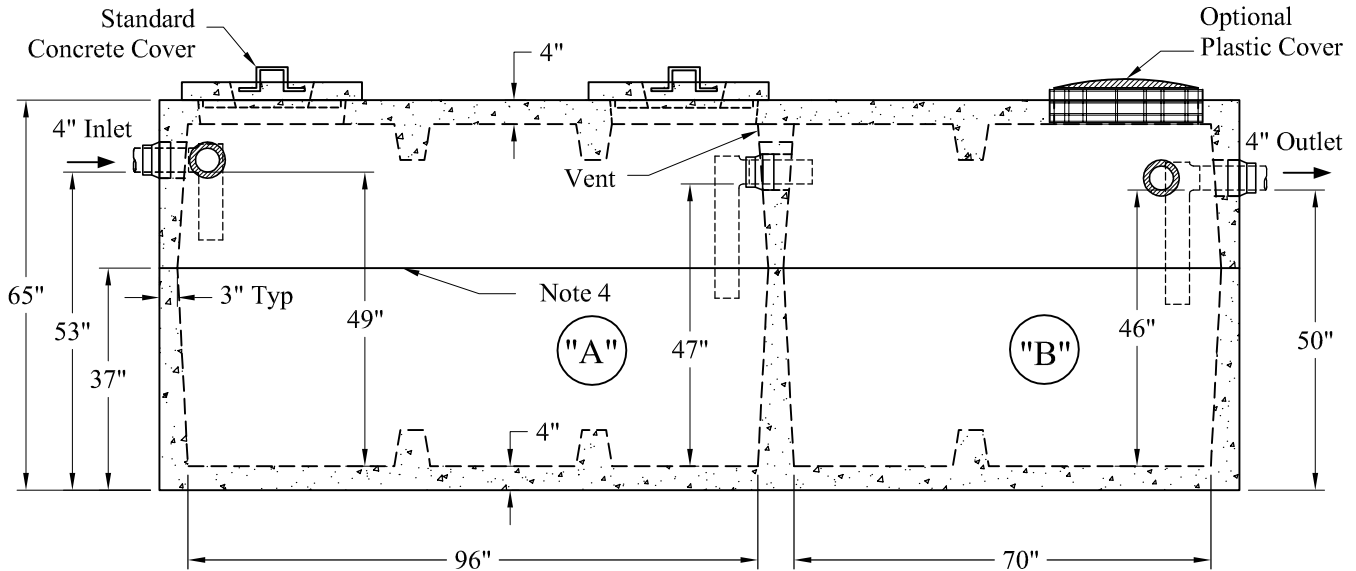

General Notes

1. Steel Reinforcement Conforms to Latest ASTM Specifications: ASTM-A615 Grade 60 Rebar
 2. Concrete: $f_c = 4,000$ psi @ 28 Days Minimum
 3. Flexible Sleeves Used On All Pipe Openings
 4. Butyl Rubber Joint Sealant Provided
 5. Internal PVC Baffles Available
- Inlet: Shall Penetrate at Least 9" Below the Liquid Level, But Not Deeper Than the Outlet Baffle.
 Outlet: Shall Extend Below the Surface of the Liquid Equal to 40% of the Liquid Depth (19").
6. LD Tanks: 3' Cover Max, Non-Traffic

"A" Liquid Level = 355 Gals/VF (30 Gals/In)

"B" Liquid Level = 262 Gals/VF (22 Gals/In)

"A" = 1,392 Gals

"B" = 1,003 Gals

Total = 2,395 Gals

Est Weight:

Upper: 9,800 Lbs

Lower: 11,790 Lbs

Total: 21,590 Lbs

Phoenix
Precast
Products

1400/1000 Gallon LD
2 Compartment Tank

P/N: ST-1400/1000LD