

1-800-639-2199

Fax (603) 224-2927

Standard Cover Configuration  
Is (3) 24" Dia Concrete Covers

Optional Cover Configuration  
Is (3) 24" Dia Plastic Risers  
Cast In, With Plastic Covers

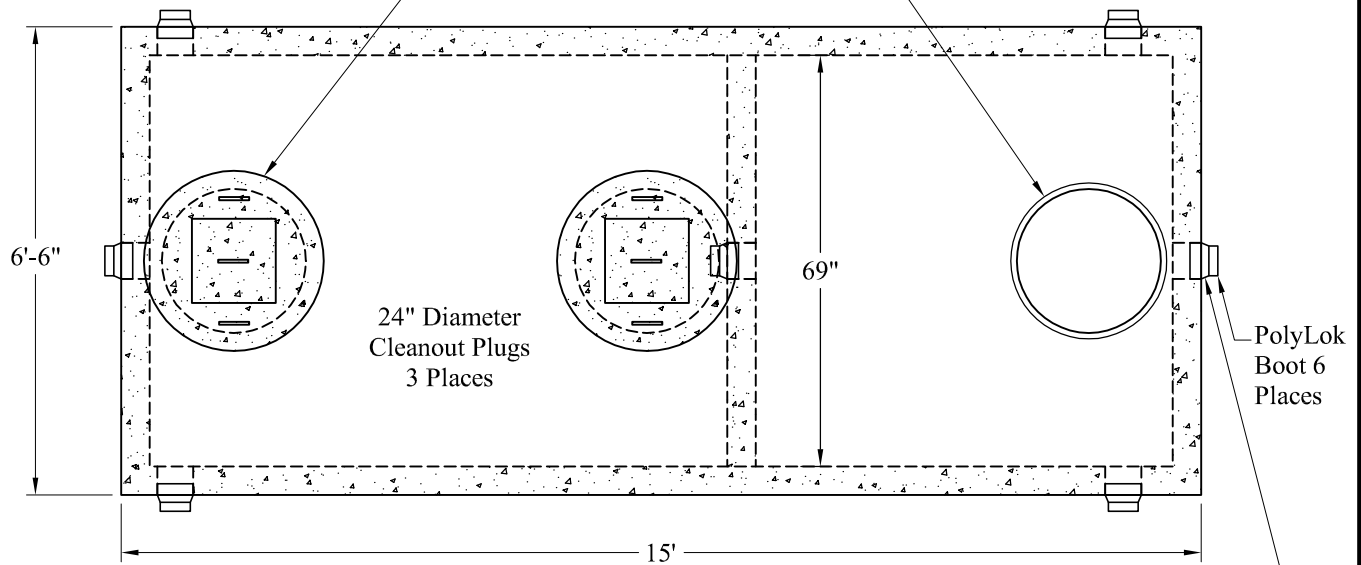

NOTE: A Pipe Bushing Will Be Required  
On All Boots with Pipes Less Than 4"

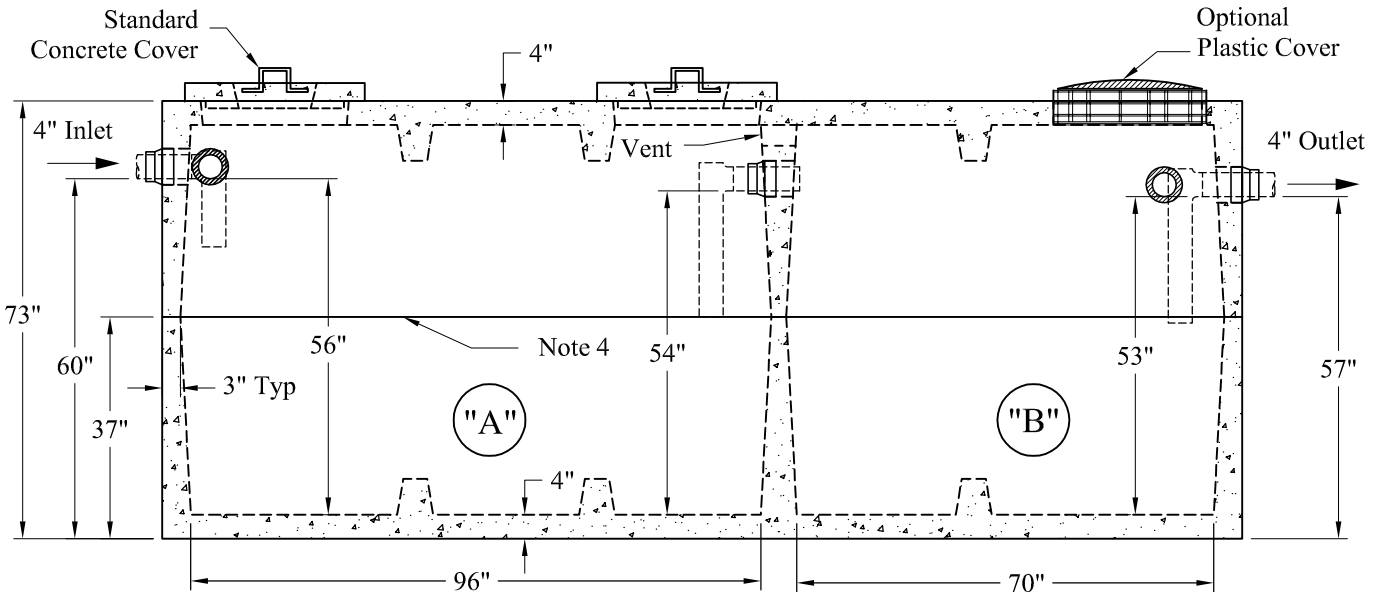

**General Notes**

1. Steel Reinforcement Conforms to Latest ASTM Specifications: ASTM-A615 Grade 60 Rebar
  2. Concrete:  $f_c = 4,000$  psi @ 28 Days Minimum
  3. Flexible Sleeves Used On All Pipe Openings
  4. Butyl Rubber Joint Sealant Provided
  5. Internal PVC Baffles Available
- Inlet:** Shall Penetrate at Least 9" Below the Liquid Level, But Not Deeper Than the Outlet Baffle.
- Outlet:** Shall Extend Below the Surface of the Liquid Equal to 40% of the Liquid Depth (21").
6. LD Tanks: 3' Cover Max, Non-Traffic

"A" Liquid Level = 355 Gals/VF (30 Gals/In)

"B" Liquid Level = 262 Gals/VF (22 Gals/In)

"A" = 1,598 Gals

"B" = 1,158 Gals

Total = 2,756 Gals

Est Weight:

Top: 11,780 Lbs

Base: 11,790 Lbs

Total: 23,570 Lbs

Phoenix  
Precast  
Products

1600/1000 Gallon LD  
2 Compartment Tank

P/N: ST-1600/1000LD