

1-800-639-2199

Fax (603) 224-2927

Tanks\Compartment2\_Comp\3000\_HD\_2000-1000\_2 Comp Tank Sales

Standard Cover Configuration  
Is (3) 24" Dia Concrete Covers

Optional Cover Configuration  
Is (3) 24" Dia Plastic Risers  
Cast In, With Plastic Covers

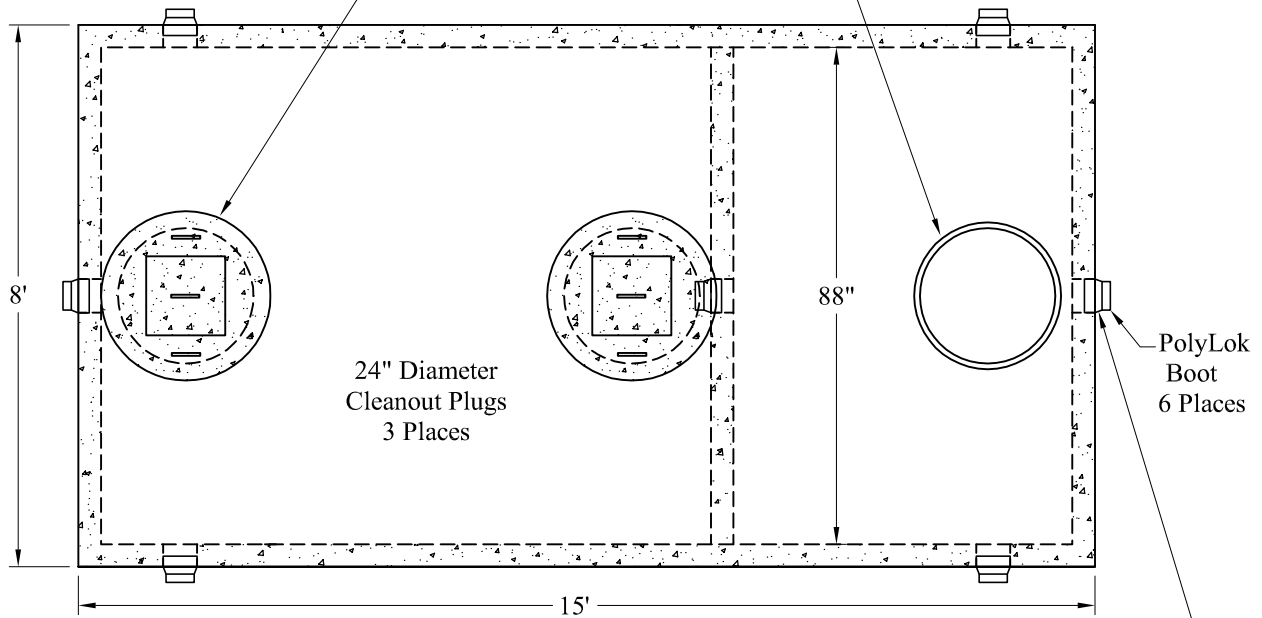

NOTE: A Pipe Bushing Will Be Required  
On All Boots with Pipes Less Than 4"

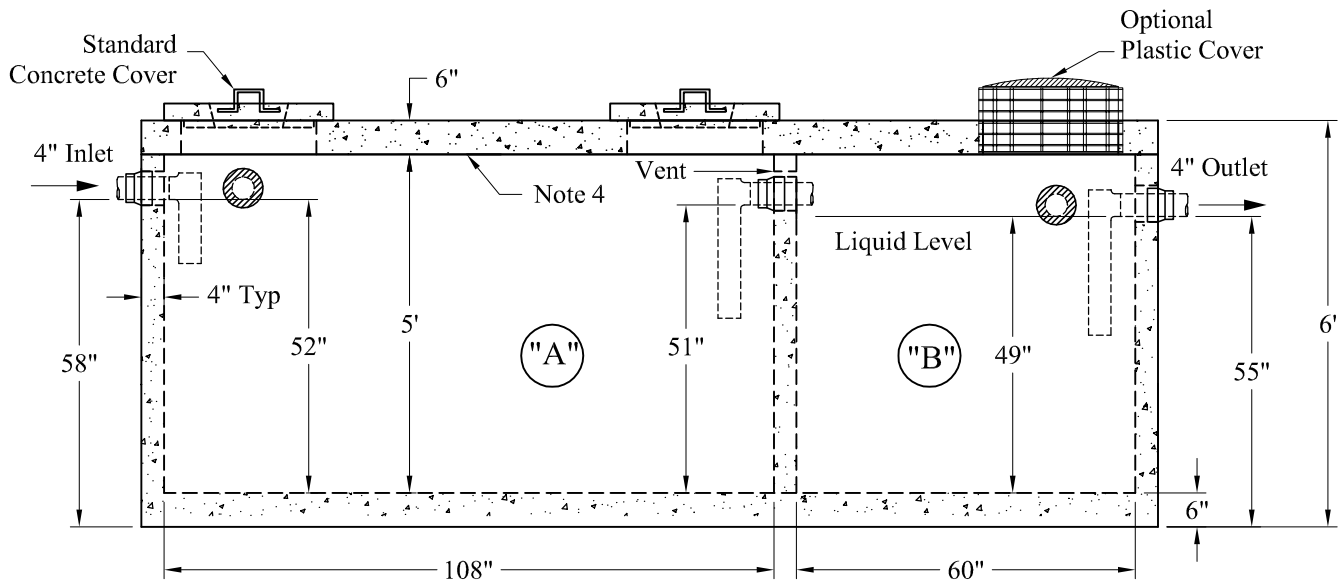

**General Notes**

1. Steel Reinforcement Conforms to Latest ASTM Specifications: ASTM-A615 Grade 60 Rebar
  2. Concrete:  $f_c = 4,000$  psi @ 28 Days Minimum
  3. Flexible Sleeves Used On All Pipe Openings
  4. Butyl Rubber Joint Sealant Provided
  5. Internal PVC Baffles Available
- Inlet: Shall Penetrate at Least 9" Below the Liquid Level, But Not Deeper Than the Outlet Baffle.
- Outlet: Shall Extend Below the Surface of the Liquid Equal to 40% of the Liquid Depth (20").
6. HD Tanks: 3' -6' Cover Max, Non-Traffic

"A" Liquid Level = 495 Gals/VF(41 Gals/In)

"B" Liquid Level = 275 Gals/VF(23 Gals/In)

"A" = 2,103 Gallons

"B" = 1,122 Gallons

3,225 Gallons

Est. Weights:

Top Slab - 8,200 Lbs

Base - 21,600 Lbs

Total: 29,800 Lbs

Phoenix  
Precast  
Products

2,000/1,000 Gallon  
HD 2 Compartment  
Top Seam Tank

P/N: ST-2000/1000HD