

Ø3/4" Hole

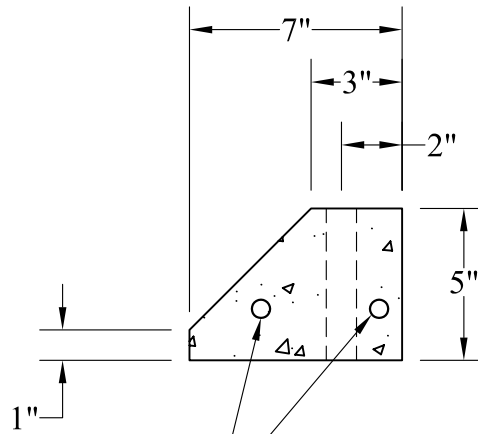
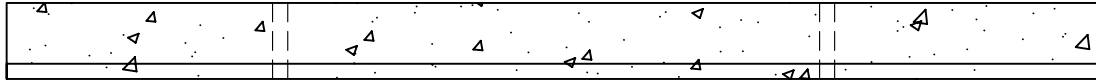

#3 Rebar 2 Places

General Notes

1. Steel Reinforcement Conforms to Latest ASTM Specifications: ASTM-A615 Grade 60 Rebar
2. Concrete: $f_c = 4,000$ psi @ 28 Days Minimum
3. Locating Pins (Optional) = #4 Rebar x 18" Long
4. Estimated Weight: 165 Lbs

Phoenix
Precast
Products

Car Parking
Bumper