

Concrete:  $f_c = 4,500$  psi @ 28 Days  
Steel Reinforcement: ASTM A615, Grade 60, 1" Min Cover  
Minimum Design Load: AASHTO HS20-44

Est Weight: 1,750 Lbs

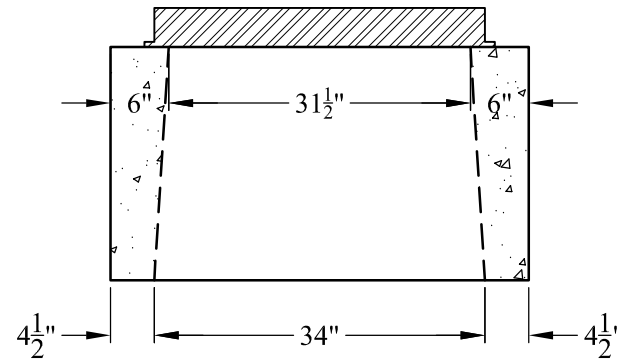
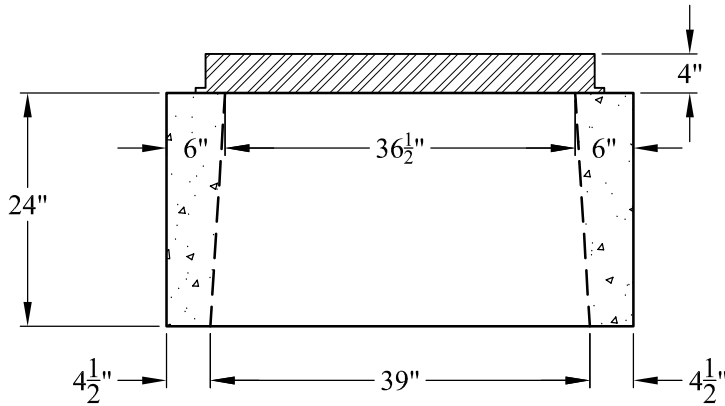
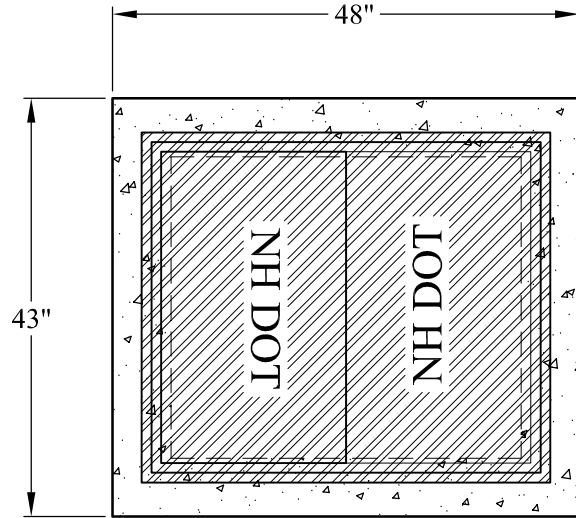

Phoenix Precast Products

Phoenix Precast Products

Customer:	Job No.	Date 09/23/10	Drawn By: EWS	Phoenix Precast Products	3' x 31" x 2' NH DOT Pull Box
Location:	Custom No.	Rev: 2	App'd:		