

1-800-639-2199

Fax (603) 224-2927

Meter Manholes 4 x 11 x 5 Ft Meter MH (v)

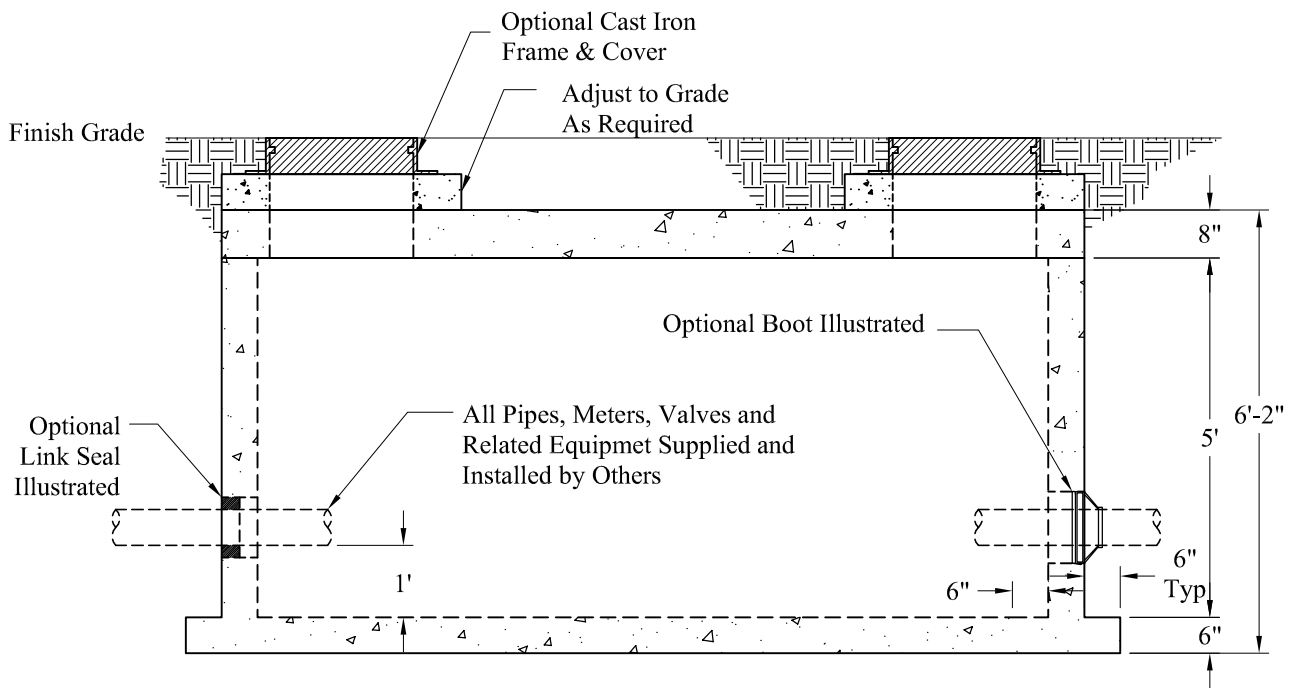
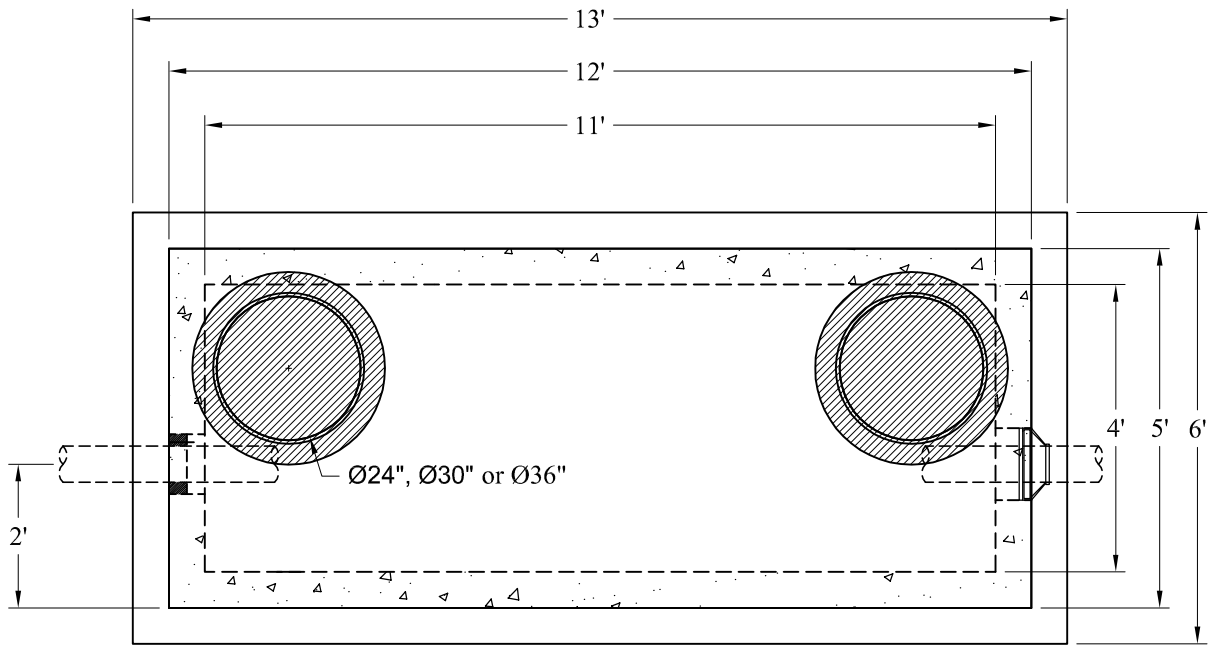

General Notes

1. Concrete: $f_c = 5,000$ psi @ 28 Days Minimum, Type III Cement
2. Steel Reinforcement Conforms to Latest ASTM Specification: ASTM A-615, Grade 60 Black Deformed Bars
3. Butyl Rubber Joint Sealant Provided Conforms to ASTM C-990 And Federal Spec SS-S-210A
4. HS-20 Design Loading Conforms to Latest Specifications ASTM C478, AASHTO M199 Precast Reinforced Concrete Manhole Sections
5. Design Specification: per Latest ASTM C-857 & C858

Est Weights:

Top Slab:	5,900 Lbs
Base:	17,650 Lbs
Total:	23,550 Lbs

Phoenix
Precast
Products

4' x 11' x 5'
Meter Manhole

Phoenix Precast Products

Phoenix Precast Products