

1-800-639-2199

Fax (603) 224-2927

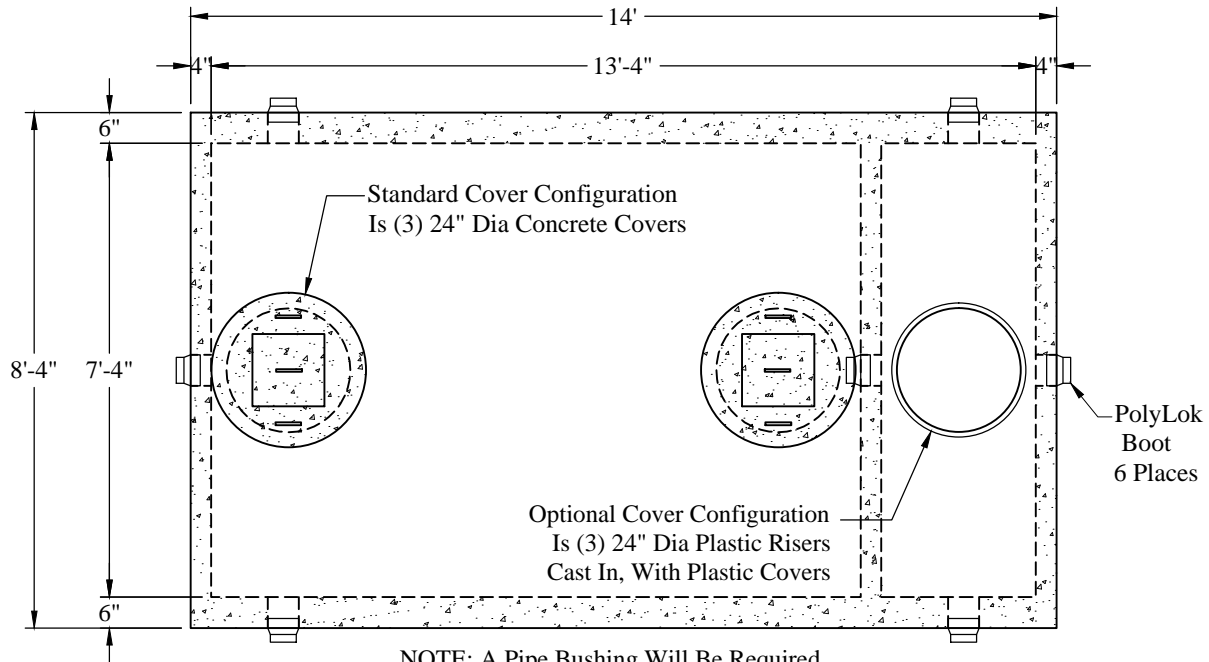

NOTE: A Pipe Bushing Will Be Required On All Boots with Pipes Less Than 4"

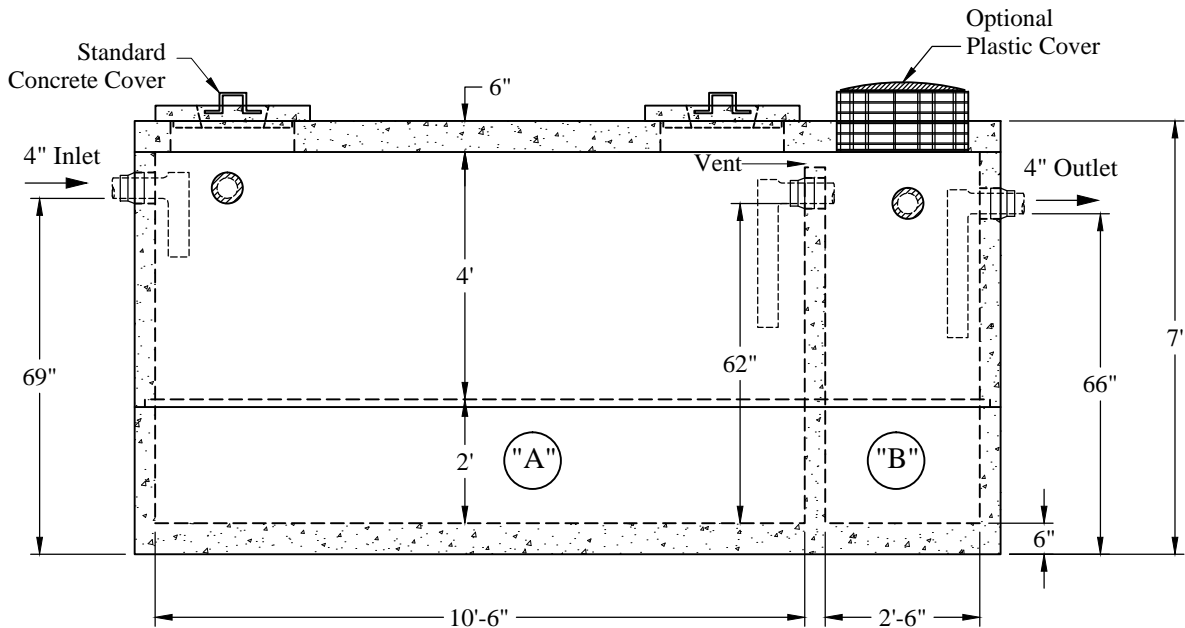

General Notes:

1. Concrete: $f_c = 4,000$ psi @ 28 Days Minimum
2. Steel Reinforcement Conforms to Latest ASTM Specifications: ASTM-A615 Grade 60 Rebar
3. Flexible Sleeves Used On All Pipe Openings
4. Butyl Rubber Joint Sealant Provided
5. Internal PVC Baffles Available
- Inlet: Shall Penetrate at Least 9" Below the Liquid Level, But Not Deeper Than the Outlet Baffle.
- Outlet: Shall Extend Below the Surface of the Liquid Equal to 40% of the Liquid Depth (24").
6. HD Tanks: 3' -6' Cover Max, Non-Traffic

"A" Liquid Level = 577 Gals/VF (48 Gals/In)
 "B" Liquid Level = 137 Gals/VF (11 Gals/In)
 "A" = 2,984 Gallons
 "B" = 687 Gallons
 3,671 Gallons

Est. Weights:

Top Slab:	7,900 Lbs
4' Riser:	12,600 Lbs
Base:	15,000 Lbs
Total:	35,500 Lbs

Phoenix
 Precast
 Products

3,000/650 Gallon
 HD 2 Compartment
 Top Seam Tank

P/N: ST-3000/650HD

77 Regional Drive

Concord, NH 03301

Phoenix Precast Products

Phoenix Precast Products