

Phoenix Precast Products

Phoenix Precast Products

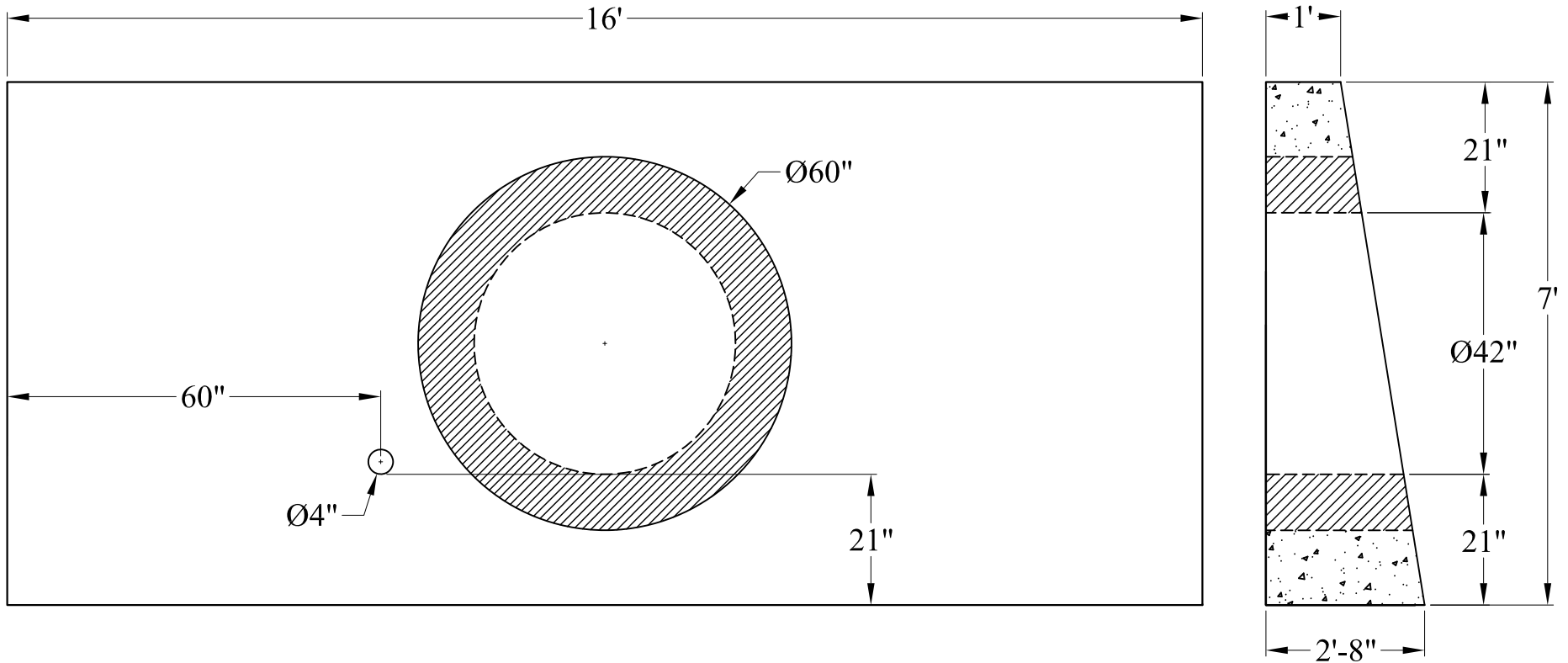

General Notes

1. Steel Reinforcement Conforms to Latest ASTM Specification: ASTM A-615
2. Concrete:  $f_c = 5,000$  PSI @ 28 Days Minimum
3. Est. Weight: 26,150 Lbs.

Phoenix  
Precast  
Products

N.H. DOT  
42" RCP Headwall

P/N: HWSDOT-42