

Recessed Opening Must Accept 1/2" Shackle

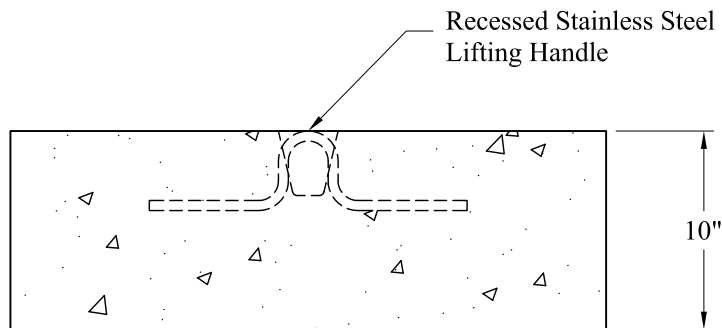

**General Notes**

1. Concrete:  $f_c = 4,000$  psi @ 28 Days Minimum
2. Fiber Reinforcement
3. Steel Reinforcement: ASTM A615 Grade 60
4. 304 Stainless Steel Lifting Handle
5. Est Weight: 600 Lbs

Phoenix  
Precast  
Products

600 Lb  
Mooring Weight

P/N: MW600

Concord, NH 03301

77 Regional Drive