

End View

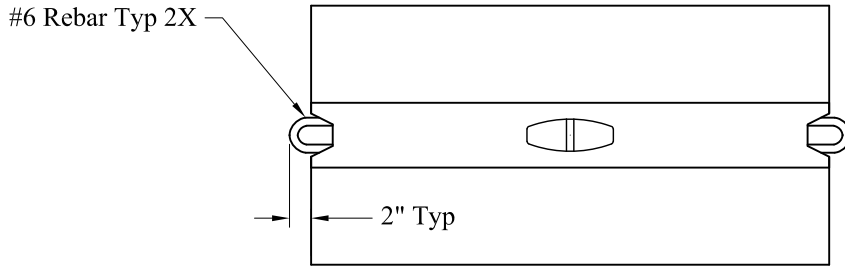

Plan View

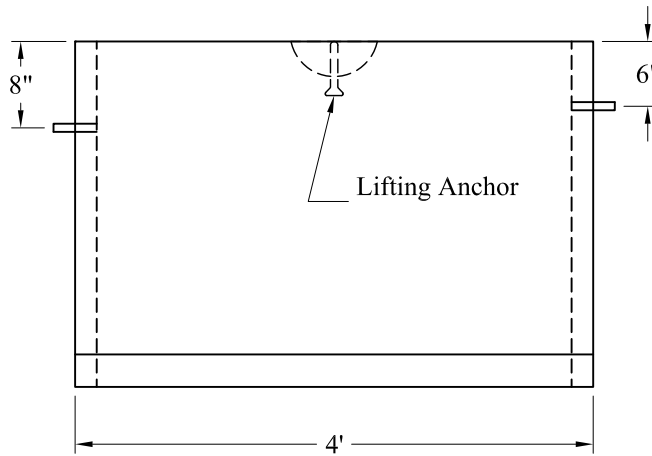

Elevation View

Est Weight: 1,600 Lbs

General Notes

- 1. Concrete: f'c = 4,000 psi @ 28 Days Minimum.
- 2. Reinforcing Steel Conforms to Latest ASTM Specification: ASTM-A615 Grade 60 Black Deformed Bars

Phoenix
Precast
Products

4' Portable
Concrete Barrier

P/N: TCB-4