

1-800-639-2199

Fax (603) 224-2927

Tanks/Compartment2 Comp/2650-500 HD 2 Comp/Top Seam Pump Tank Sales

Standard Cover Configuration  
Is (3) 24" Dia Concrete Covers

Optional Cover Configuration  
Is (3) 24" Dia Plastic Risers  
Cast In, With Plastic Covers

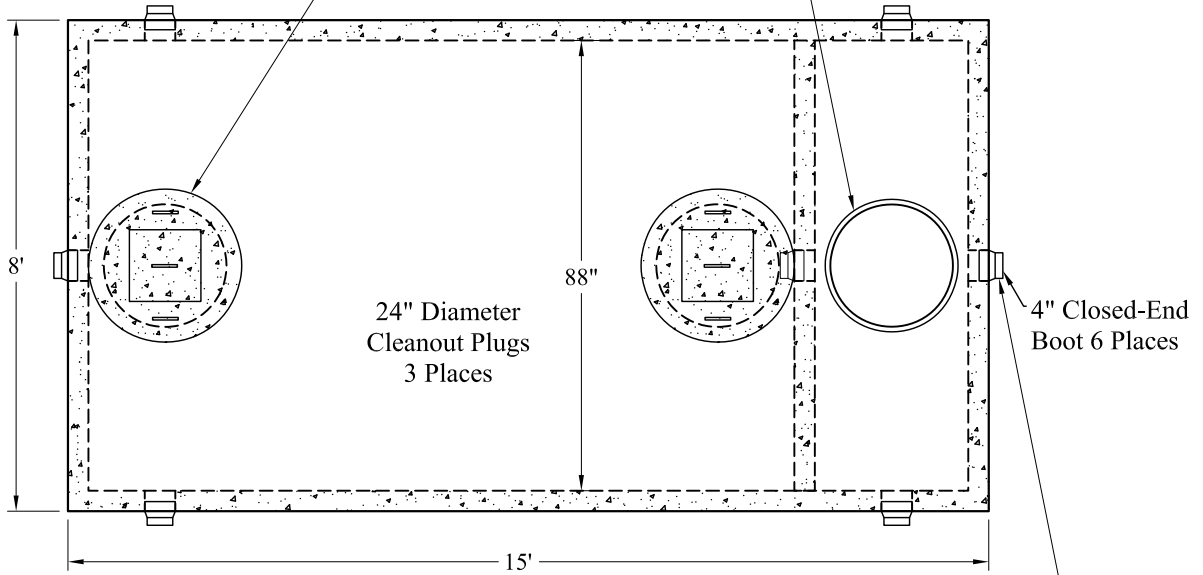

NOTE: A Pipe Bushing Will Be Required  
On All Boots with Pipes Less Than 4"

Standard  
Concrete Cover

Optional  
Plastic Cover

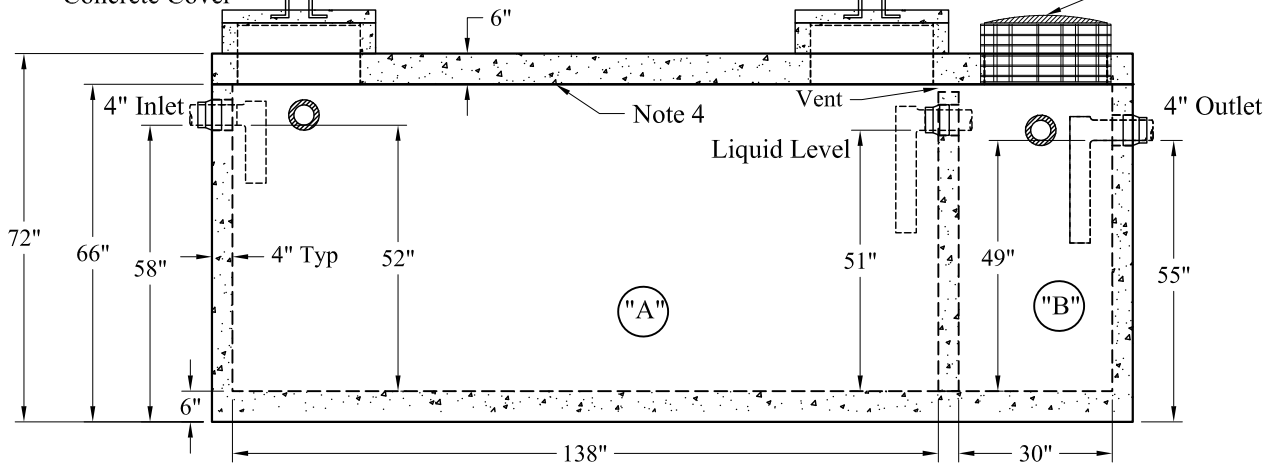

**General Notes**

1. Steel Reinforcement Conforms to Latest ASTM Specifications: ASTM-A615 Grade 60 Rebar
  2. Concrete:  $f_c = 4,000$  psi @ 28 Days Minimum
  3. Flexible Sleeves Used On All Pipe Openings
  4. Butyl Rubber Joint Sealant Provided
  5. Internal PVC Baffles Available
- Inlet:** Shall Penetrate at Least 9" Below the Liquid Level, But Not Deeper Than the Outlet Baffle.
- Outlet:** Shall Extend Below the Surface of the Liquid Equal to 40% of the Liquid Depth (20").
6. HD Tanks: 3' -6' Cover Max, Non-Traffic

"A" Liquid Level = 632 Gals/VF (53 Gals/In)  
 "B" Liquid Level = 137 Gals/VF (11 Gals/In)  
 "A" = 2,688 Gals  
 "B" = 561 Gals  
 Total = 3,349 Gals

Est Weights:  
 Top Slab: 8,200 Lbs  
 Base: 21,600 Lbs  
 Total: 29,800 Lbs

Phoenix  
Precast  
Products

2,650/500 Gallon  
HD 2 Compartment  
Top Seam Tank

P/N: ST-2650/500MHD