

NOTE: A Pipe Bushing Will Be Required  
On All Boots with Pipes Less Than 4"

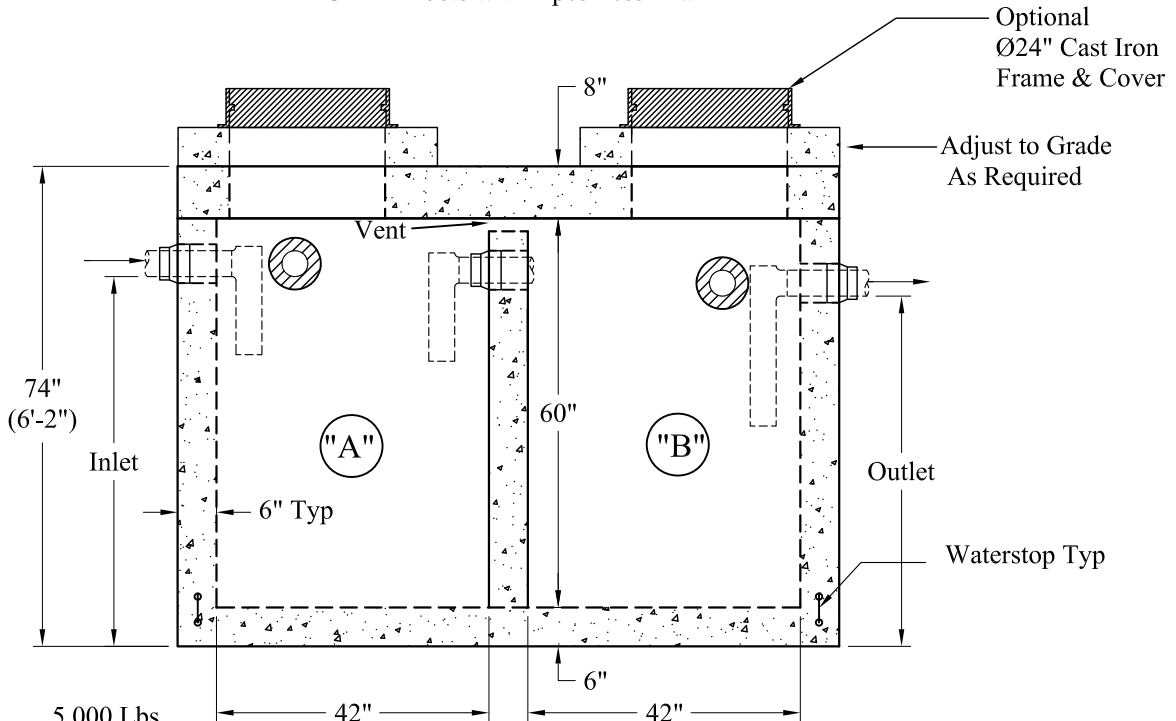

Weights:  
 Top Slab - 5,000 Lbs  
 Base - 14,850 Lbs  
 Total Weight: 19,850 Lbs

"A" Liquid Levels: = 131 Gals/VF(11Gals/In)    4" PVC Inverts:  
 "B" Liquid Levels: = 131 Gals/VF(11Gals/In)    Inlet-57"  
 4": "A"= 546 Gallons    Outlet-54"  
       "B" = 524 Gallons  
 6": "A"= 534 Gallons    6" PVC Inverts:  
       "B" = 513 Gallons    Inlet-56"  
                                   Outlet-53"

General Notes:

1. Steel Reinforcement Conforms to Latest ASTM Specifications: ASTM-A615 Grade 60 Rebar
  2. Concrete: fc = 5,000 psi @ 28 Days Minimum
  3. Flexible Sleeves Provided On All Pipe Connections
  4. Butyl Rubber Joint Sealant Provided
  5. Internal PVC Baffles Available Upon Request
- Inlet:** Shall Penetrate at Least 9" Below the Liquid Level, But Not Deeper Than the Outlet Baffle.  
**Outlet:** Shall Extend Below the Surface of the Liquid Equal to 40% of the Liquid Depth (19").
6. Design Loading: AASHTO-HS20-44, ASTM C-890-06
  7. Design Specified As: ASTM C-1227-08, ASTM C-913-08
  8. Other Inlet/Outlet Pipe Sizes Available

Phoenix  
 Precast  
 Products

500 / 500  
 2 Compartment  
 H-20 Tank

P/N: ST-500/500H20