

Pipe Chart		
Pipe	Pipe OD	Connection
V		
E		
I		
F		
D		
B		

Elevation Chart	
Description	Elevation
R	Rim
G	Finish Grade
V	Vent
E	Electric Connection(s)
I	Inlet
F	Force Main Outlet
D	Drain Back from Valve Vault
B	Inside Bottom Floor
C	Outside Bottom of Concrete

- 1.) Steel Reinforcement Conforms To Latest ASTM Specifications:
ASTM A-615 Grade 60 Black Deformed Bars
- 2.) Concrete: $f_c = 5,000$ PSI @ 28 Days Minimum, Type III Cement
- 3.) Butyl Rubber Joint Sealant Conforms to ASTM C-990 and Federal Spec SS-S-210A.
- 4.) Flexible Connection Provided For All Pipe Connections.
- 5.) All Pumps, Mounting Hardware, and Related Ancillary Equipment Provided by Others.
- 6.) Liquid Capacity = 600 Gallons/Vertical Foot (50 Gallons/Inch)
- 7.) AASHTO-HS20-44 Design Loading Conforms to Latest Specifications ASTM C 890 & C 913
- 8.) Hatch to Drain Into Wet Well Unless Otherwise Noted
- 9.) Bouyancy Calculations Provided With Shop Drawing Submittal

- Options:
- LinkSeal Pipe Connections
 - LinkSeal Electrical Connections
 - Exterior Damp Proofing/Water Proofing
 - Interior Coatings
 - Interior Fillet
 - Exterior Joint Wrap
 - Safety Net, Safety Grate
 - Winch Socket

- Est Weights:
- Top Slab: 15,800 Lbs
 - Risers: 4,400 Lbs/VF
 - 1' x 1' Fillet: 2,960 Lbs
 - Ext Base Slab: 15,100 Lbs

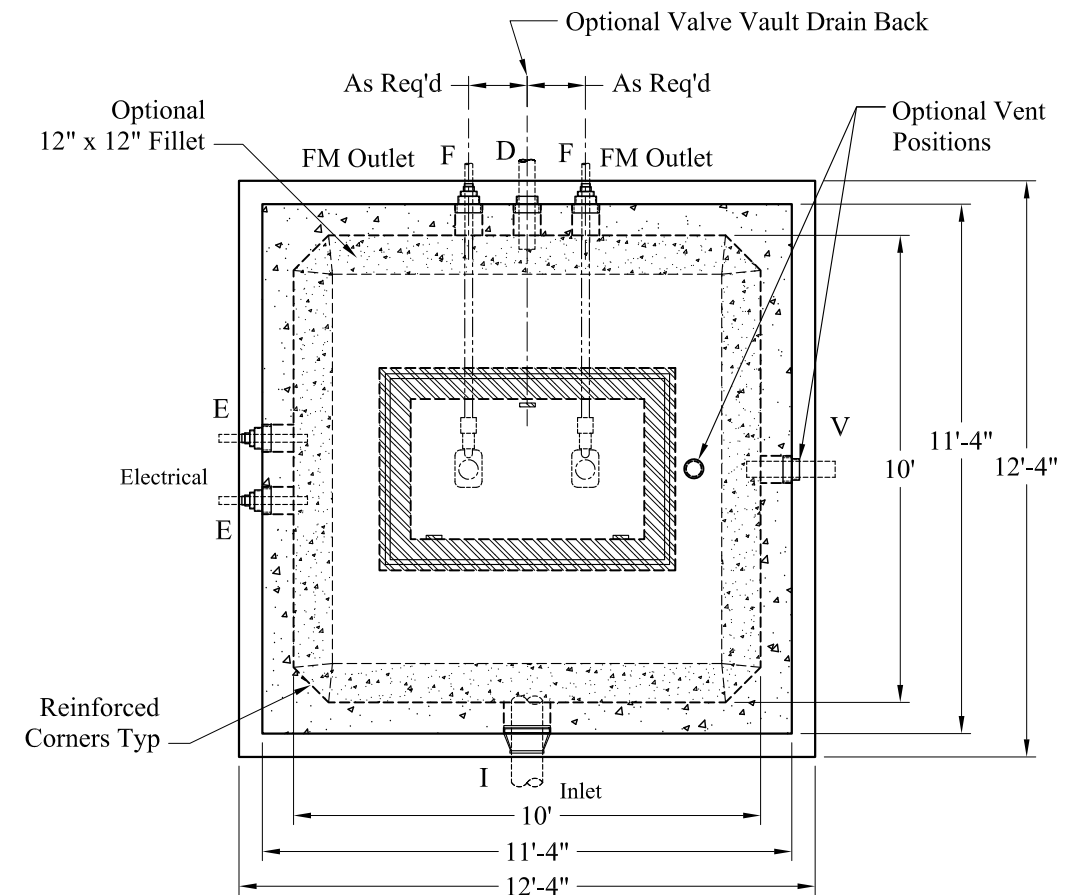
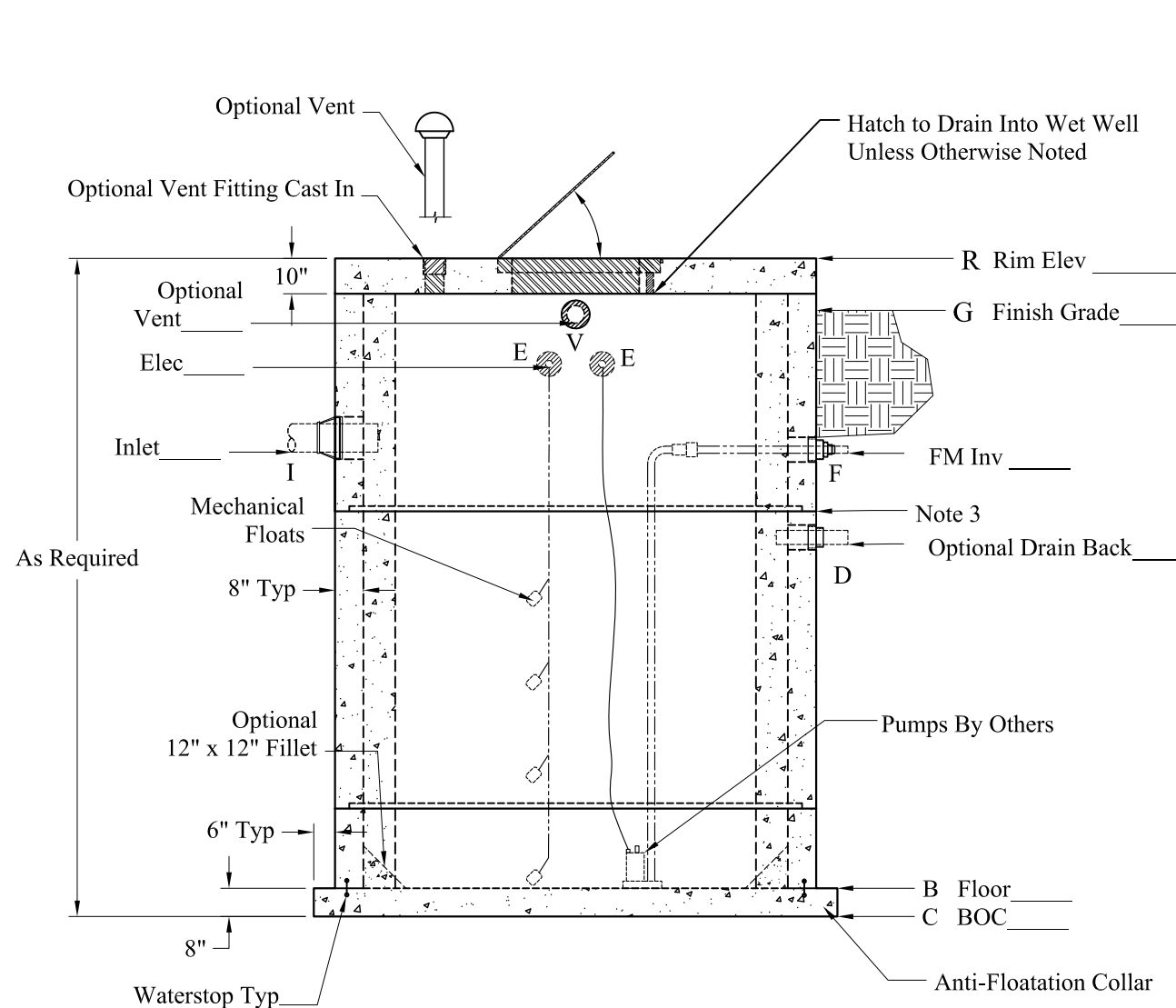

Phoenix Precast Products	10' x 10' Pump Station Wet Well Extended Base
	P/N: Custom As Required