

Phoenix Precast Products

Phoenix Precast Products

Pipe Chart		
Pipe	Pipe OD	Connection
E		
I		
F		
D		
B		

Elevation Chart		
Description	Elevation	
R	Rim	
G	Finish Grade	
E	Electric Connection(s)	
I	Inlet	
F	Force Main Outlet	
D	Drain Back To Wet Well	
B	Inside Bottom Floor	
C	Outside Bottom of Concrete	

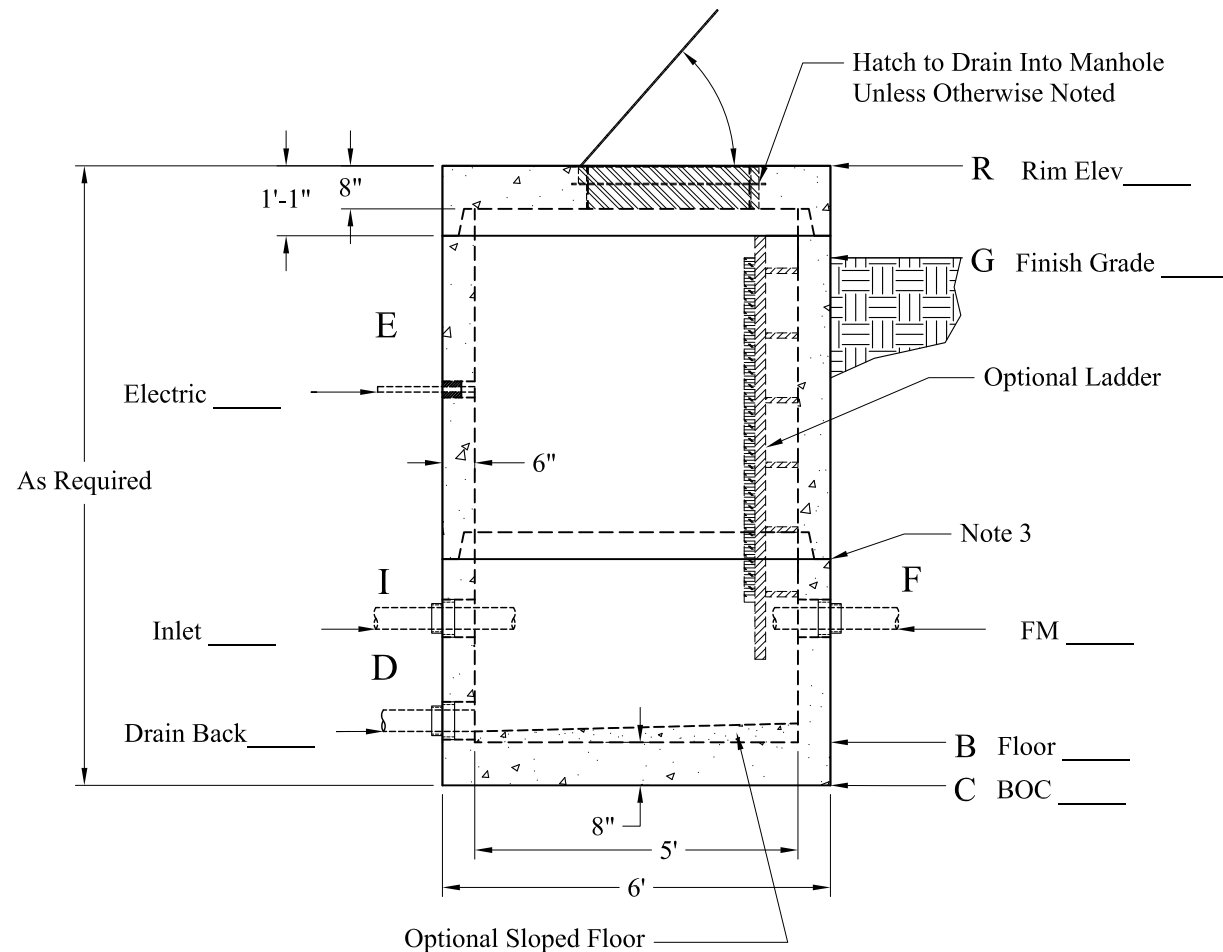

- Steel Reinforcement Conforms To Latest ASTM Specifications:
 ASTM A-615 Grade 60 Black Deformed Bars
 ASTM A-185 Welded Wire Fabric
- Concrete: $f_c = 5,000$ PSI @ 28 Days Minimum, Type III Cement
- Butyl Rubber Joint Sealant Conforms to ASTM C-990 and Federal Spec SS-S-210A
- Flexible Connection Provided For All Pipe Connections.
- All Valves, Mounting Hardware, and Related Ancillary Equipment Provided by Others.
- HS-20 Design Loading Conforms to Latest Specifications ASTM C478, AASHTO M199 Precast Reinforced Concrete Manhole Sections
- Hatch to Drain Into Structure Unless Otherwise Noted
- Contact Phoenix for Hatch Requirements Exceeding these Dimensions

Options:

- LinkSeal Pipe Connections
- LinkSeal Electrical Connections
- Exterior Damp Proofing/Water Proofing
- Interior Coatings
- Interior Fill (Sloped Floor)
- Exterior Joint Wrap
- Aluminum Ladder
- "Ladder-Up" Safety Post
- Safety Net, Safety Grate
- Anti-Floatation Collar

Est Weights:

- Top Slab: 3,040 Lbs
- Risers: 1,280 Lbs/VF
- Sloped Floor: 640 Lbs
- Base Slab: 1,950 Lbs

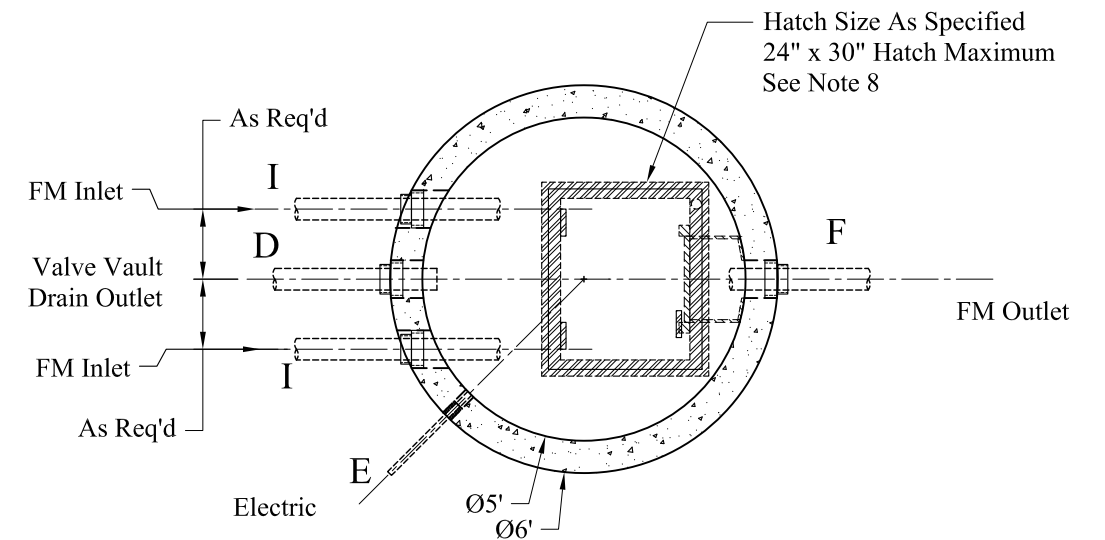

Phoenix
Precast
Products

5' Diameter
Valve Vault

P/N: Custom As Required