

Phoenix Precast Products

Phoenix Precast Products

Pipe Chart		
Pipe	Pipe OD	Connection
V		
E		
I		
F		
D		
B		

Elevation Chart	
Description	Elevation
R	Rim
G	Finish Grade
V	Vent
E	Electric Connection(s)
I	Inlet
F	Force Main Outlet
D	Drain Back from Valve Vault
B	Inside Bottom Floor
C	Outside Bottom of Concrete

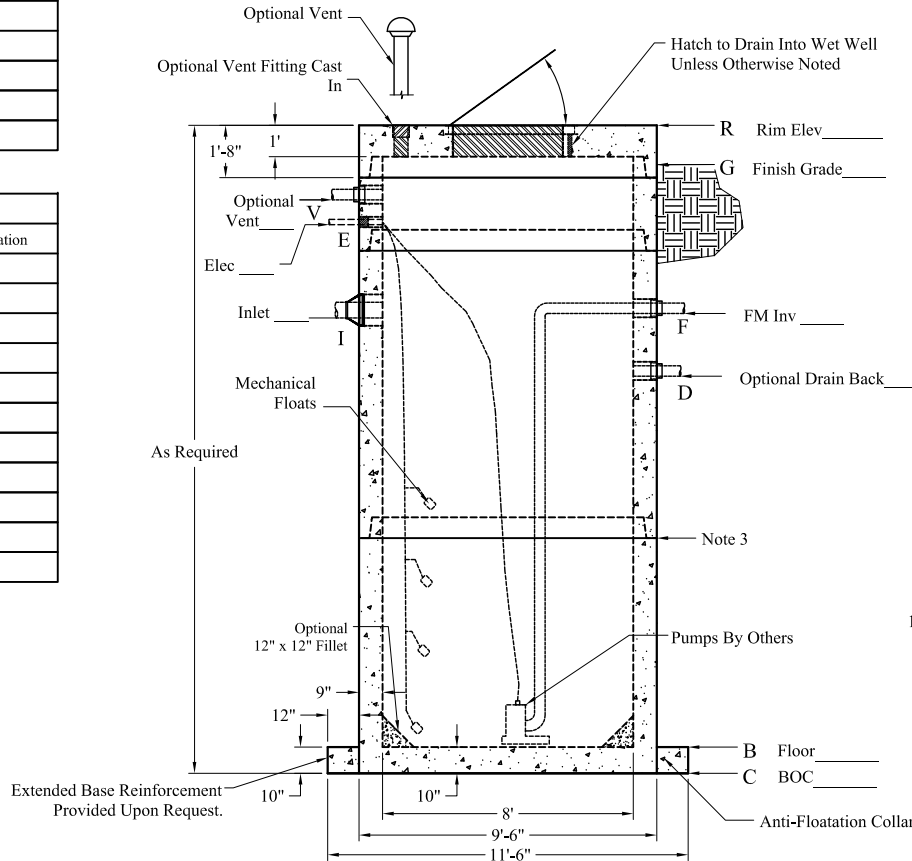

- 1.) Steel Reinforcement Conforms To Latest ASTM Specifications:
ASTM A-615 Grade 60 Black Deformed Bars
ASTM A-185 Welded Wire Fabric
- 2.) Concrete: $f_c = 5,000$ PSI @ 28 Days Minimum, Type III Cement
- 3.) Butyl Rubber Joint Sealant Conforms to ASTM C-990 and Federal Spec SS-S-210A.
- 4.) Flexible Connection Provided For All Pipe Connections.
- 5.) All Pumps, Mounting Hardware, and Related Ancillary Equipment Provided by Others.
- 6.) Liquid Capacity = 377 Gallons/Vertical Foot (31 Gallons/Inch)
- 7.) HS-20 Design Loading Conforms to Latest Specifications ASTM C478, AASHTO M199 Precast Reinforced Concrete Manhole Sections
- 8.) Hatch to Drain Into Wet Well Unless Otherwise Noted
- 9.) Based on Structural & Buoyancy Considerations, This Base Design May be Used with Pump Stations up to 30 Feet Deep Without Additional Engineering.
- 10.) Contact Phoenix for Hatch Requirements Exceeding these Dimensions

- Options:
- LinkSeal Pipe Connections
 - LinkSeal Electrical Connections
 - Exterior Damp Proofing/Water Proofing
 - Interior Coatings
 - Interior Fillet
 - Exterior Joint Wrap
 - Safety Net, Safety Grate
 - Winch Socket
- Est Weights:
- Top Slab: 11,800 Lbs
 - Risers: 3,040 Lbs/VF
 - 1' x 1' x 8'Ø Fillet: 3,250 Lbs
 - Ext Base Slab: 14,800 Lbs

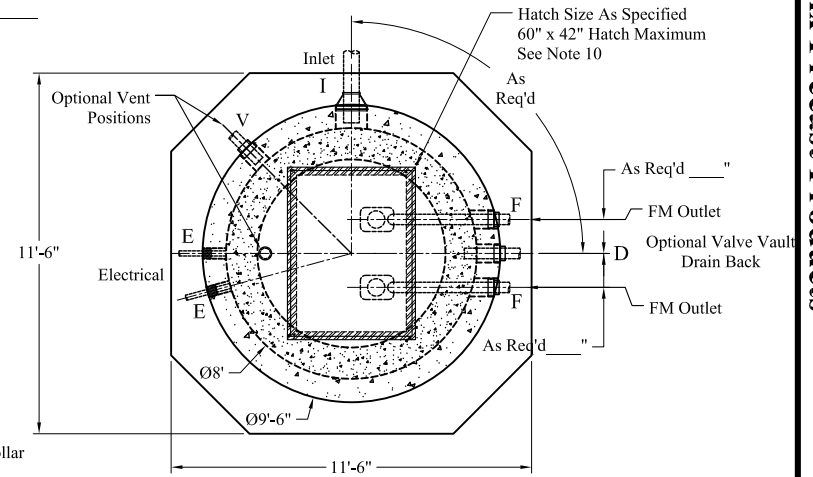

Phoenix Precast Products	8' Diameter Pump Station Wet Well Extended Base
	P/N: Custom As Required