

1-800-639-2199

Fax (603) 224-2927

Electrical Pull Boxes 30 x 30 x 24 Inch Pull Box (v)

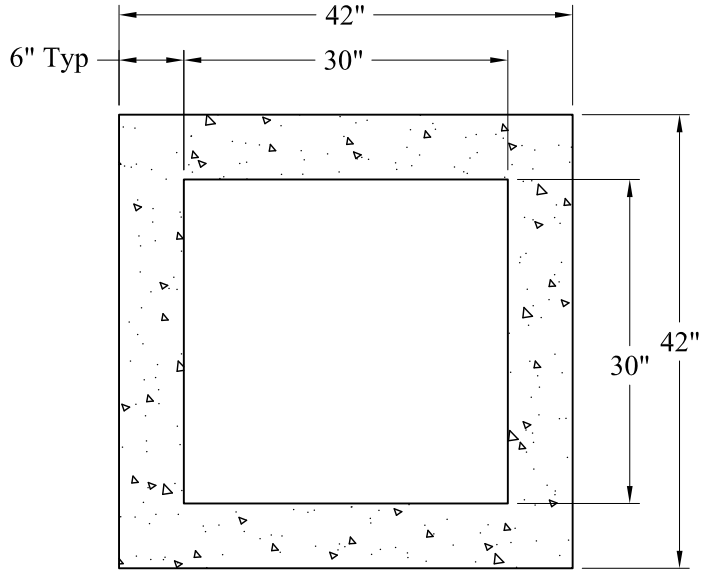
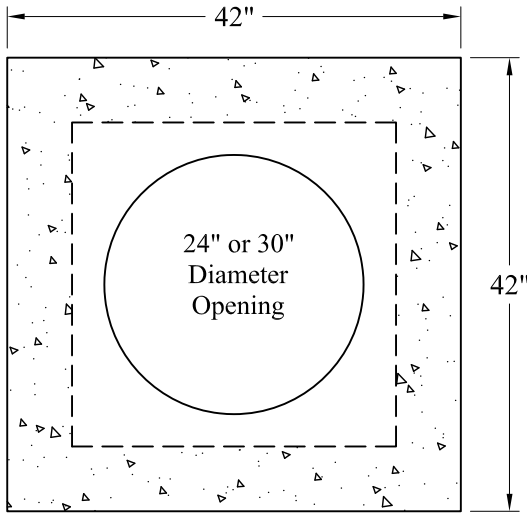

Optional Top Slab
(Est Weight: 675 Lbs)

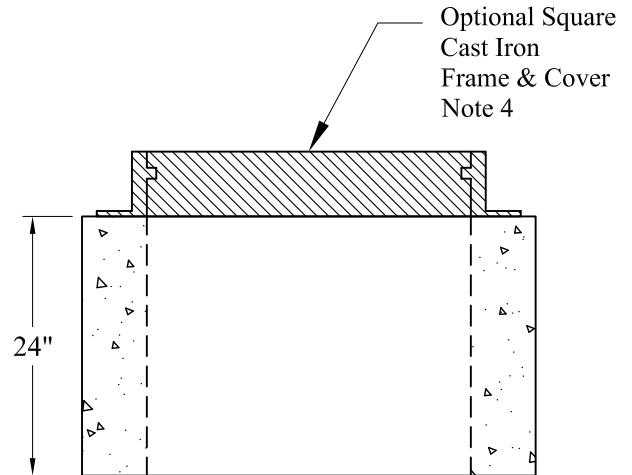
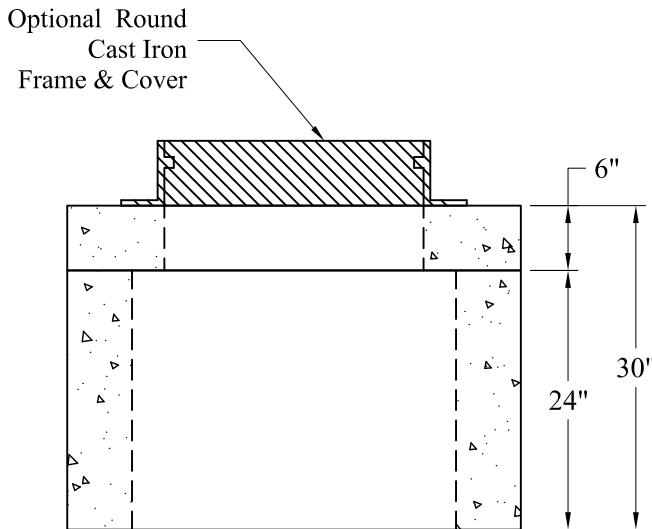

Est. Weight: 1,800 Lbs

General Notes

1. Concrete: $f_c = 4,000$ psi @ 28 Days Minimum
2. Reinforcing Steel: ASTM A615 Grade 60
3. Design Loading: AASHTO-HS20-44
4. Square Cover N1878 A9L

Phoenix
Precast
Products

30" x 30" x 24"
Pull Box

P/N: HH-30X30X24

Concord, NH 03301

Phoenix Precast Products

Phoenix Precast Products