

Plan View

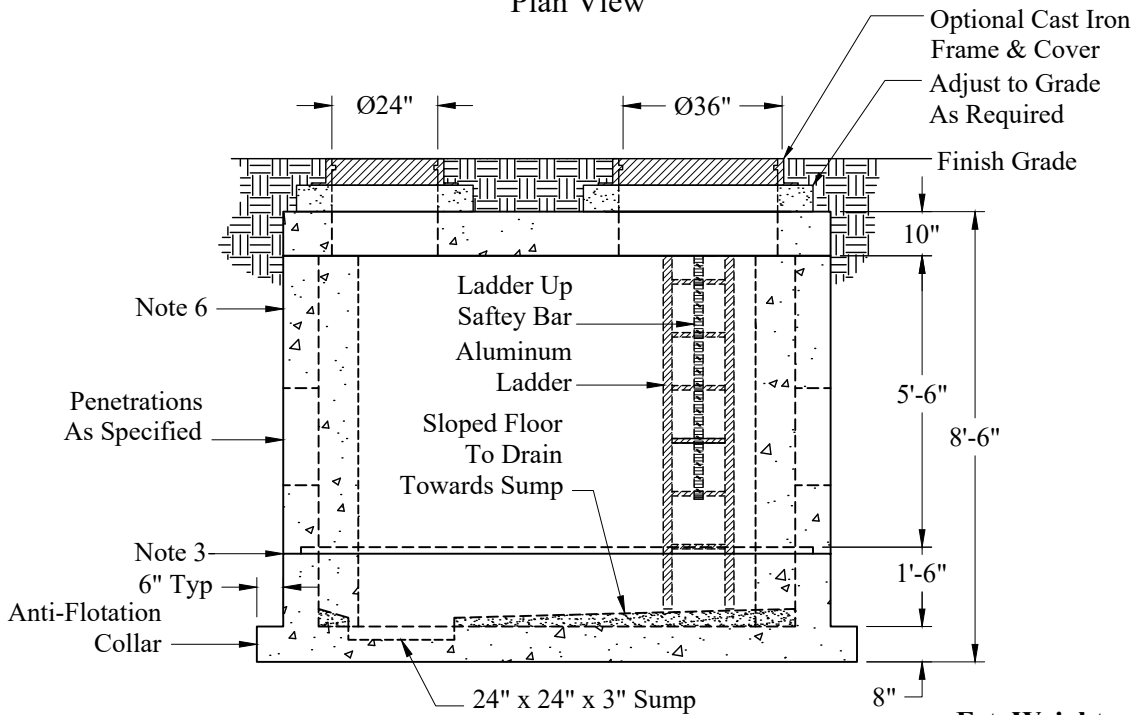

Elevation View

Est. Weights:

Top Slab:	13,600 Lbs
Riser:	22,120 Lbs
Base:	18,640 Lbs
Total:	54,360 Lbs

General Notes

1. Concrete: $f_c = 5,000$ psi @ 28 Days Minimum, Type III Cement
2. Steel Reinforcement Conforms to Latest ASTM Specification: ASTM A-615, Grade 60 Black Deformed Bars
3. Butyl Rubber Joint Sealant Provided Conforms to ASTM C-990 and Federal Spec SS-S-210A
4. Design Loading: AASHTO-HS20-44
5. Design Specification: per Latest ASTM C-857 & C858
6. Asphaltic Exterior Coating Available

Phoenix
Precast
Products

9' x 9' x 7'
Steam Vault

P/N: Custom As Required

Concord, NH 03301