

Recessed Handles 2 Places

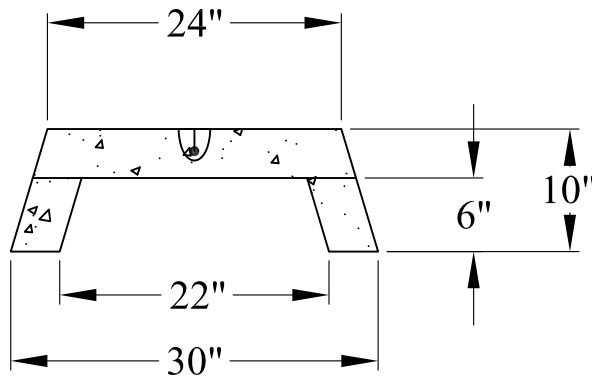
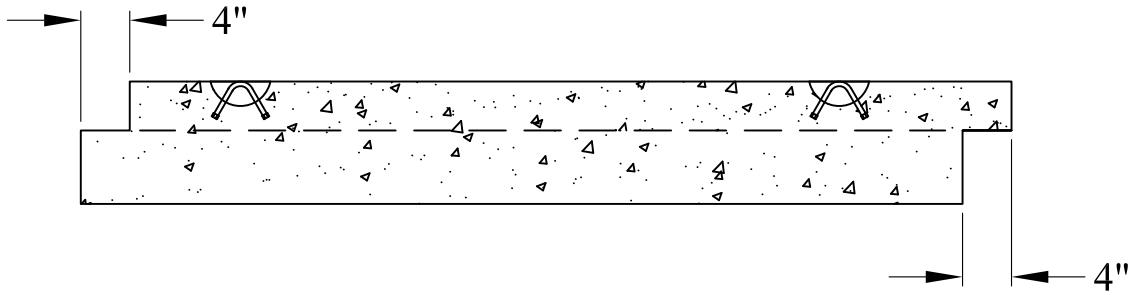

General Notes

1. Reinforcement Steel Conforms to: ASTM A185
2. Concrete: $f_c = 4,000$ psi @ 28 Days Minimum
3. Est. Weight: 2,110 Lbs

Phoenix
Precast
Products

NH Electric Co-Op
Underwater
Cable Cover

P/N: NHEC-UWCC

Concord, NH 03301