

Plan View - Top Slab

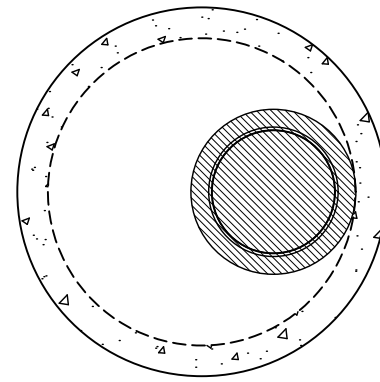

Plan View

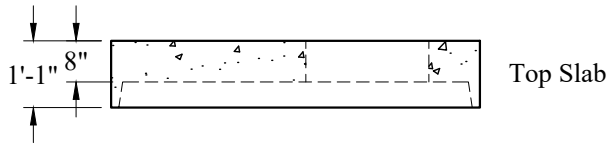

Top Slab

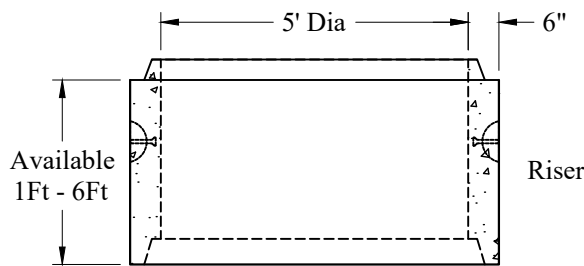

Riser

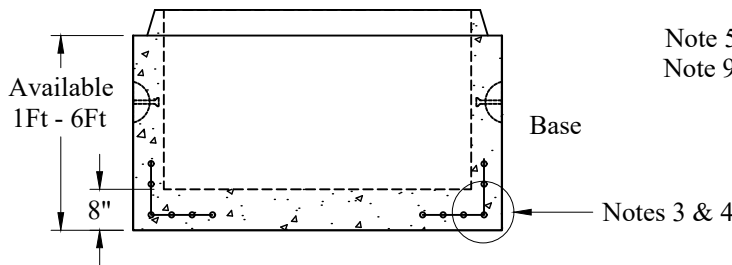

Base

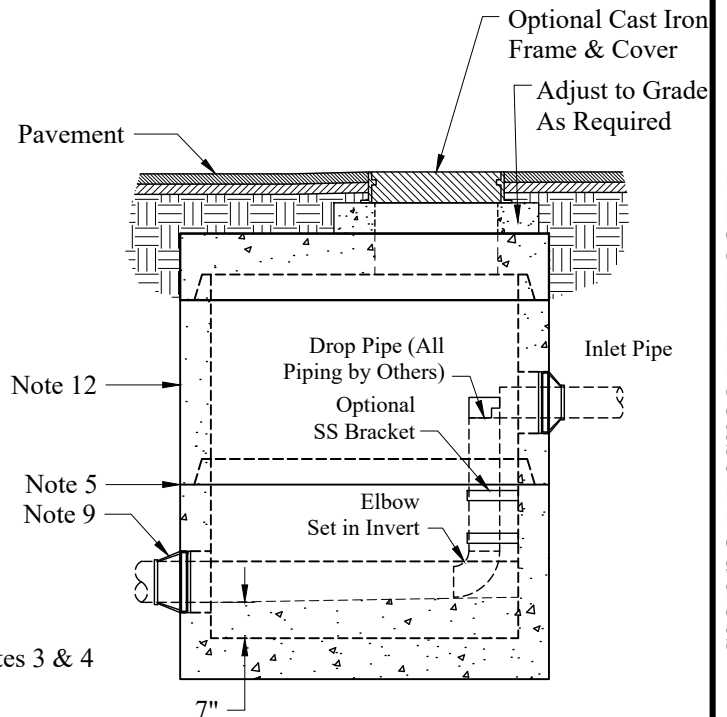

General Notes

1. Concrete: fc = 4,000 psi @ 28 Days Minimum, Type III Cement
2. HS-20 Design Loading Conforms to Latest Specifications ASTM C478, AASHTO M199 Precast Reinforced Concrete Manhole Sections
3. One Pour Monolithic Base Section
4. Steel Reinforcement Conforms to Latest ASTM Specification: ASTM A-615, Grade 60 Black Deformed Bars
ASTM A-185 Welded Wire Fabric
0.15 Sq. In./Lineal Ft. And 0.12 Sq. In. (Both Ways) Base Bottom
5. Butyl Rubber Joint Sealant Provided Conforms to ASTM C-990 And Federal Spec SS-S-210A
6. 147 Gallons/VF
7. Holes & Elevations TBD
8. Sections Available in Increments of 6"
9. Booted Pipe Connections (If Used) Conform to ASTM C-923. Maximum Booted Connection Pipe Size is 30"
10. Maximum Pipe OD is 44" (36" RCP)
11. Plastic Manhole Steps (If Required) are Steel Reinforced Conforming to ASTM C-478
12. Asphaltic Exterior Coating Available

Est Weights:

Top Slab:	3,040 Lbs
Wt/VF:	1,280 Lbs
Floor:	1,939 Lbs

Phoenix
Precast
Products

5' Diameter
Sanitary Manhole
Inside Drop

P/N: None

Concord, NH 03301