

Plan View - Top Slab

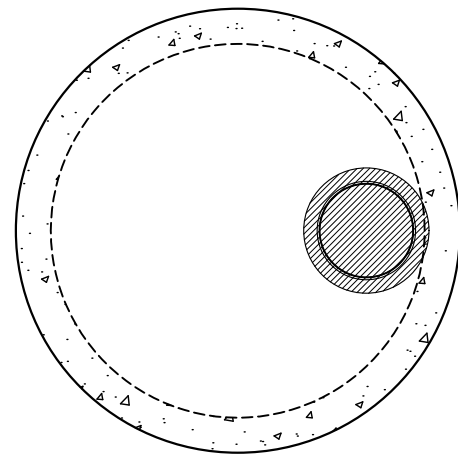

Plan View

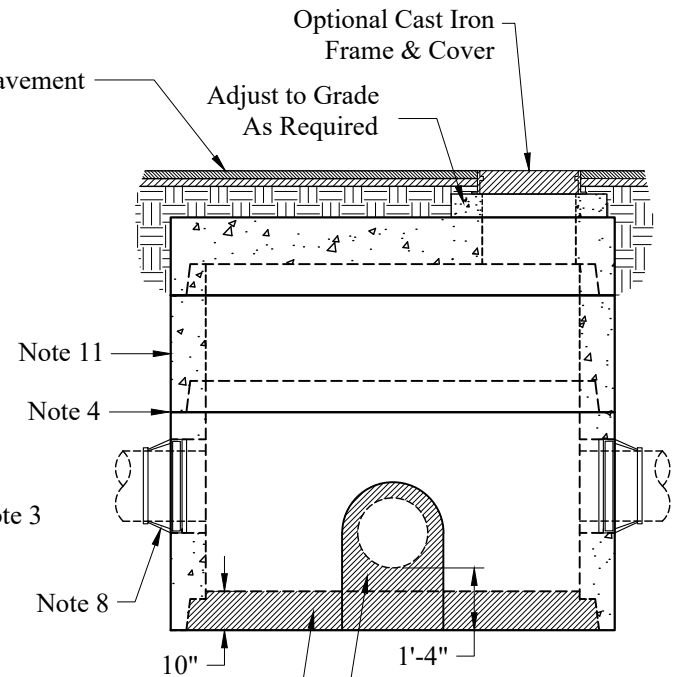
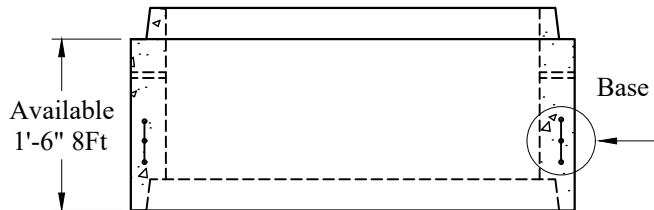
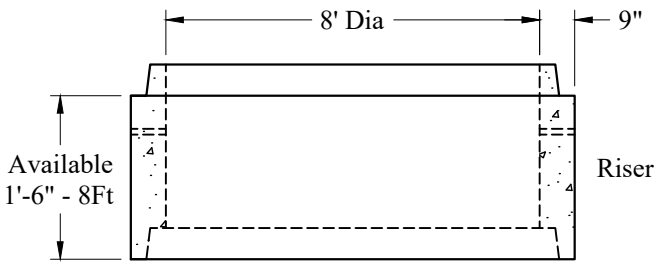
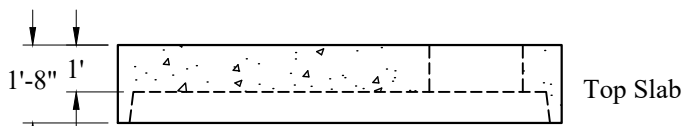

Floor is Cast in Place
By Others
After Setting Manhole

Mortar Joint
By Others

Est Weights:
Top Slab: 11,650 Lbs
Wt/VF: 3,040 Lbs

General Notes

1. Concrete: $f_c = 4,000$ psi @ 28 Days Minimum, Type III Cement
2. HS-20 Design Loading Conforms to Latest Specifications
ASTM C478, AASHTO M199 Precast Reinforced Concrete
Manhole Sections
3. Steel Reinforcement Conforms to Latest ASTM Specification:
ASTM A-615, Grade 60 Black Deformed Bars
ASTM A-185 Welded Wire Fabric
0.24 Sq. In./Lineal Ft. And 0.12 Sq. In.(Both Ways) Base Bottom
4. Butyl Rubber Joint Sealant Provided Conforms to ASTM C-990
And Federal Spec SS-S-210A
5. 377 Gallons/VF
6. Holes & Elevations TBD
7. Sections Available in Increments of 6"
8. Booted Pipe Connections (If Used) Conform to ASTM C-923.
Maximum Booted Connection Pipe Size is 48" RCP
9. Maximum Pipe OD is 79" (66" RCP)
10. Plastic Manhole Steps (If Required) are Steel Reinforced
Conforming to ASTM C-478
11. Asphaltic Exterior Coating Available

Phoenix Precast Products	8' Diameter Sanitary Manhole Doghouse
	P/N: None

Concord, NH 03301