

THE ELIMINATOR™

oil & floating debris trap for catch basins



EFFECTIVE

Eliminates oil and floating debris from the stormwater waste stream



ECONOMICAL

Low cost and ease of installation saves money



QUICK INSTALL

Eliminates prolonged exposure of workers in confined spaces as it installs in minutes



DURABLE

HDPE construction withstands the catch basin environment



MAINTAINABLE

Low contoured profile prevents dislodgment during cleaning. Large cleanout makes access to pipe easy

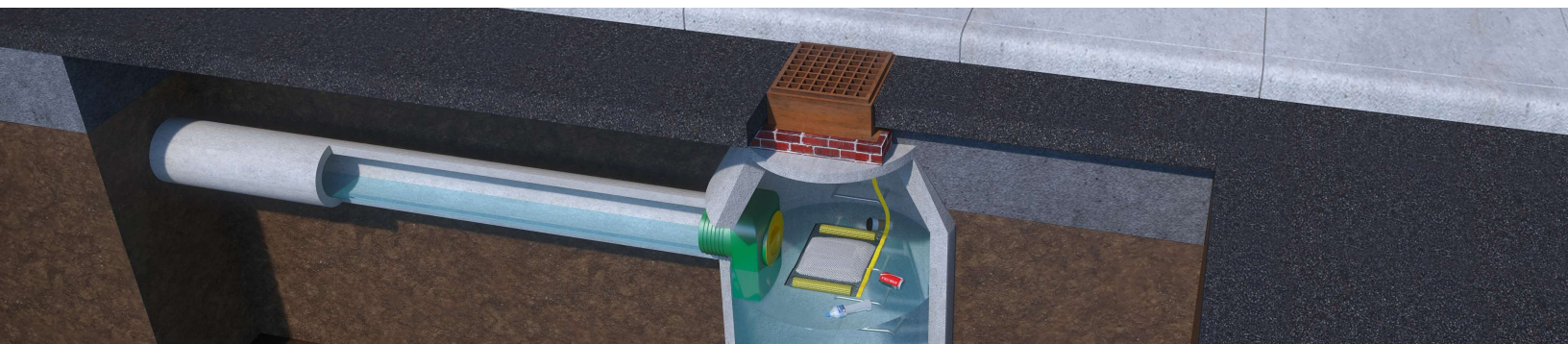

Ground Water Rescue, Inc.
24 Ryden St., Quincy, MA 02169
Tel: 617-773-1128 Fax: 617-773-0510
www.kleanstream.com



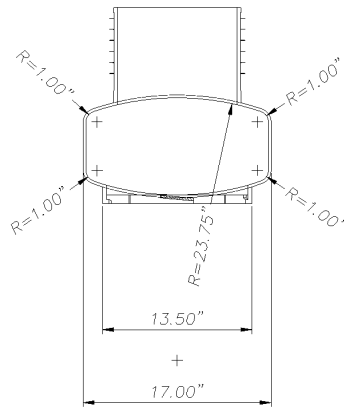

Enlarged Section 2-2

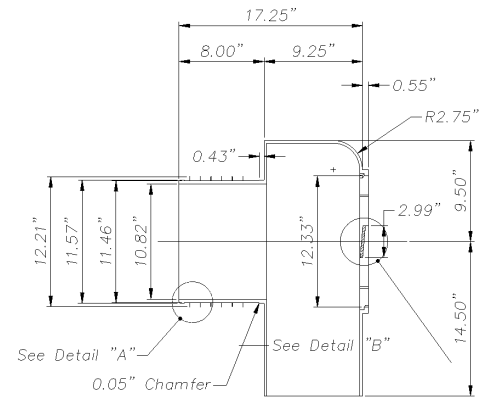

Enlarged Section 1-1

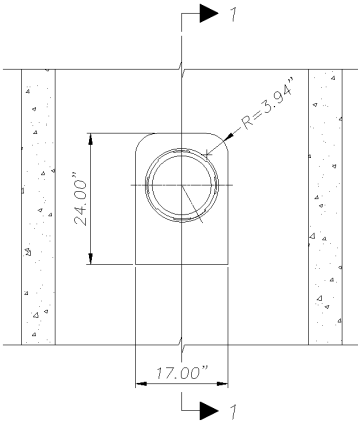

Front View

**The Eliminator Catch Basin
Oil & Debris Trap
Now Available
8" / 10" / 12" / 15" / 18"**

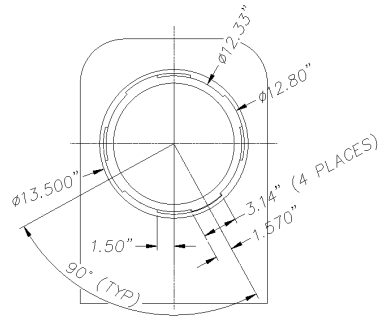

Enlarged Front View

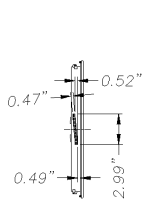

Side View of Cover

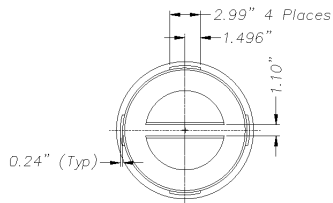

Rear View of Cover w/ Integral Handle

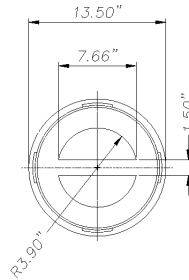

Front View of Cover w/ Integral Handle

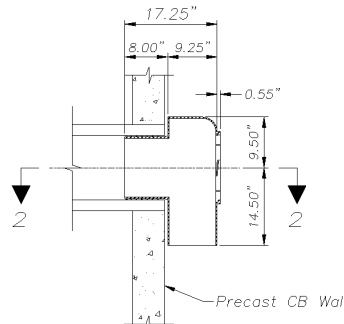

Section 1-1

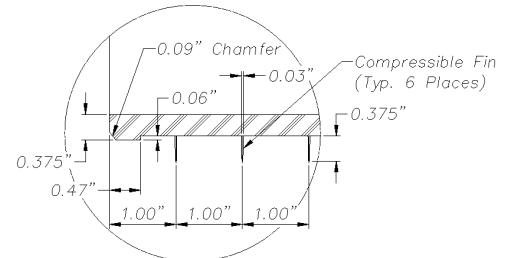

Detail "A"



Ground Water Rescue, Inc.
24 Ryden St., Quincy, MA 02169
Tel: 617-773-1128 Fax: 617-773-0510
www.kleanstream.com



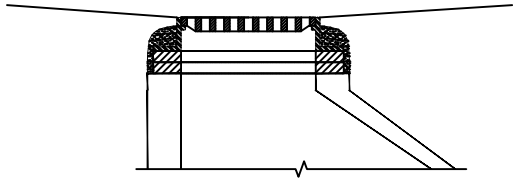

ALTERNATE ECCENTRIC CONE SECTION

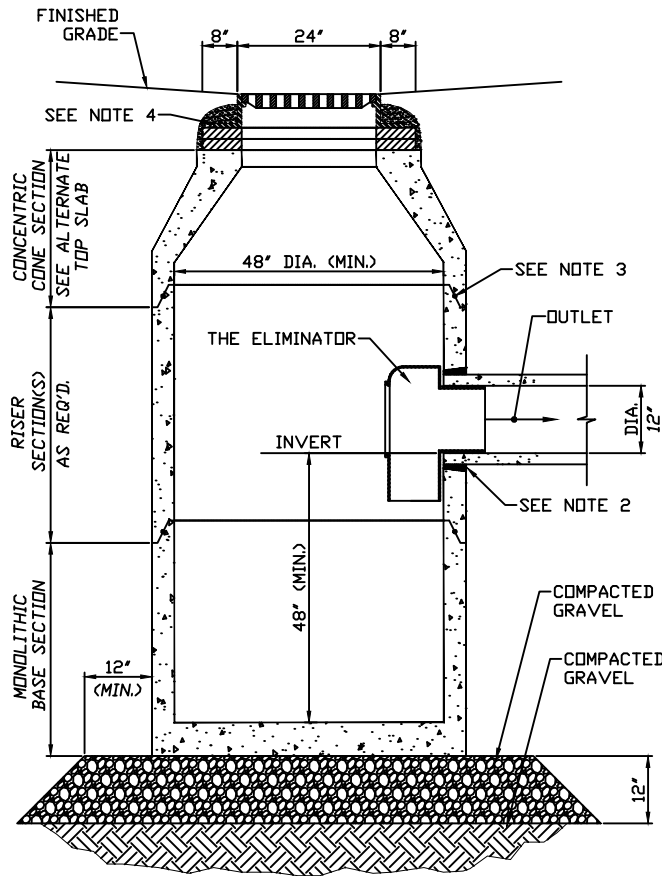

TYPICAL CATCH BASIN (CB) WITH TRAP

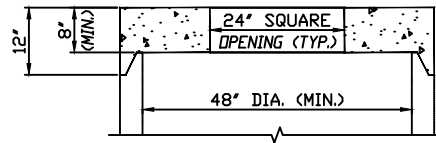

ALTERNATE TOP SLAB

Notes:

1. All Sections Shall Be Designed For HS-20 Loading
2. Provide "V" Kockouts For Pipes With 2" Max. Clearance To Outside Of Pipe. Mortar All Pipe Connections.
3. Joint Sealant Between Precast Sections Shall Be Preformed Butyl Rubber.
4. Catch Basin Frame And Grate Shall Be Set In Full Mortar Bed. Adjust To Grade With Clay Brick And Mortar.
(2) Brick Courses Typically.
(5) Brick Courses Maximum.
5. Hood Shall Be "The Eliminator" Oil & Floating Debris Trap As Manufactured By Ground Water Rescue, Inc. Quincy, MA. Tel. 617-773-1128 www.kleanstream.com

Phoenix Precast Products

Phoenix Precast Products

Eliminator Catch Basin Hood Part #'s	
Pipe Size	Phoenix Part #
8" Pipe	CBHOOD-E8
10" Pipe	CBHOOD-E10
12" Pipe	CBHOOD-E12
12" PVC Pipe	CBHOOD-E300
15" Pipe	CBHOOD-E15
18" Pipe	CBHOOD-E18

Phoenix Precast Products	"Eliminator" Catch Basin Hood Mfr'd by
	Ground Water Rescue, Inc.
P/N: See Above	