

Plan View

Outlet View

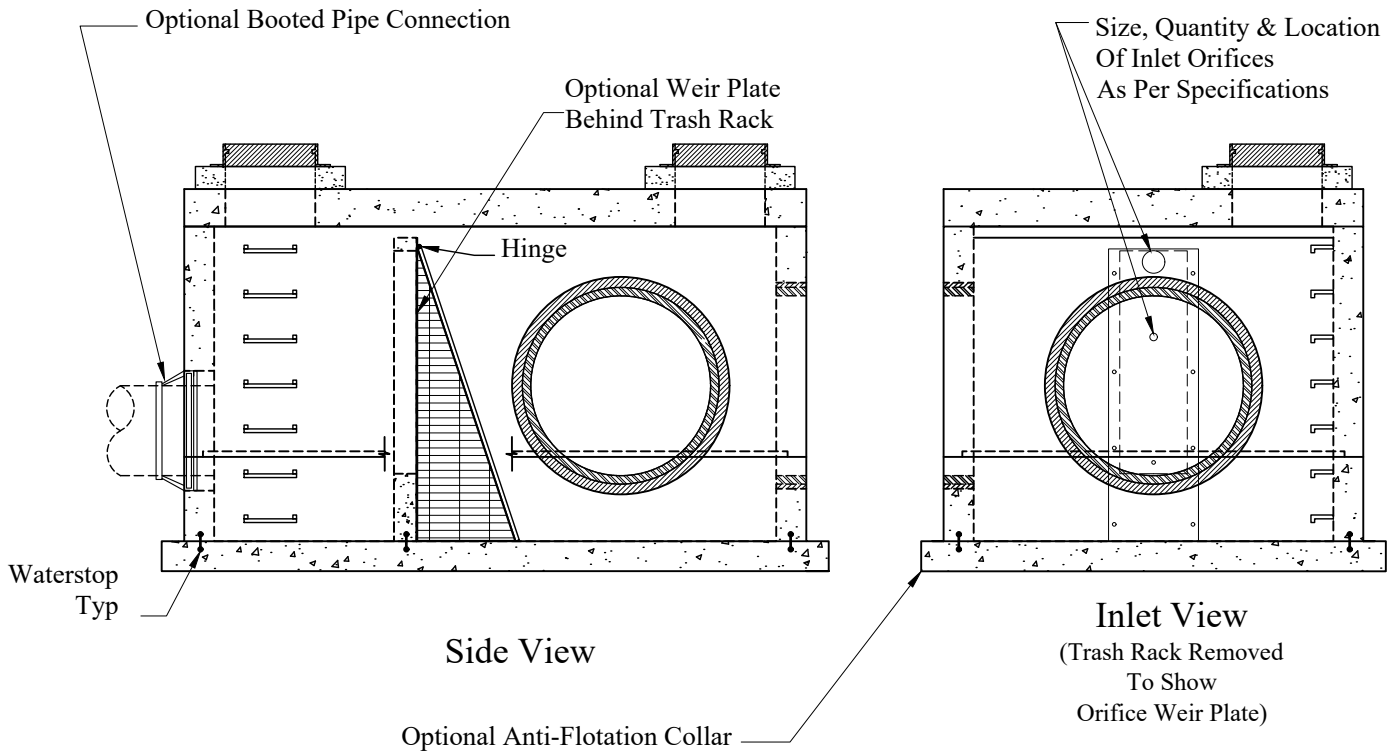

Side View

Inlet View
(Trash Rack Removed To Show Orifice Weir Plate)

General Notes

1. Concrete: $f_c = 5,000$ psi @ 28 Days Minimum, Type III Cement
2. Steel Reinforcing Conforms to Latest ASTM Specifications
ASTM A-615 Grade 60 Rebar
3. Design Loading: AASHTO-HS20-44
4. Grates/Trash Racks Fastened with SS Hardware
5. Grates/Trash Racks Finish Options: Galvanized, Painted, Or Unfinished

**Phoenix
Precast
Products**

**Custom
High Volume Outlet
Control Structure**

P/N: Custom As Required

Concord, NH 03301