

Product Catalog

Architectural & Industrial Grating Solutions



OHIO GRATINGS, INC.

INDUSTRIAL GRATING SOLUTIONS

Light Duty Steel Grating

Ohio Gratings offers a wide variety of light duty steel grating styles including electro forge welded, dove tail pressure locked, riveted and swaged...



Organic Tech. OH - Lt. Duty

Electro forge welded grating is the more traditional industrial product while dove tail pressure locked, riveted and swaged offer smoother lines and a more pleasing appearance than the typical welded grating. These products appeal to the architectural market and

offer a different look that can be used not only for industrial applications but also commercial applications where a higher profile product might be desired. The dove tail and swaged products are also part of our Grater Access® line of products conforming to ADA standards. OnGrip® Spray Traction Surface is also available.

Aluminum Plank

Aluminum plank is a very versatile product. It is available unpunched or in a variety of punch patterns. OnGrip® Spray Traction Surface is also available. Aluminum plank is ideal for multiple industrial applications, everything from wastewater treatment plants to ADA compliant walkways (shown right) and platforms.



Grosse Ile Bridge, MI - Aluminum Plank Walkway

Heavy Duty Steel Grating

Welded carbon heavy duty steel grating is the most popular choice where high strength is the primary grating requirement. Another option that meets ADA standards is Wheels n' Heels®...



Tree Gate - Wheels n' Heels®

The main bars are slotted and assembled with cross bars which are welded with one fillet weld at every joint. Stainless steel can also be provided for those high corrosive applications. This product meets the demanding vehicle loading requirements of

AASHTO and is geared to handle heavy rolling loads. OnGrip® Spray Traction Surface is also available.

The typical markets for heavy duty steel grating include: ramps, docks, industrial flooring, industrial cover trenches, airfield ramps & trenches, airplane landing mats, machinery support trenches, bridge decking, bridge sidewalks, bridge trenches and many more applications.



▲ Grosse Ile Bridge in Michigan - Heavy Duty Riveted

THE OHIO GRATINGS STORY

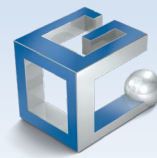

OGI has rallied around one key principle over the years
...***“Make it Right & Ship When Promised”***



OHIO GRATINGS HOME OFFICE IN CANTON, OH ▲

Since 1970, our motto has allowed us to expand successfully over the years. OGI began as a light duty steel grating fabricator and expanded into the manufacturing of heavy duty welded steel and stainless steel grating. That early success led to other expansions including the manufacturing of aluminum swaged and dovetail bar grating. A few years later we added aluminum plank to our line of flooring products and then finally fiberglass to round out our product offerings.

This experience has led us into other markets in addition to the traditional industrial flooring market. OGI now has the ability to provide a myriad of aluminum and steel architectural products to the marketplace. Our manufacturing capabilities and engineering know-how allow us to work with owners, suppliers, architectural and engineering firms.



Our special support team can help you meet all your unique design requirements, quickly and professionally...

- ▶ **Detailing Support** - Working from customer supplied drawings, our detailing group provides professional detailed shop drawings to insure a successful grating project.
- ▶ **Value Engineering** - Our on-staff engineers & detailers check & double check all the calculations to make sure the grating for your project meets or exceeds your structural expectations.
- ▶ **Custom Fabrication** - All types of custom fabrication are required on industrial projects. OGI has built grating panels and fabricated these projects for well over 25 years. Typical fabrication consists of straight cut, straight band, circular cut, circular band, end band, toe plate attachment and adding checker plate to the top of the grating.
- ▶ **Design & Custom Layout** - Our sales and detailing department can help with the grating design and layout to optimize and value engineer the grating on any type of project. We provide solutions, not just grating. Call today to let us help with your next opportunity.



INTERSTATE GRATINGS, UT ▲



▲ HOUSTON, TX

Our expansions in Utah and Texas demonstrate our commitment to service...

Our facilities are strategically located to help us reach beyond the midwest and provide faster service to all of our current and future customers throughout the U.S.

All of our products are manufactured in the United States.

TABLE OF CONTENTS

GENERAL INFORMATION

Industrial Grating Solutions	2
Ohio Gratings Story	3
Table of Contents	4

ALUMINUM GRATING

Aluminum Features & Benefits	5
Aluminum Products	6
Aluminum Design Criteria	7
SG Series - Aluminum Rectangular Bar	8
SGI Series - Aluminum I-Bar	9
SGF Series - Aluminum Flush Top	10
ADT Series - Aluminum Dove Tail	11
19-Space Aluminum Profiles & Load Tables	12-13
15-Space Aluminum Profiles & Load Tables	14-15
11-Space Aluminum Profiles & Load Tables	16-17
7-Space Aluminum Profiles & Load Tables	18-19
SGLi Series - Aluminum LiteBar	20
19 & 15-Space Aluminum LiteBar Load Tables	21
11 & 7-Space Aluminum LiteBar Load Tables	22
AR Series - Aluminum Riveted	23
18-Space Aluminum Riveted Profiles & Load Tables	24
12-Space Aluminum Riveted Profiles & Load Tables	25
Aluminum Plank	26-27
Aluminum Plank Punch Pattern	27-28
Aluminum Plank Fabrication	28
Aluminum Plank Load Tables	28-29
Aluminum Plank F Treads	30
Aluminum Plank Applications	31
Aluminum Grating Frames	32-33

STAIR TREADS

Stair Tread Features & Benefits	34
Aluminum & Steel Stair Tread Details	35
Aluminum Stair Tread Profiles & Load Tables	36
Steel Stair Tread Profiles & Load Tables	37

LIGHT DUTY STEEL GRATING

Light Duty Steel Features & Benefits	38
Light Duty Steel Products	39
Light Duty Steel Design Criteria	40
W Series - Light Duty Welded Steel	41
DT Series - Steel Dove Tail	42
SGCS Series - Swaged Carbon Steel	43
19-Space Light Duty W, DT & SGCS Series Profiles & Load Tables	44-45
15-Space Light Duty W, DT & SGCS Series Profiles & Load Tables	46-47
11-Space Light Duty W, DT & SGCS Series Profiles & Load Tables	48-49
7-Space Light Duty W, DT & SGCS Series Profiles & Load Tables	50-51
R Series - Light Duty Riveted Steel	52
18-Space Light Duty R Series Profiles & Load Tables	53
12-Space Light Duty R Series Profiles & Load Tables	54
Light Duty MBG PressLock	55
MBG PressLock Construction	56
Technical Data	57
Fasteners & Profiles	58

MBG PressLock Applications & Load Tables	59-60
--	-------

STAINLESS STEEL

SGSS Series - Swaged Stainless Steel	61
19-Space Stainless Steel SGSS Series Profiles & Load Tables	62
15-Space Stainless Steel SGSS Series Profiles & Load Tables	63
11-Space Stainless Steel SGSS Series Profiles & Load Tables	64
7-Space Stainless Steel SGSS Series Profiles & Load Tables	65

HEAVY DUTY STEEL GRATING

Heavy Duty Steel Features & Benefits	66
Heavy Duty Steel Products	67
Heavy Duty Steel Design Criteria	68
W Series - Heavy Duty Steel	69
38-Space Heavy Duty W Series Profiles & Load Tables	70-71
30-Space Heavy Duty W Series Profiles & Load Tables	72-73
22-Space Heavy Duty W Series Profiles & Load Tables	74-75
19-Space Heavy Duty W Series Profiles & Load Tables	76-77
15-Space Heavy Duty W Series Profiles & Load Tables	78-79
Steel Grating Frames	80
Wheels n' Heels® Heavy Duty Steel	81
Wheels n' Heels® Metro™ Heavy Duty Steel	82
28-WH-4 Wheels n' Heels® Metro® Profiles & Load Tables	83
33-WH-4 Wheels n' Heels® Metro® Profiles & Load Tables	84
42-WH-4 Wheels n' Heels® Metro® Profiles & Load Tables	85
44-WH-4 Wheels n' Heels® Metro® Profiles & Load Tables	86
Wheels n' Heels® InVent™ Heavy Duty Steel	87
64-7-WH-63 1/8" Wheels n' Heels® InVent® Profiles & Load Tables	88
64-7-WH-63 3/16" Wheels n' Heels® InVent® Profiles & Load Tables	89
64-10-WH-60 1/8" Wheels n' Heels® InVent® Profiles & Load Tables	90
64-11-WH-66 3/16" Wheels n' Heels® InVent® Profiles & Load Tables	91
R Series - Heavy Duty Rivered Steel	92
37-Space Heavy Duty R Series Profiles & Load Tables	93

FABRICATION

Anchoring Devices	94
Standard Practices	95
Specification Information	96
ADA Guidelines	97
Nomenclature & Vocabulary	98
Pressure Locked Grating	99
Custom Fabrication	100-102
Standard Installation Clearances	103
Grating Tolerances	104-105
Welding Standards	106-107

RESOURCES

Glossary	108-109
Ordering Information	110
Architectural Metal Solutions	111

ALUMINUM FEATURES & BENEFITS

Aluminum Provides a Unique Combination of Properties

...which makes it one of the most versatile engineering and construction materials available today!!

As a natural resource, aluminum is our most abundant metallic element. Its light weight mass (about a third the weight of copper or steel), unmatched strength-to-weight ratio and excellent corrosion resistance under the majority of service conditions makes it an excellent material for the manufacturing of bar grating.

Aluminum can be recycled and as a result, makes it an environmentally friendly material unlike some other grating material. Aluminum is durable and will offer years of service without showing wear or decay. It is also non-toxic so it can be easily cleaned and does not absorb bacteria sustaining particles. As a result it is a good candidate for food processing facilities. The material is also resilient; it can deflect under loads and then spring back.

All these attributes make aluminum grating an ideal solution for many special grating applications such as: sewage and waste water treatment plants, off-shore drilling rigs, the chemical processing industry, the paper mill industry and marine superstructure applications. Because of its natural attractiveness, aluminum grating is also used in many architectural and commercial applications including sun screens, ceiling tiles, vent grilles, fencing, building facades, fountains, nature and wildlife walkways, and entranceways.



Aluminum is the “Lightweight Champion”

Reasons Why:

- Aluminum is Non-Toxic
- Aluminum is Light Weight
- Aluminum is Durable
- Aluminum is our Most Abundant Metallic Element
- Aluminum has Excellent Corrosion Resistance
- Aluminum is Resilient
- Aluminum has High Strength-to-Weight Ratio
- Aluminum can be Customized in the Field
- Aluminum can be Easily Recycled
- Aluminum is Naturally Attractive
- Aluminum is Versatile



ALUMINUM PRODUCTS



Aluminum Rectangular, I-Bar & LITEBAR.

SG Series, SGI Series & SGLi Series

A type of pressure locked grating made by permanently attaching cross bars to bearing bars through a pressure applied swaging process. Bearing bars are either rectangular or "I" shaped and range in size from 1" through 2-1/2". Both Rectangular Bar and I-Bar are offered in 1-3/16" and 15/16" spacings, as well as ADA (Sept. 2010) compliant spacings. Cross bars are available on 4" and 2" centers. A serrated surface (rectangular bar) or striated surface (I-Bar) is available for skid resistance. OnGrip® Spray Traction Surface is also available.



Aluminum Flush Top

SGF Series

A type of pressure locked grating in which the cross bars are in the same plane relative to the top surface of the grating. Bearing bar sizes range from 1" x 1/8" through 2-1/2" x 3/16" in 1/4" increments. Bearing bar spacing of 1-3/16", 15/16", 1 1/16" and 7/16" c.c. and cross bar spacing of 4" or 2" are available. Where skid resistance is desired, a serrated surface can be provided. Aluminum Flush Top is available in spacings which provide a 1/4" or 1/2" opening in conformance with provisions of the ADA for grating products. OnGrip® Spray Traction Surface is also available.



Aluminum Dove Tail

ADT Series

A type of pressure locked grating where bearing bars and cross bars are precision slotted, assembled in egg-crate fashion, and hydraulically pressed together to form a panel grid. Bearing bars range from 1" x 1/8" through 2-1/2" x 3/16" in 1/4" increments. Grating spacings for Aluminum Dove Tail include the standards, as well as the ADA (September 2010) compliant spacings. Many engineers prefer the bi-directional, rectilinear look and feel of Aluminum Dove Tail grating. OnGrip® Spray Traction Surface is also available.

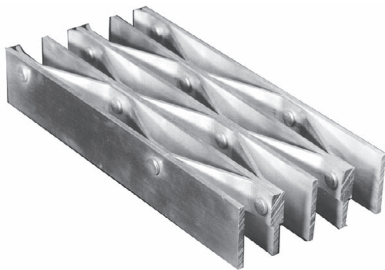

Aluminum Riveted

AR Series

A type of aluminum grating which combines straight bearing bars and bent connecting bars riveted together at their contact points. Riveted grating, although being the oldest style of industrial footwalk, is still the choice of many engineers due to its reliability and durability. All popular sizes and spacings of riveted grating are manufactured by Ohio Gratings with an emphasis on quality and service. OnGrip® Spray Traction Surface is also available.

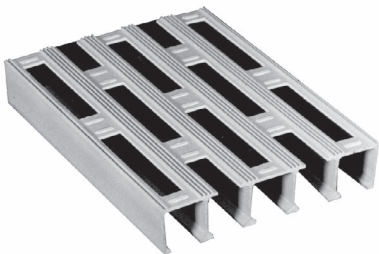

Aluminum Plank

A type of aluminum grating which is available in 6" wide sections, and either plain sided or interlocking. Plank can be provided in sections up to 26' 0" in length, or fabricated per plans and specs. Plank grating is available unpunched as an economical and structurally superior substitute for aluminum checkerplate, or with a variety of punch/patterns. OnGrip® Spray Traction Surface is also available.

ALUMINUM DESIGN CRITERIA

The tables of safe loads which follow have been computed using the following design parameters:

- U** = Uniform Load - lbs/ft²
- C** = Concentrated Load - lbs/ft of grating width
- S** = Section Modulus - in³/ft of grating width
- I** = Moment of Inertia - in⁴/ft of grating width
- L** = Simple Clear Span - feet
- D** = Deflection - inches
- E** = Modulus of Elasticity (10,000,000 psi)
- F** = Allowable Bending Stress (12,000 psi)
See note below
- M** = Bending Moment

Design Service

Available at no charge to the specifying architect/engineer or fabricator, is access to a computer program which provides uniform load and deflection (actual or fraction of span) analysis of grating products. Just call, write or fax your design criteria – loading, span, allowable deflection, or grating size desired – and we will provide you with the information you require.

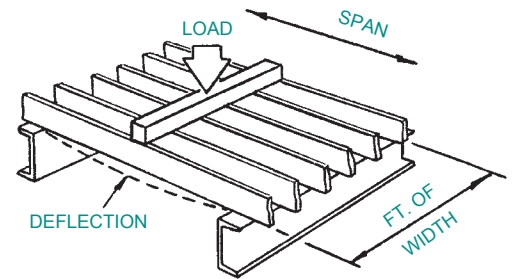
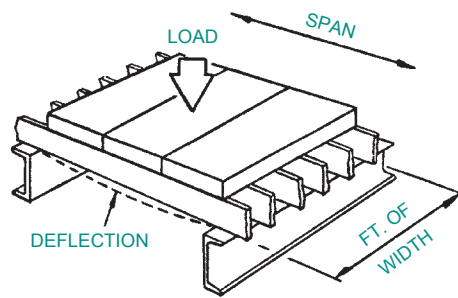

	Uniform Load	Concentrated Load
Step 1. Determine M:	$M = \frac{FS}{12}$	$M = \frac{FS}{12}$
Step 2. Determine U or C:	$U = \frac{8M}{L^2}$	$C = \frac{4M}{L}$
Step 3. Check D*:	$D = \frac{5UL(L \times 12)^3}{384 EI}$	$D = \frac{C(L \times 12)^3}{48 EI}$

*Deflection should be limited to 1/4" under 100# uniform load to afford pedestrian comfort.

Aluminum Grating is best suited for use in conjunction with pedestrian traffic, and for very light, rubber pneumatic tired rolling traffic (carts, dollies and hand trucks). For other rolling loads (forklifts, cars, trucks, etc.) see the Heavy Duty Steel Grating section, page 67.

Information of a technical nature contained herein is intended only for evaluation by technically skilled persons, with any use thereof to be at their independent discretion and risk. Such information is reliable when evaluated in the proper manner under conditions as described herein. Ohio Gratings, Inc. shall have no responsibility or liability for results obtained or damages resulting from improper evaluation or use.

ALUMINUM RECTANGULAR BAR



SG SERIES

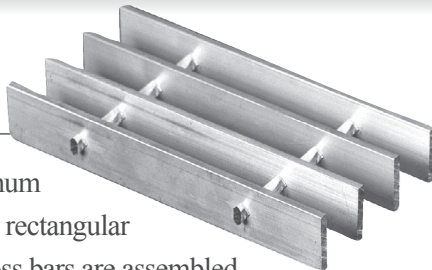

The most widely used aluminum pressure locked grating is the rectangular bar SG series. The square cross bars are assembled through punched diamond shaped holes in rectangular bearing bars and are permanently locked into place by a swaging process.

It provides clean crisp lines using recessed cross bar and eliminates the need for any type of welding to form the panels. By using the most modern technology available, swaged bar grating allows for a variety of spacings including those that conform to the “Americans with Disabilities Act”. Because of its aesthetic appeal and the ability to meet tight tolerances, this product is often used for architectural applications. OnGrip® Spray Traction Surface is also available.

Serrated surface also available.

***8 Space available upon request.**

GRATING PROFILES AVAILABLE...

SG SERIES Aluminum Rectangular Bar

All profiles shown below are also available with 2" cross bar centers. Product numbers would be 19-SG-2, 15-SG-2, 11-SG-2 and 7-SG-2

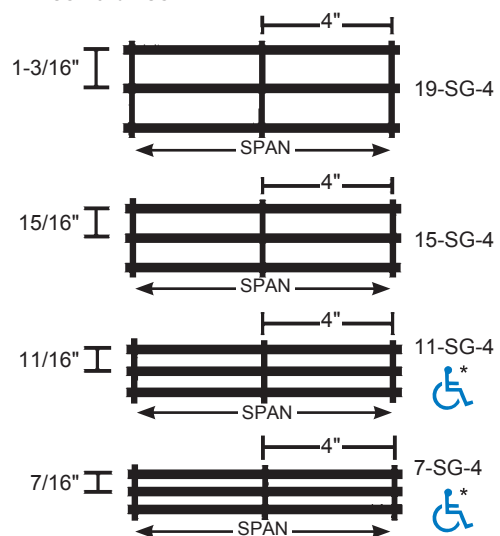

See load tables beginning on page 12.

***Note:** Conforms with the spacing requirements of ADA (September 2010) when installed with the elongated opening perpendicular to the dominant direction of travel. See ADA Guidelines

ALUMINUM I-BAR



SGI SERIES

The I-Bar SGI Series offers a popular and reasonably priced alternative to rectangular bar grating. Extruded I-Bar sections have the same load carrying capacity with less weight per square foot than rectangular bars.

The striated top and bottom flanges provide a “built-in” skid resistance feature without the added cost of serration. On-Grip® Spray Traction Surface is also available.

Our closest mesh ▼

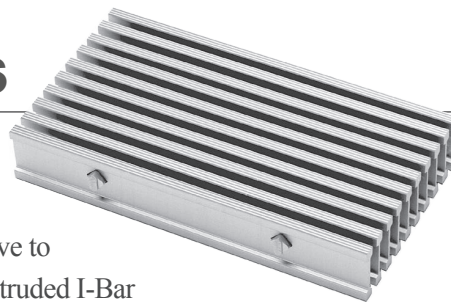

End view ►



GRATING PROFILES AVAILABLE...

SGI SERIES Aluminum I-Bar

All profiles shown below are also available with 2" cross bar centers. Product numbers would be 19-SGI-2, 15-SGI-2, 11-SGI-2 and 7-SGI-2

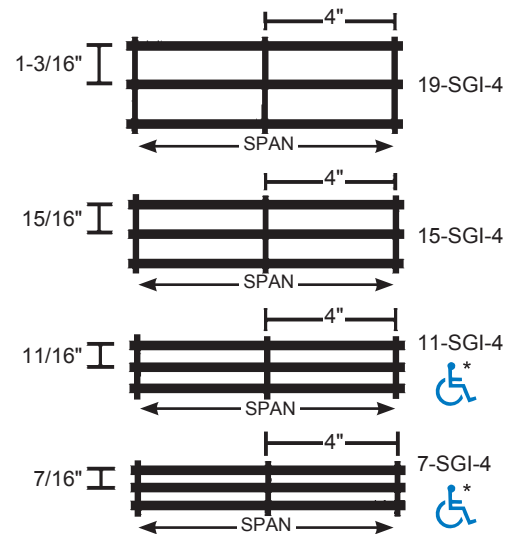

See load tables beginning on page 12.

*Note: Conforms with the spacing requirements of ADA (September 2010) when installed with the elongated opening perpendicular to the dominant direction of travel. See ADA Guidelines

ALUMINUM FLUSH TOP



SGF SERIES



Maximum walking surface, cosmetic appeal, economy of shop fabrication and ease of field alteration make the Aluminum Flush Top series the premier choice when pressure locked aluminum grating is being specified. This series offers a type of pressure locked grating in which the cross bars are in the same plane relative to the top surface of the grating. For those areas that receive a great deal of pedestrian traffic, our 1/4" opening 7-SGF-4 close space product is available which conforms with the provisions of the "Americans with Disabilities Act".

OnGrip® Spray Traction Surface is also available.

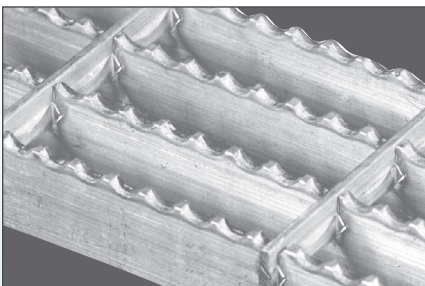

◀ **Serrated surface also available**

***8 Space available upon request.**

GRATING PROFILES AVAILABLE... SGF SERIES Aluminum Flush Top

All profiles shown below are also available with 2" cross bar centers. Product numbers would be 19-SGF-2, 15-SGF-2, 11-SGF-2 and 7-SGF-2

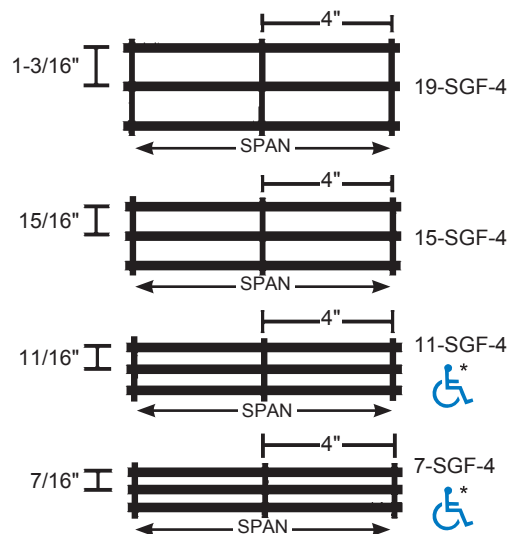

See load tables beginning on page 12.

*Note: Conforms with the spacing requirements of ADA (September 2010) when installed with the elongated opening perpendicular to the dominant direction of travel. See ADA Guidelines

ALUMINUM DOVE TAIL



ADT SERIES

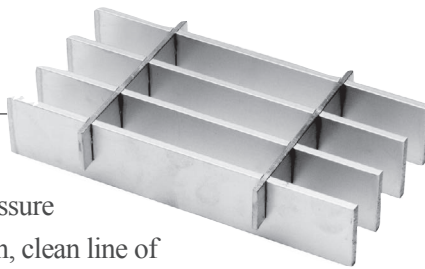

Traditionally designed, Aluminum Dove Tail slot pressure locked grating offers a smooth, clean line of a flush top rectangular cross bar. Bearing bars and cross bars are precision slotted, assembled in egg-crate fashion and hydraulically pressed together to form a tightly locked, rigidly stable panel grid. This grating is available in spacings, which provide a 1/4" or 1/2" opening in conformance with provisions for the "Americans with Disabilities Act" (v). These products are part of our Grater Access line and are available with cross bars on 2" or 4" centers. This is also a popular style in the architectural community because of the aesthetic eye appeal of the product and the ability to maintain tighter tolerances. OnGrip® Spray Traction Surface is also available.

Serrated surface also available.

***8 Space available upon request.**

GRATING PROFILES AVAILABLE...

ADT SERIES Aluminum Dove Tail

All profiles shown below are also available with 2" cross bar centers. Product numbers would be 19-ADT-2, 15-ADT-2, 11-ADT-2 and 7-ADT-2

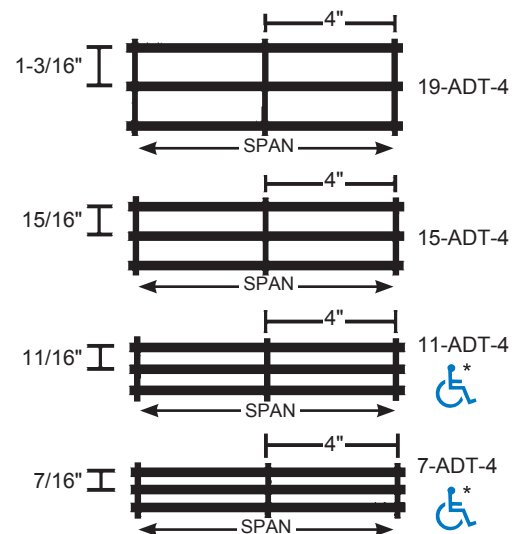

See load tables beginning on page 12.

***Note:** Conforms with the spacing requirements of ADA (September 2010) when installed with the elongated opening perpendicular to the dominant direction of travel. See ADA Guidelines

19 SPACE PROFILES

ALUMINUM RECTANGULAR BAR

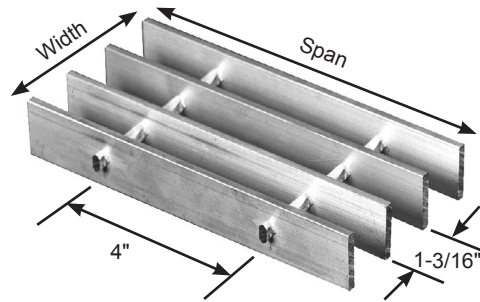

19-SG-4

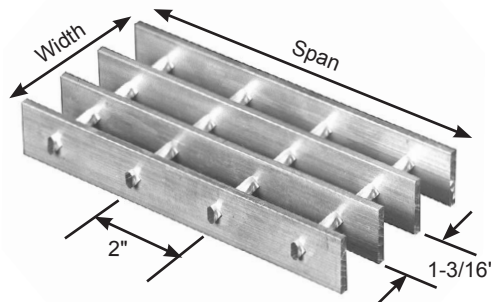

19-SG-2

% Open Area*		
Bars	1/8"	3/16"
4" cc	85%	80%
2" cc	81%	77%

ALUMINUM I-BAR

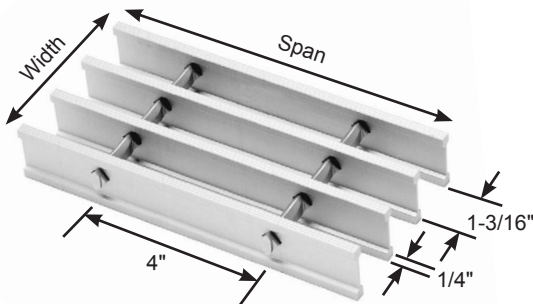

19-SGI-4

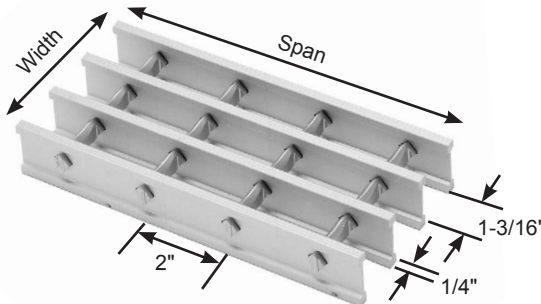

19-SGI-2

% Open Area*	
4" cc	73%
2" cc	67%

ALUMINUM FLUSH TOP

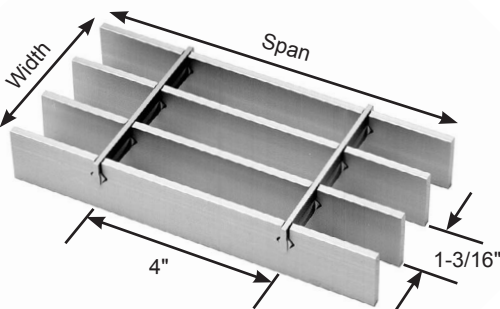

19-SGF-4

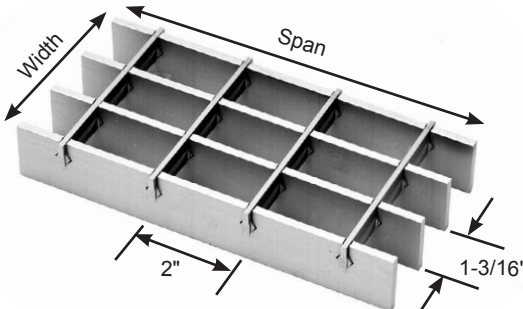

19-SGF-2

% Open Area*		
Bars	1/8"	3/16"
4" cc	85%	80%
2" cc	81%	77%

ALUMINUM DOVE TAIL

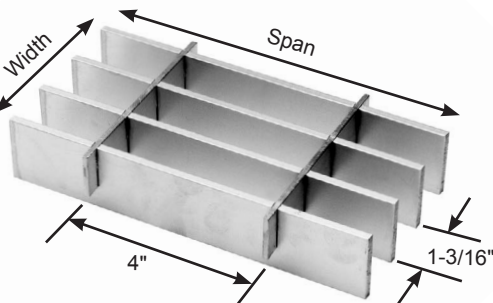

19-ADT-4

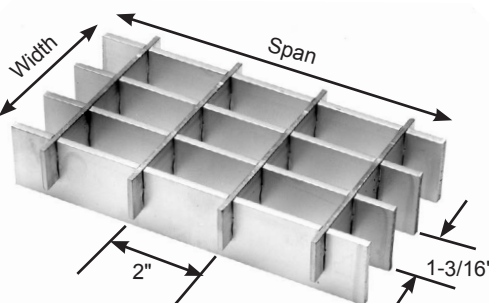

19-ADT-2

% Open Area*		
Bars	1/8"	3/16"
4" cc	86%	81%
2" cc	84%	79%

19 SPACE LOAD TABLES

Bar Size, Inches	Ped Span, Inches	Wt.* Lbs. Sq. Ft.	Sec. Prop Sx*, in ³ / lx*, in ⁴	Clear Span															
				2'- 0"	2'- 6"	3'- 0"	3'- 6"	4'- 0"	4'- 6"	5'- 0"	5'- 6"	6'- 0"	6'- 6"	7'- 0"	8'- 0"				
1 x 1/8	39	1.71	0.211	U	421	269	187	137											
				D	0.144	0.225	0.324	0.439											
			0.105	C	421	337	281	241											
				D	0.115	0.180	0.259	0.353											
1 x 3/16	44	2.46	0.316	U	632	404	281	206	158										
				D	0.144	0.225	0.324	0.441	0.576										
		I-Bar	1.99	0.158	C	632	505	421	361	316									
					D	0.115	0.180	0.259	0.353	0.461									
1-1/4 x 1/8	47	2.08	0.329	U	658	421	292	215	164										
				D	0.115	0.180	0.259	0.353	0.459										
		0.206	C	658	526	439	376	329											
			D	0.092	0.144	0.208	0.282	0.369											
1-1/4 x 3/16	52	3.01	0.493	U	987	632	439	322	247	195									
				D	0.115	0.180	0.259	0.353	0.461	0.583									
		I-Bar	2.34	0.308	C	987	789	658	564	493	439								
					D	0.092	0.144	0.207	0.282	0.368	0.467								
1-1/2 x 1/8	53	2.46	0.474	U	947	606	421	309	237	187									
				D	0.096	0.150	0.216	0.294	0.384	0.486									
		0.355	C	947	758	632	541	474	421										
			D	0.077	0.120	0.173	0.235	0.307	0.389										
1-1/2 x 3/16	59	3.56	0.711	U	1421	909	632	464	355	281	227								
				D	0.096	0.150	0.216	0.294	0.384	0.487	0.599								
		I-Bar	2.70	0.533	C	1421	1137	947	812	711	632	568							
					D	0.077	0.120	0.173	0.235	0.307	0.389	0.480							
1-3/4 x 3/16	66	4.12	0.967	U	1934	1238	860	632	484	382	309	256	215						
				D	0.082	0.129	0.185	0.252	0.329	0.417	0.514	0.623	0.741						
		I-Bar	3.06	0.846	C	1934	1547	1289	1105	967	860	774	703	645					
					D	0.066	0.103	0.148	0.202	0.263	0.333	0.412	0.498	0.593					
2 x 3/16	73	4.68	1.263	U	2526	1617	1123	825	632	499	404	334	281	239					
				D	0.072	0.113	0.162	0.221	0.288	0.364	0.450	0.544	0.649	0.760					
		I-Bar	3.43	1.263	C	2526	2021	1684	1444	1263	1123	1011	919	842	777				
					D	0.058	0.090	0.130	0.176	0.230	0.292	0.360	0.436	0.518	0.608				
2-1/4 x 3/16	80	5.24	1.599	U	3197	2046	1421	1044	799	632	512	423	355	303	261				
				D	0.064	0.100	0.144	0.196	0.256	0.324	0.400	0.484	0.576	0.677	0.784				
		I-Bar	3.75	1.798	C	3197	2558	2132	1827	1599	1421	1279	1163	1066	984	914			
					D	0.051	0.080	0.115	0.157	0.205	0.259	0.320	0.387	0.461	0.541	0.628			
2-1/2 x 3/16	87	5.79	1.974	U	3947	2526	1754	1289	987	780	632	522	439	374	322	247			
				D	0.058	0.090	0.130	0.176	0.230	0.292	0.360	0.436	0.519	0.609	0.705	0.823			
		I-Bar	4.15	2.467	C	3947	3158	2632	2256	1974	1754	1579	1435	1316	1215	1128	987		
					D	0.046	0.072	0.104	0.141	0.184	0.233	0.288	0.348	0.415	0.487	0.565	0.737		

U - Safe uniform load in pounds/sq. ft.
 C - Safe concentrated load in pounds/ft. grating width
 D - Deflection in inches

Loads and deflections given in this table are theoretical, and are based on a unit stress of 12,000 psi.

*Based on 10.105 bars/ft. of grating width. Bearing bars 1-3/16" c.c. Add .3 lbs./sq. ft. for 19-SG-2. **Note:** Grating for spans to the left of the heavy line has a deflection less than 1/4" for uniform loads of 100 lbs./sq. ft. This is the maximum deflection to afford pedestrian comfort and can be exceeded for other types of load at the discretion of the engineer. The actual Ped (pedestrian) Span under this condition is shown above for each size of grating. When serrated grating is specified, the depth of grating required for a specific load will be 1/4" greater than that shown in these tables.

Panel Width Chart (in.) - 19-SG-4, 19-SG-2, 19-SGLi-4, 19-SGLi-2, 19-SGF-4, 19-SGF-2, 19-ADT-4 & 19-ADT-2
Dimensions Are Out-to-Out of Bearing Bars**

No. of Bars	2	3	4	5	6	7	8	9	10	11	12	13	14	15	16
3/16" Bars	1-3/8	2-9/16	3-3/4	4-15/16	6-1/8	7-5/16	8-1/2	9-11/16	10-7/8	12-1/16	13-1/4	14-7/16	15-5/8	16-13/16	18
No. of Bars	17	18	19	20	21	22	23	24	25	26	27	28	29	30	31
3/16" Bars	19-3/16	20-3/8	21-9/16	22-3/4	23-15/16	25-1/8	26-5/16	27-1/2	28-11/16	29-7/8	31-1/16	32-1/4	33-7/16	34-5/8	35-13/16

**Add 1/4" for extended cross bars. Deduct 1/16" for 1/8" bearing bars. Standard panel widths indicated in teal.

Panel Width Chart (in.) - 19-SGI-4 & 19-SGI-2
Dimensions Are Out-to-Out of Bearing Bars**

No. of Bars	2	3	4	5	6	7	8	9	10	11	12	13	14	15	16
1/4" Flange	1-7/16	2-5/8	3-13/16	5	6-3/16	7-3/8	8-9/16	9-3/4	10-15/16	12-1/8	13-5/16	14-1/2	15-11/16	16-7/8	18-1/16
No. of Bars	17	18	19	20	21	22	23	24	25	26	27	28	29	30	31
1/4" Flange	19-1/4	20-7/16	21-5/8	22-13/16	24	25-3/16	26-3/8	27-9/16	28-3/4	29-15/16	31-1/8	32-5/16	33-1/2	34-11/16	35-7/8

**Bar thickness is 1/4" at top and bottom. Add 1/4" for extended cross bars. Standard panel widths indicated in teal.

15 SPACE PROFILES

ALUMINUM RECTANGULAR BAR

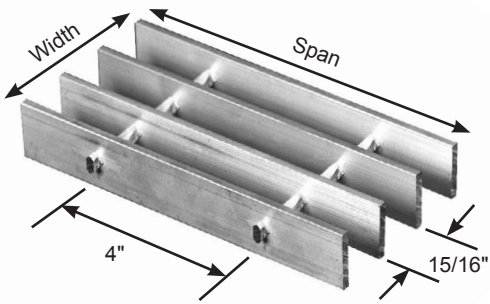

15-SG-4

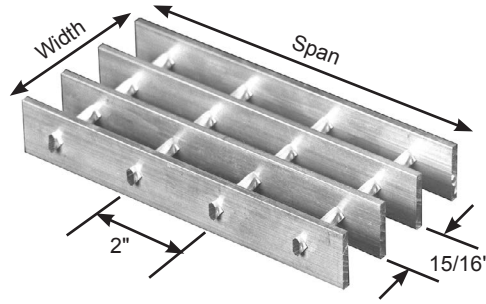

15-SG-2

% Open Area*	
4" CC	76%
2" CC	73%

ALUMINUM I-BAR

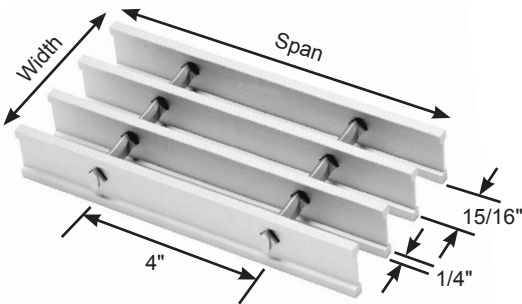

15-SGI-4

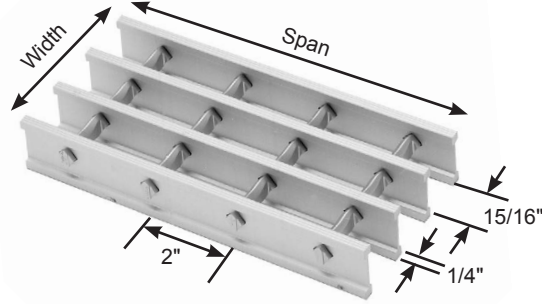

15-SGI-2

% Open Area*	
4" CC	68%
2" CC	62%

ALUMINUM FLUSH TOP

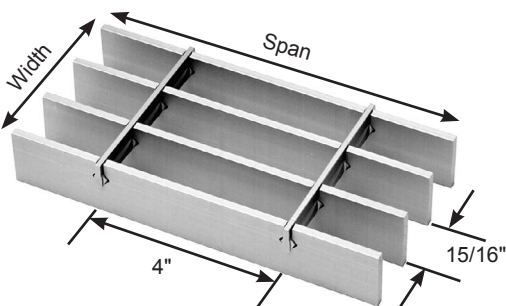

15-SGF-4

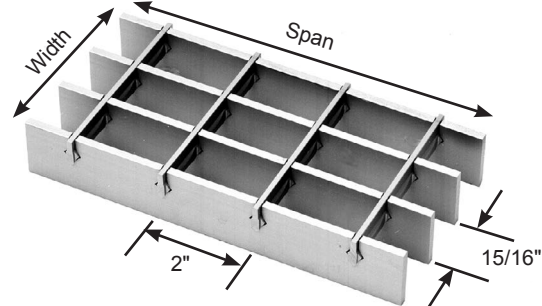

15-SGF-2

% Open Area*	
4" CC	76%
2" CC	73%

ALUMINUM DOVE TAIL

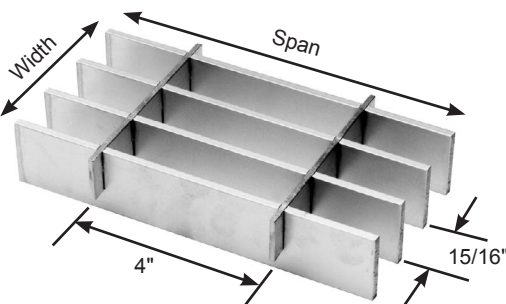

15-ADT-4

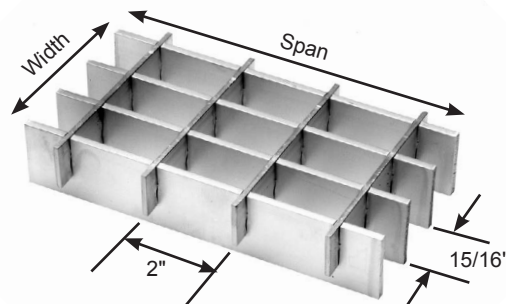

15-ADT-2

% Open Area*	
4" CC	77%
2" CC	75%

15 SPACE LOAD TABLES

Bar Size, Inches	Ped Span, Inches	Wt.* Lbs. Sq. Ft.	Sec. Prop Sx*, in ³ Ix*, in ⁴	ClearSpan												
				2'- 0"	2'- 6"	3'- 0"	3'- 6"	4'- 0"	4'- 6"	5'- 0"	5'- 6"	6'- 0"	6'- 6"	7'- 0"	8'- 0"	
1 x 3/16	46	3.06	0.400	U	800	512	356	261	200							
				D	0.144	0.225	0.324	0.441	0.576							
I-Bar		2.42	0.200	C	800	640	533	457	400							
				D	0.115	0.180	0.259	0.353	0.461							
1-1/4 x 3/16	55	3.75	0.625	U	1250	800	556	408	313	247	200					
				D	0.115	0.180	0.259	0.353	0.462	0.583	0.720					
I-Bar		2.87	0.391	C	1250	1000	833	714	625	556	500					
				D	0.092	0.144	0.207	0.282	0.369	0.467	0.576					
1-1/2 x 3/16	63	4.45	0.900	U	1800	1152	800	588	450	356	288	238				
				D	0.096	0.150	0.216	0.294	0.384	0.487	0.600	0.726				
I-Bar		3.33	0.675	C	1800	1440	1200	1029	900	800	720	655				
				D	0.077	0.120	0.173	0.235	0.307	0.389	0.480	0.581				
1-3/4 x 3/16	70	5.16	1.225	U	2450	1568	1089	800	613	484	392	324	272			
				D	0.082	0.129	0.185	0.252	0.329	0.417	0.514	0.622	0.740			
I-Bar		3.78	1.072	C	2450	1960	1633	1400	1225	1089	980	891	817			
				D	0.066	0.103	0.148	0.202	0.263	0.333	0.411	0.498	0.593			
2 x 3/16	78	5.87	1.600	U	3200	2048	1422	1045	800	632	512	423	356	303	261	
				D	0.072	0.113	0.162	0.221	0.288	0.364	0.450	0.544	0.649	0.761	0.881	
I-Bar		4.25	1.600	C	3200	2560	2133	1829	1600	1422	1280	1164	1067	985	914	
				D	0.058	0.090	0.130	0.176	0.230	0.292	0.360	0.436	0.519	0.609	0.705	
2-1/4 x 3/16	85	6.57	2.025	U	4050	2592	1800	1322	1013	800	648	536	450	383	331	253
				D	0.064	0.100	0.144	0.196	0.256	0.324	0.400	0.484	0.576	0.675	0.785	1.023
I-Bar		4.66	2.278	C	4050	3240	2700	2314	2025	1800	1620	1473	1350	1246	1157	1013
				D	0.051	0.080	0.115	0.157	0.205	0.259	0.320	0.387	0.461	0.541	0.627	0.820
2-1/2 x 3/16	92	7.27	2.500	U	5000	3200	2222	1633	1250	988	800	661	556	473	408	313
				D	0.058	0.090	0.130	0.176	0.230	0.292	0.360	0.435	0.519	0.608	0.705	0.923
I-Bar		5.16	3.125	C	5000	4000	3333	2857	2500	2222	2000	1818	1667	1538	1429	1250
				D	0.046	0.072	0.104	0.141	0.184	0.233	0.288	0.348	0.415	0.487	0.565	0.737

*Based on 12.8 bars/ft. of grating width. Bearing bars 15/16" c.c. Add 3 lbs./sq. ft. for 15-SG-2, 1/8" bearing bars available by inquiry. Note: Grating for spans to the left of the heavy line have a deflection less than 1/4" for uniform loads of 100 lbs./sq. ft. This is the maximum deflection to afford pedestrian comfort and can be exceeded for other types of load at the discretion of the engineer. The actual Ped (pedestrian) Span under this condition is shown above for each size of grating. When serrated grating is specified, the depth of grating required for a specific load will be 1/4" greater than that shown in these tables.

Panel Width Chart (in.) - 15-SG-4, 15-SG-2, 15-SGLi-4, 15-SGLi-2, 15-SGF-4, 15-SGF-2, 15-ADT-4 & 15-ADT-2 Dimensions Are Out-to-Out of Bearing Bars**

No. of Bars	2	3	4	5	6	7	8	9	10	11	12	13	14	15	16
3/16" Bars	1-1/8	2-1/16	3	3-15/16	4-7/8	5-13/16	6-3/4	7-11/16	8-5/8	9-9/16	10-1/2	11-7/16	12-3/8	13-5/16	14-1/4
No. of Bars	17	18	19	20	21	22	23	24	25	26	27	28	29	30	31
3/16" Bars	15-3/16	16-1/8	17-1/16	18	18-15/16	19-7/8	20-13/16	21-3/4	22-11/16	23-5/8	24-9/16	25-1/2	26-7/16	27-3/8	28-5/16
No. of Bars	32	33	34	35	36	37	38	39							
3/16" Bars	29-1/4	30-3/16	31-1/8	32-1/16	33	33-15/16	34-7/8	35-13/16							

**Add 1/4" for extended cross bars. Deduct 1/16" for 1/8" bearing bars. Standard panel widths indicated in teal.

Panel Width Chart (in.) - 15-SGI-4 & 15-SGI-2 Dimensions Are Out-to-Out of Bearing Bars**

No. of Bars	2	3	4	5	6	7	8	9	10	11	12	13	14	15	16
1/4" Flange	1-3/16	2-1/8	3-1/16	4	4-15/16	5-7/8	6-13/16	7-3/4	8-11/16	9-5/8	10-9/16	11-1/2	12-7/16	13-3/8	14-5/16
No. of Bars	17	18	19	20	21	22	23	24	25	26	27	28	29	30	31
1/4" Flange	15-1/4	16-3/16	17-1/8	18-1/16	19	19-15/16	20-7/8	21-13/16	22-3/4	23-11/16	24-5/8	25-9/16	26-1/2	27-7/16	28-3/8
No. of Bars	32	33	34	35	36	37	38	39							
1/4" Flange	29-1/4	30-1/4	31-3/16	32-1/8	33-1/16	34	34-15/16	35-7/8							

**Bar thickness is 1/4" at top and bottom. Add 1/4" for extended cross bars. Standard panel widths indicated in teal.

11 SPACE PROFILES Products conform to ADA specifications

ALUMINUM RECTANGULAR BAR

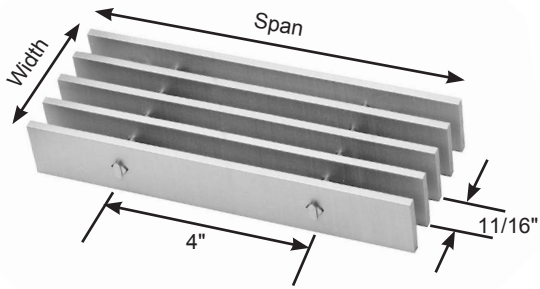

11-SG-4

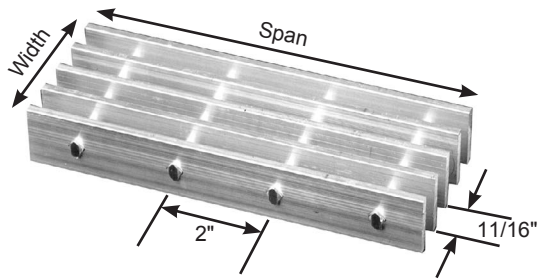

11-SG-2

% Open Area*	
4" cc	69%
2" cc	66%

ALUMINUM I-BAR

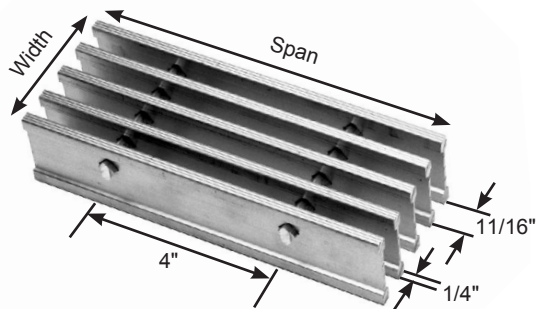

11-SGI-4

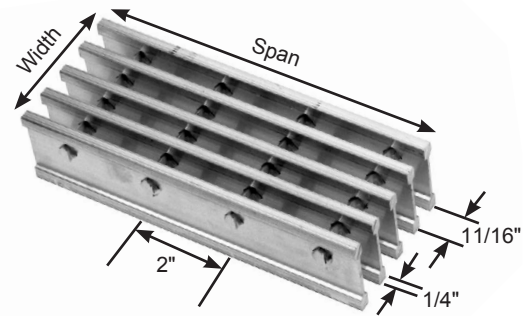

11-SGI-2

% Open Area*	
4" cc	59%
2" cc	55%

ALUMINUM FLUSH TOP

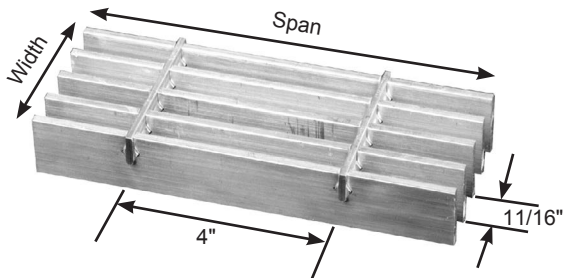

11-SGF-4

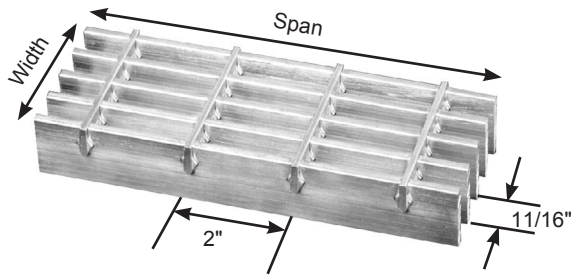

11-SGF-2

% Open Area*	
4" cc	69%
2" cc	66%

ALUMINUM DOVE TAIL

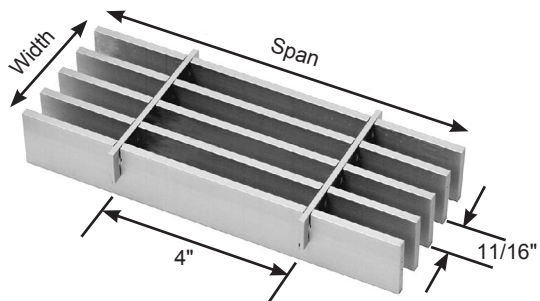

11-ADT-4

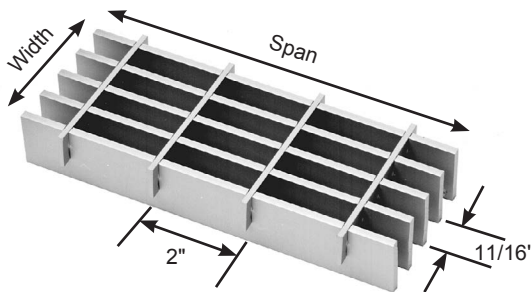

11-ADT-2

% Open Area*	
4" cc	70%
2" cc	68%

11 SPACE LOAD TABLES

Bar Size, Inches	Ped Span, Inches	Wt.* Lbs. Sq. Ft.	Sec. Prop Sx*, in ³ lx*, in ⁴	Clear Span																								
				2'- 0"	2'- 6"	3'- 0"	3'- 6"	4'- 0"	4'- 6"	5'- 0"	5'- 6"	6'- 0"	6'- 6"	7'- 0"	8'- 0"													
1 x 3/16 I-Bar	50	4.13	0.545	U	1091	698	485	356	273	215	U - Safe uniform load in pounds/sq. ft. C - Safe concentrated load in pounds/ft. grating width D - Deflection in inches Loads and deflections given in this table are theoretical, and are based on a unit stress of 12,000 psi.																	
				D	0.144	0.225	0.324	0.441	0.577	0.727																		
		3.18	0.273	C	1091	873	727	623	545	485																		
				D	0.115	0.180	0.259	0.353	0.460	0.583																		
1-1/4 x 3/16 I-Bar	59	5.13	0.852	U	1705	1091	758	557	426	337							273	U - Safe uniform load in pounds/sq. ft. C - Safe concentrated load in pounds/ft. grating width D - Deflection in inches Loads and deflections given in this table are theoretical, and are based on a unit stress of 12,000 psi.										
				D	0.115	0.180	0.259	0.353	0.461	0.584							0.721											
		3.79	0.533	C	1705	1364	1136	974	852	758							682											
				D	0.092	0.144	0.207	0.282	0.369	0.467							0.576											
1-1/2 x 3/16 I-Bar	68	6.21	1.227	U	2455	1571	1091	802	614	485	393	325	273	U - Safe uniform load in pounds/sq. ft. C - Safe concentrated load in pounds/ft. grating width D - Deflection in inches Loads and deflections given in this table are theoretical, and are based on a unit stress of 12,000 psi.														
				D	0.096	0.150	0.216	0.294	0.384	0.486	0.600	0.727	0.865															
		4.42	0.920	C	2455	1964	1636	1403	1227	1091	982	893	818															
				D	0.077	0.120	0.173	0.235	0.307	0.389	0.480	0.581	0.691															
1-3/4 x 3/16 I-Bar	76	7.18	1.670	U	3341	2138	1485	1091	835	660	535	442	371							316	U - Safe uniform load in pounds/sq. ft. C - Safe concentrated load in pounds/ft. grating width D - Deflection in inches Loads and deflections given in this table are theoretical, and are based on a unit stress of 12,000 psi.							
				D	0.082	0.129	0.185	0.252	0.329	0.417	0.515	0.623	0.740							0.868								
		5.03	1.462	C	3341	2673	2227	1909	1670	1485	1336	1215	1114							1028								
				D	0.066	0.103	0.148	0.202	0.263	0.333	0.411	0.498	0.593							0.695								
2 x 3/16 I-Bar	84	8.14	2.182	U	4364	2793	1939	1425	1091	862	698	577	485	413	356	273	U - Safe uniform load in pounds/sq. ft. C - Safe concentrated load in pounds/ft. grating width D - Deflection in inches Loads and deflections given in this table are theoretical, and are based on a unit stress of 12,000 psi.											
				D	0.072	0.113	0.162	0.221	0.288	0.365	0.450	0.544	0.648	0.760	0.881	1.153												
		5.67	2.182	C	4364	3491	2909	2494	2182	1939	1746	1587	1455	1343	1247	1091												
				D	0.058	0.090	0.130	0.176	0.230	0.292	0.360	0.436	0.519	0.609	0.706	0.922												
2-1/4 x 3/16 I-Bar	92	9.10	2.761	U	5523	3535	2455	1803	1381	1091	884	730	614	523	451	345							U - Safe uniform load in pounds/sq. ft. C - Safe concentrated load in pounds/ft. grating width D - Deflection in inches Loads and deflections given in this table are theoretical, and are based on a unit stress of 12,000 psi.					
				D	0.064	0.100	0.144	0.196	0.256	0.324	0.400	0.484	0.576	0.676	0.784	1.023												
		6.23	3.107	C	5523	4418	3682	3156	2761	2455	2209	2008	1841	1699	1578	1381												
				D	0.051	0.080	0.115	0.157	0.205	0.259	0.320	0.387	0.461	0.541	0.627	0.819												
2-1/2 x 3/16 I-Bar	100	10.06	3.409	U	6818	4364	3030	2226	1705	1347	1091	902	758	646	557	426	U - Safe uniform load in pounds/sq. ft. C - Safe concentrated load in pounds/ft. grating width D - Deflection in inches Loads and deflections given in this table are theoretical, and are based on a unit stress of 12,000 psi.											
				D	0.058	0.090	0.130	0.176	0.230	0.292	0.360	0.436	0.519	0.609	0.706	0.921												
		6.91	4.261	C	6818	5455	4546	3896	3409	3030	2727	2479	2273	2098	1948	1705												
				D	0.046	0.072	0.104	0.141	0.184	0.233	0.288	0.348	0.415	0.487	0.564	0.737												

*Based on 17.455 bars/ft. of grating width. Bearing bars 11/16" c.c. Add .4 lbs./sq. ft. for 11-SGF-2, 1/8" bearing bars available by inquiry. Note: Grating for spans to the left of the heavy line have a deflection less than 1/4" for uniform loads of 100 lbs./sq. ft. This is the maximum deflection to afford pedestrian comfort and can be exceeded for other types of load at the discretion of the engineer. The actual Ped (pedestrian) Span under this condition is shown above for each size of grating. When serrated grating is specified, the depth of grating required for a specific load will be 1/4" greater than that shown in these tables.

Panel Width Chart (in.) - 11-SGF-4, 11-SGF-2, 11-SGLi-4, 11-SGLi-2, 11-SG-4, 11-SG-2, 11-ADT-4 & 11-ADT-2
 Dimensions Are Out-to-Out of Bearing Bars**

No. of Bars	2	3	4	5	6	7	8	9	10	11	12	13	14	15	16
3/16" Bars	7/8	1-9/16	2-1/4	2-5/16	3-5/8	4-5/16	5	5-11/16	6-3/8	7-1/16	7-3/4	8-7/16	9-1/8	9-13/16	10-1/2
No. of Bars	17	18	19	20	21	22	23	24	25	26	27	28	29	30	31
3/16" Bars	11-3/16	11-7/8	12-9/16	13-1/4	13-15/16	14-5/8	15-5/16	16	16-11/16	17-3/8	18-1/16	18-3/4	19-7/16	20-1/8	20-13/16
No. of Bars	32	33	34	35	36	37	38	39	40	41	42	43	44	45	46
3/16" Bars	21-1/2	22-3/16	22-7/8	23-9/16	24-1/4	24-15/16	25-5/8	26-5/16	27	27-11/16	28-3/8	29-1/16	29-3/4	30-7/16	31-1/8
No. of Bars	47	48	49	50	51	52	53								
3/16" Bars	31-13/16	32-1/2	33-3/16	33-7/8	34-9/16	35-1/4	35-15/16								

**Add 1/4" for extended cross bars. Deduct 1/16" for 1/8" bearing bars. Standard panel widths indicated in teal.

Panel Width Chart (in.) - 11-SGI-4 & 11-SGI-2 Dimensions Are Out-to-Out of Bearing Bars**

No. of Bars	2	3	4	5	6	7	8	9	10	11	12	13	14	15	16
1/4" Flange	15/16	1-5/8	2-5/16	3	3-11/16	4-3/8	5-1/16	5-3/4	6-7/16	7-1/8	7-13/16	8-1/2	9-3/16	9-7/8	10-9/16
No. of Bars	17	18	19	20	21	22	23	24	25	26	27	28	29	30	31
1/4" Flange	11-1/4	11-15/16	12-5/8	13-5/16	14	14-11/16	15-3/8	16-1/16	16-3/4	17-7/16	18-1/8	18-13/16	19-1/2	20-3/16	20-7/8
No. of Bars	32	33	34	35	36	37	38	39	40	41	42	43	44	45	46
1/4" Flange	21-9/16	22-1/4	22-15/16	23-5/8	24-5/16	25	25-11/16	26-3/8	27-1/16	27-3/4	28-7/16	29-1/8	29-13/16	30-1/2	31-3/16
No. of Bars	47	48	49	50	51	52	53								
1/4" Flange	31-7/8	32-9/16	33-1/4	33-15/16	34-5/8	35-5/16	36								

**Bar thickness is 1/4" at top and bottom. Add 1/4" for extended cross bars. Standard panel widths indicated in teal.

7 SPACE PROFILES

Products conform to ADA specifications

ALUMINUM RECTANGULAR BAR

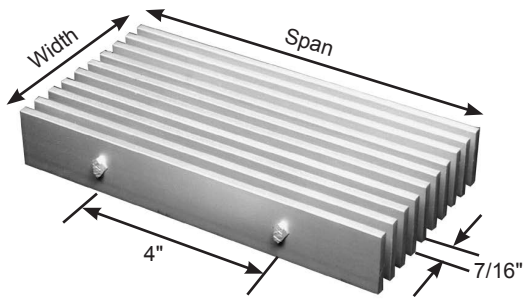

7-SG-4

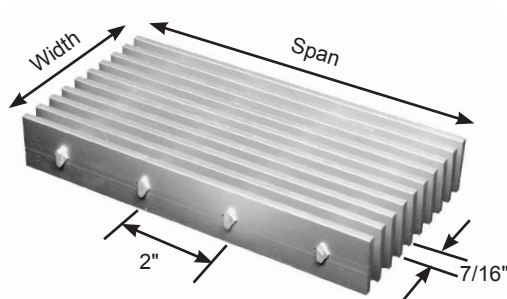

7-SG-2

% Open Area*	
4" cc	54%
2" cc	51%

ALUMINUM I-BAR

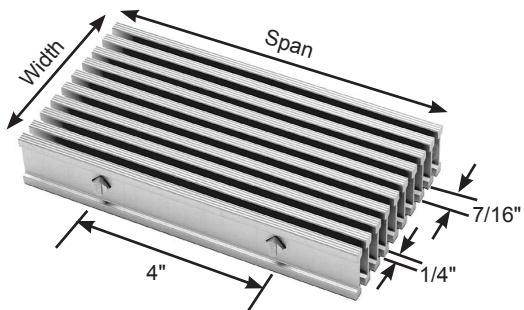

7-SGI-4

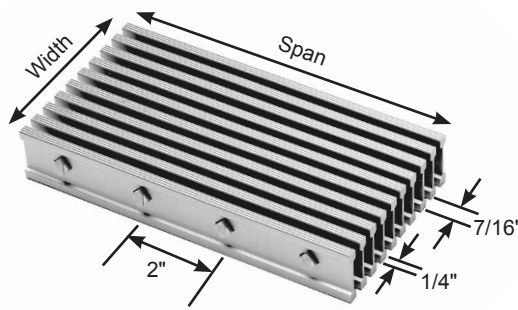

7-SGI-2

% Open Area*	
4" cc	39%
2" cc	36%

ALUMINUM FLUSH TOP

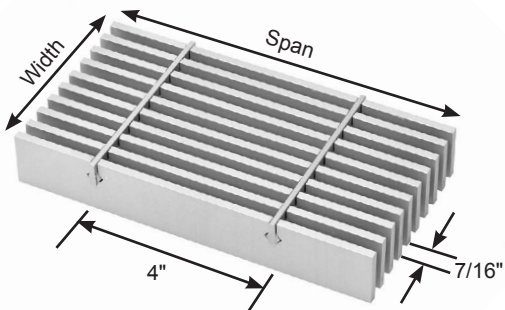

7-SGF-4

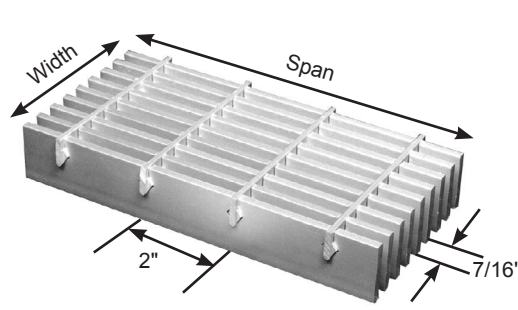

7-SGF-2

% Open Area*	
4" cc	54%
2" cc	51%

ALUMINUM DOVE TAIL

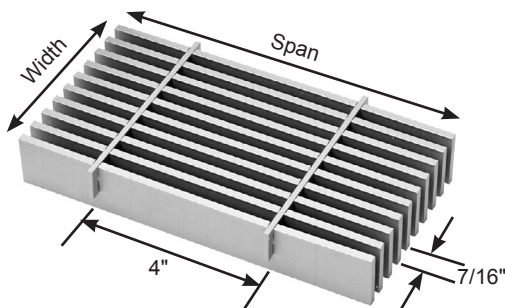

7-ADT-4

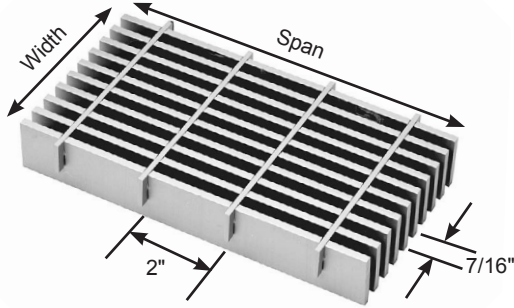

7-ADT-2

% Open Area*	
4" cc	55%
2" cc	53%

7 SPACE LOAD TABLES

Bar Size, Inches	Ped Span, Inches	Wt.* Lbs. Sq. Ft.	Sec. Prop Sx*, in ³ lx*, in ⁴	ClearSpan												
				2'- 0"	2'- 6"	3'- 0"	3'- 6"	4'- 0"	4'- 6"	5'- 0"	5'- 6"	6'- 0"	6'- 6"	7'- 0"	8'- 0"	
1 x 3/16 I-Bar	56	6.30	0.857	U	1714	1097	762	560	429	339	274	U - Safe uniform load in pounds/sq. ft. C - Safe concentrated load in pounds/ft. grating width D - Deflection in inches Loads and deflections given in this table are theoretical, and are based on a unit stress of 12,000 psi.				
				D	0.144	0.225	0.324	0.441	0.577	0.730	0.899					
		C	1714	1371	1143	980	857	762	686	298						
		D	0.115	0.180	0.259	0.353	0.461	0.583	0.720	0.830						
1-1/4 x 3/16 I-Bar	66	7.78	1.339	U	2679	1714	1190	875	670	529	429	354	298	U - Safe uniform load in pounds/sq. ft. C - Safe concentrated load in pounds/ft. grating width D - Deflection in inches Loads and deflections given in this table are theoretical, and are based on a unit stress of 12,000 psi.		
				D	0.115	0.180	0.259	0.353	0.461	0.583	0.721	0.871	1.038			
		C	2679	2143	1786	1531	1339	1190	1071	974	893	893				
		D	0.092	0.144	0.207	0.282	0.369	0.466	0.576	0.697	0.830	0.830				
1-1/2 x 3/16 I-Bar	76	9.28	1.929	U	3857	2469	1714	1259	964	762	617	510	429	365	U - Safe uniform load in pounds/sq. ft. C - Safe concentrated load in pounds/ft. grating width D - Deflection in inches Loads and deflections given in this table are theoretical, and are based on a unit stress of 12,000 psi.	
				D	0.096	0.150	0.216	0.294	0.384	0.486	0.600	0.726	0.865	1.014		
		C	3857	3086	2571	2204	1929	1714	1543	1403	1286	1187	1187			
		D	0.077	0.120	0.173	0.235	0.307	0.389	0.480	0.581	0.691	0.811	0.811			
1-3/4 x 3/16 I-Bar	85	10.80	2.625	U	5250	3360	2333	1714	1313	1037	840	694	583	497	429	328
				D	0.082	0.129	0.185	0.252	0.329	0.417	0.514	0.622	0.740	0.869	1.009	1.316
		C	5250	4200	3500	3000	2625	2333	2100	1909	1750	1615	1500	1313	1313	
		D	0.066	0.103	0.148	0.202	0.263	0.333	0.411	0.498	0.592	0.695	0.806	1.054	1.054	
2 x 3/16 I-Bar	94	12.32	3.429	U	6857	4389	3048	2239	1714	1355	1097	907	762	649	560	429
				D	0.072	0.113	0.162	0.220	0.288	0.365	0.450	0.545	0.648	0.760	0.882	1.153
		C	6857	5486	4572	3918	3429	3048	2743	2494	2286	2110	1959	1714	1714	
		D	0.058	0.090	0.130	0.176	0.230	0.292	0.360	0.436	0.518	0.608	0.706	0.921	0.921	
2-1/4 x 3/16 I-Bar	103	13.83	4.339	U	8679	5554	3857	2834	2170	1714	1389	1148	964	822	708	542
				D	0.064	0.100	0.144	0.196	0.256	0.324	0.400	0.484	0.576	0.676	0.783	1.023
		C	8679	6943	5786	4959	4339	3857	3471	3156	2893	2670	2480	2170	2170	
		D	0.051	0.080	0.115	0.157	0.205	0.259	0.320	0.387	0.461	0.541	0.627	0.819	0.819	
2-1/2 x 3/16 I-Bar	111	15.33	5.357	U	10714	6857	4762	3499	2679	2116	1714	1417	1190	1014	875	670
				D	0.058	0.090	0.130	0.176	0.230	0.292	0.360	0.436	0.518	0.608	0.706	0.922
		C	10714	8572	7143	6123	5357	4762	4286	3896	3571	3297	3061	2679	2679	
		D	0.046	0.072	0.104	0.141	0.184	0.233	0.288	0.348	0.415	0.487	0.564	0.737	0.737	

*Based on 27.429 bars/ft. of grating width. Bearing bars 7/16" c.c. Add .3 lbs./sq. ft. for 7-SG-2. 1/8" bearing bars available by inquiry. Note: Grating for spans to the left of the heavy line have a deflection less than 1/4" for uniform loads of 100 lbs./sq. ft. This is the maximum deflection to afford pedestrian comfort and can be exceeded for other types of load at the discretion of the engineer. The actual Ped (pedestrian) Span under this condition is shown above for each size of grating. When serrated grating is specified, the depth of grating required for a specific load will be 1/4" greater than that shown in these tables.

Panel Width Chart (in.) - 7-SG-4, 7-SG-2, 7-SGLi-4, 7-SGLi-2, 7-SGF-4, 7-SGF-2, 7-ADT-4 & 7-ADT-2 Dimensions Are Out-to-Out of Bearing Bars**

No. of Bars	2	3	4	5	6	7	8	9	10	11	12	13	14	15	16
3/16" Bars	5/8	1-1/16	1-1/2	1-15/16	2-3/8	2-13/16	3-1/4	3-11/16	4-1/8	4-9/16	5	5-7/16	5-7/8	6-5/16	6-3/4
No. of Bars	17	18	19	20	21	22	23	24	25	26	27	28	29	30	31
3/16" Bars	7-3/16	7-5/8	8-1/16	8-1/2	8-15/16	9-3/8	9-13/16	10-1/4	10-11/16	11-1/8	11-9/16	12	12-7/16	12-7/8	13-5/16
No. of Bars	32	33	34	35	36	37	38	39	40	41	42	43	44	45	46
3/16" Bars	13-3/4	14-3/16	14-5/8	15-1/16	15-1/2	15-15/16	16-3/8	16-13/16	17-1/4	17-11/16	18-1/8	18-9/16	19	19-7/16	19-7/8
No. of Bars	47	48	49	50	51	52	53	54	55	56	57	58	59	60	61
3/16" Bars	20-5/16	20-3/4	21-3/16	21-5/8	22-1/16	22-1/2	22-15/16	23-3/8	23-13/16	24-1/4	24-11/16	25-1/8	25-9/16	26	26-7/16
No. of Bars	62	63	64	65	66	67	68	69	70	71	72	73	74	75	76
3/16" Bars	26-7/8	27-5/16	27-3/4	28-3/16	28-5/8	29-1/16	29-1/2	29-15/16	30-3/8	30-13/16	31-1/4	31-11/16	32-1/8	32-9/16	33
No. of Bars	77	78	79	80	81	82	83								
3/16" Bars	33-7/16	33-7/8	34-5/16	34-3/4	35-3/16	35-5/8	36-1/16								

**Add 1/4" for extended cross bars. Deduct 1/16" for 1/8" bearing bars. Standard panel widths indicated in teal.

Panel Width Chart (in.) - 7-SGI-4 & 7-SGI-2 Dimensions Are Out-to-Out of Bearing Bars**

No. of Bars	2	3	4	5	6	7	8	9	10	11	12	13	14	15	16
1/4" Flange	11/16	1-1/8	1-9/16	2	2-7/16	2-7/8	3-5/16	3-3/4	4-3/16	4-5/8	5-1/16	5-1/2	5-15/16	6-3/8	6-13/16
No. of Bars	17	18	19	20	21	22	23	24	25	26	27	28	29	30	31
1/4" Flange	7-1/4	7-11/16	8-1/8	8-9/16	9	9-7/16	9-7/8	10-5/16	10-3/4	11-3/16	11-5/8	12-1/16	12-1/2	12-15/16	13-3/8
No. of Bars	32	33	34	35	36	37	38	39	40	41	42	43	44	45	46
1/4" Flange	13-13/16	14-1/4	14-11/16	15-1/8	15-9/16	16	16-7/16	16-7/8	17-5/16	17-3/4	18-3/16	18-5/8	19-1/16	19-1/2	19-15/16
No. of Bars	47	48	49	50	51	52	53	54	55	56	57	58	59	60	61
1/4" Flange	20-3/8	20-13/16	21-1/4	21-11/16	22-1/8	22-9/16	23	23-7/16	23-7/8	24-5/16	24-3/4	25-3/16	25-5/8	26-1/16	26-1/2
No. of Bars	62	63	64	65	66	67	68	69	70	71	72	73	74	75	76
1/4" Flange	26-15/16	27-3/8	27-13/16	28-1/4	28-11/16	29-1/8	29-9/16	30	30-7/16	30-7/8	31-5/16	31-3/4	32-3/16	32-5/8	33-1/16
No. of Bars	77	78	79	80	81	82	83								
1/4" Flange	33-1/2	33-15/16	34-3/8	34-13/16	35-1/4	35-11/16	36-1/8								

**Bar thickness is 1/4" at top and bottom. Add 1/4" for extended cross bars. Standard panel widths indicated in teal.



SGLi SERIES

BENEFITS:

- 20% Lighter
- Reduces Freight Cost
- Meets ADA Requirements
- More Economical
- Meets NAAMM Standards
- Easy Field Installation
- OnGrip® Spray Traction Surface is available.

APPLICATIONS:

- Walkways
- Entranceways
- Vents / Air Grilles
- Ceiling Tiles
- Sun Screens
- Material Screens
- Security Screens

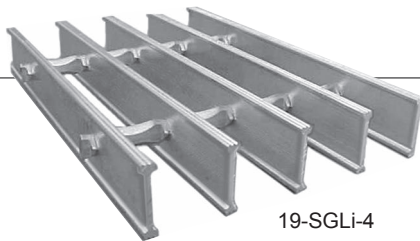

19-SGLi-4

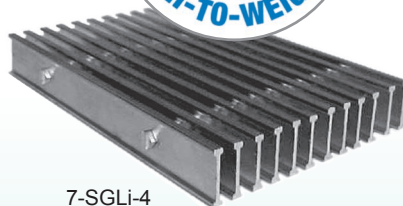

7-SGLi-4

End view ►



GRATING PROFILES AVAILABLE...

SGLi SERIES Aluminum **LiTEBAR**

All profiles shown below are also available with 2" cross bar centers. Product numbers would be 19-SGLi-2, 15-SGLi-2, 11-SGLi-2 and 7-SGLi-2

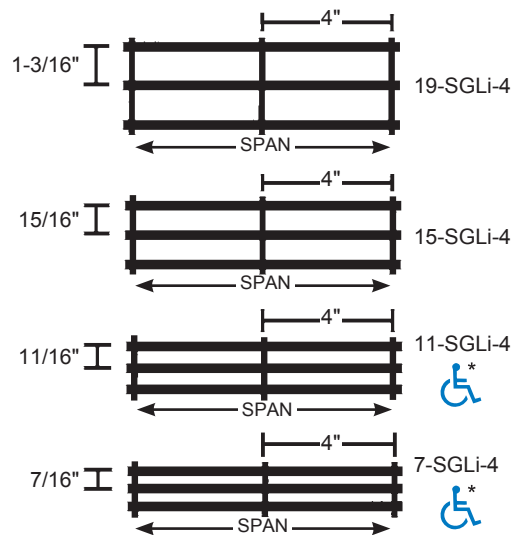

*Note: Conforms with the spacing requirements of ADA (September 2010) when installed with the elongated opening perpendicular to the dominant direction of travel. See ADA Guidelines

19 & 15 SPACE LOAD TABLES

LOAD TABLE for 19-SGLi-4 & 19-SGLi-2

Bar Size, Inches	Ped Span, Inches	Wt.* Lbs. Sq. Ft.	Sec. Prop S _x [*] , in ² I _x [*] , in ⁴	ClearSpan																	
				1'- 0"	1'- 6"	2'- 0"	2'- 6"	3'- 0"	3'- 6"	4'- 0"	4'- 6"	5'- 0"	5'- 6"	6'- 0"	6'- 6"	7'- 0"	8'- 0"				
3/4"	33	1.36	.119	U	952	423	238	152	106	78	60										
				D	.043	.096	.171	.268	.386	.525	.685										
				C	476	317	238	190	159	136	119										
1"	40	1.66	.211	U	1688	750	422	270	188	138	106	83									
				D	.034	.077	.137	.214	.308	.420	.548										
				C	844	563	422	338	281	241	211	188									
1-1/4"	48	1.97	.339	U	2712	1205	678	434	301	221	170	134	108								
				D	.027	.062	.110	.172	.247	.337	.440	.557	.687								
				C	1356	904	678	542	452	387	339	301	271								
1-1/2"	54	2.27	.464	U	3712	1650	928	594	412	303	232	183	148	123							
				D	.023	.052	.092	.144	.207	.282	.368	.466	.575	.696							
				C	1856	1237	928	742	619	530	464	412	371	337							
2"	67	2.95	.845	U	6760	3004	1690	1082	751	552	423	334	270	223	188	160	138	106			
				D	.017	.039	.070	.109	.157	.214	.279	.354	.437	.528	.629	.738	.856	1.118			
				C	3380	2253	1690	1352	1127	966	845	751	676	615	563	520	483	423			
2-1/2"	79	3.59	1.322	U	10577	4701	2644	1692	1175	863	661	522	423	350	294	250	216	165			
				D	.014	.032	.056	.088	.126	.172	.225	.285	.351	.425	.506	.594	.689	0.899			
				C	5288	3526	2644	2115	1763	1511	1322	1175	1058	962	881	814	755	661			
2-1/2"	79	3.59	1.694	U	10577	4701	2644	1692	1175	863	661	522	423	350	294	250	216	165			
				D	.014	.032	.056	.088	.126	.172	.225	.285	.351	.425	.506	.594	.689	0.899			
				C	5288	3526	2644	2115	1763	1511	1322	1175	1058	962	881	814	755	661			
2-1/2"	79	3.59	1.694	U	10577	4701	2644	1692	1175	863	661	522	423	350	294	250	216	165			
				D	.014	.032	.056	.088	.126	.172	.225	.285	.351	.425	.506	.594	.689	0.899			
				C	5288	3526	2644	2115	1763	1511	1322	1175	1058	962	881	814	755	661			

% Open Area	
4" cc	80%
2" cc	77%

See Panel Width Charts on page 13

LOAD TABLE for 15-SGLi-4 & 15-SGLi-2

Bar Size, Inches	Ped Span, Inches	Wt.* Lbs. Sq. Ft.	Sec. Prop S _x [*] , in ² I _x [*] , in ⁴	ClearSpan															
				1'- 0"	1'- 6"	2'- 0"	2'- 6"	3'- 0"	3'- 6"	4'- 0"	4'- 6"	5'- 0"	5'- 6"	6'- 0"	6'- 6"	7'- 0"	8'- 0"		
3/4"	35	1.62	.151	U	1208	537	302	193	134	99	76								
				D	.043	.097	.173	.270	.388	.529	.690								
				C	604	403	302	242	201	173	151								
1"	43	2.00	.268	U	2144	953	536	343	238	175	134	106							
				D	.034	.076	.136	.212	.306	.416	.544	.688							
				C	1072	715	536	429	357	306	268	238							
1-1/4"	50	2.38	.429	U	3432	1525	858	549	381	280	215	169	137						
				D	.027	.062	.110	.171	.246	.335	.438	.555	.685						
				C	1716	1144	858	686	572	490	429	381	343						
1-1/2"	57	2.77	.588	U	4704	2091	1176	753	523	384	294	232	188	156					
				D	.023	.052	.092	.144	.207	.282	.368	.466	.575	.696					
				C	2352	1568	1176	941	784	672	588	523	470	428					
2"	71	3.63	1.070	U	8560	3804	2140	1370	951	699	535	423	342	283	238	203	175	134	
				D	.017	.039	.070	.109	.157	.214	.279	.354	.437	.528	.629	.738	.856	1.118	
				C	4280	2853	2140	1712	1427	1223	1070	951	856	778	713	658	611	535	
2-1/2"	84	4.45	1.675	U	13398	5954	3349	2144	1489	1094	837	662	536	443	372	317	273	209	
				D	.014	.032	.056	.088	.126	.172	.225	.285	.351	.425	.506	.594	.689	.899	
				C	6699	4466	3349	2680	2233	1914	1675	1489	1340	1218	1116	1031	957	837	
2-1/2"	84	4.45	2.145	U	13398	5954	3349	2144	1489	1094	837	662	536	443	372	317	273	209	
				D	.014	.032	.056	.088	.126	.172	.225	.285	.351	.425	.506	.594	.689	.899	
				C	6699	4466	3349	2680	2233	1914	1675	1489	1340	1218	1116	1031	957	837	

% Open Area	
4" cc	76%
2" cc	73%

See Panel Width Charts on page 15

11 & 7 SPACE LOAD TABLES

LOAD TABLE for 11-SGLi-4 & 11-SGLi-2

Bar Size, Inches	Ped Span, Inches	Wt.* Lbs. Sq. Ft.	Sec. Prop Sx*, in ² Ix*, in ⁴	ClearSpan																		
				1'- 0"	1'- 6"	2'- 0"	2'- 6"	3'- 0"	3'- 6"	4'- 0"	4'- 6"	5'- 0"	5'- 6"	6'- 0"	6'- 6"	7'- 0"	8'- 0"					
3/4"	38	2.06	.206	U	1648	732	412	264	183	135	103											
				D	.043	.097	.172	.269	.388	.528	.690											
				C	824	549	412	330	275	235	206											
1"	46	2.58	.365	U	2920	1298	730	467	324	238	183	144	117									
				D	.034	.076	.135	.212	.305	.415	.542	.686	.847									
				C	1460	973	730	584	487	417	365	324	292									
1-1/4"	55	3.11	.585	U	4680	2080	1170	749	520	382	293	231	187	155								
				D	.027	.062	.110	.171	.247	.336	.439	.555	.686	.830								
				C	2340	1560	1170	936	780	669	585	520	468	425								
1-1/2"	62	3.63	.802	U	6416	2852	1604	1027	713	524	401	317	257	212	178	152						
				D	.023	.052	.092	.144	.207	.282	.368	.466	.576	.696	.829	.973						
				C	3208	2139	1604	1283	1069	917	802	713	642	583	535	494						
2"	77	4.81	1.459	U	11672	5188	2918	1868	1297	953	730	576	467	386	324	276	238	182				
				D	.017	.039	.070	.109	.157	.214	.279	.353	.436	.528	.628	.737	.855	1.117				
				C	5836	3891	2918	2334	1945	1667	1459	1297	1167	1061	973	898	834	730				
2-1/2"	91	5.92	2.284	U	18270	8120	4567	2923	2030	1491	1142	902	731	604	507	432	373	285				
				D	.014	.032	.056	.088	.126	.172	.225	.285	.351	.425	.506	.594	.689	.899				
				C	9135	6090	4567	3654	3045	2610	2284	2030	1827	1661	1522	1405	1305	1142				

% Open Area

4" cc 69%

2" cc 66%

See Panel Width Charts on page 17

LOAD TABLE for 7-SGLi-4 & 7-SGLi-2

Bar Size, Inches	Ped Span, Inches	Wt.* Lbs. Sq. Ft.	Sec. Prop Sx*, in ² Ix*, in ⁴	ClearSpan																
				1'- 0"	1'- 6"	2'- 0"	2'- 6"	3'- 0"	3'- 6"	4'- 0"	4'- 6"	5'- 0"	5'- 6"	6'- 0"	6'- 6"	7'- 0"	8'- 0"			
3/4"	42	3.01	.323	U	2588	1150	647	414	288	211	162	128								
				D	.043	.097	.173	.271	.390	.531	.693	.877								
				C	1294	863	647	518	431	370	323	288								
1"	51	3.83	.573	U	4584	2037	1146	733	509	374	287	226	180							
				D	.034	.076	.136	.212	.305	.416	.543	.687	.833							
				C	2292	1528	1146	917	764	655	573	509	450							
1-1/4"	61	4.65	.920	U	7360	3271	1840	1178	818	601	460	363	294	243	204					
				D	.027	.062	.110	.172	.247	.336	.439	.556	.687	.831	.989					
				C	3680	2453	1840	1472	1227	1051	920	818	736	669	613					
1-1/2"	69	5.47	1.261	U	10088	4484	2522	1614	1121	824	631	498	404	333	280	239				
				D	.023	.052	.092	.144	.207	.282	.369	.467	.576	.697	.830	.974				
				C	5044	3363	2522	2018	1681	1441	1261	1121	1009	917	841	776				
2"	86	7.33	2.293	U	18344	8153	4586	2935	2038	1497	1147	906	737	606	510	434	374	287		
				D	.017	.039	.070	.109	.157	.214	.279	.354	.436	.528	.629	.738	.856	1.117		
				C	9172	6115	4586	3669	3057	2621	2293	2038	1834	1668	1529	1411	1310	1147		
2-1/2"	101	9.07	3.589	U	28709	12760	7177	4594	3190	2344	1794	1418	1148	949	797	680	586	449		
				D	.014	.032	.056	.088	.126	.172	.225	.285	.351	.425	.506	.594	.689	.899		
				C	14355	9570	7177	5742	4785	4101	3589	3190	2871	2610	2392	2208	2051	1794		

% Open Area

4" cc 54%

2" cc 51%

See Panel Width Charts on page 19

ALUMINUM RIVETED



AR SERIES



Riveted grating is the oldest style of industrial footwalk, but still the choice of many engineers due to its ruggedness, reliability and durability. This grating is composed of straight bearing bars, and bent connecting bars, which are joined at their contact points by rivets. Since the connecting bars extend continuously between bearing bars along the grating spans, they not only serve to join the bearing bars together, but also contribute to the load carrying capability and lateral stability of the grating panels. This added dimension makes riveted grating an

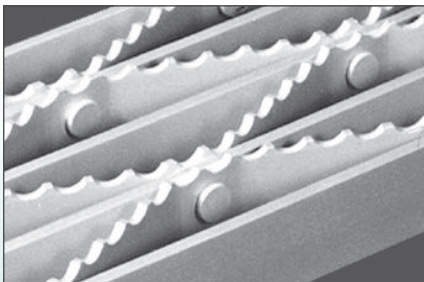

ideal choice where high strength and stiffness are required. OnGrip® Spray Traction Surface is also available.

◀ **Aluminum Riveted Serrated Grating also available**

GRATING PROFILES AVAILABLE...

AR SERIES Aluminum Riveted

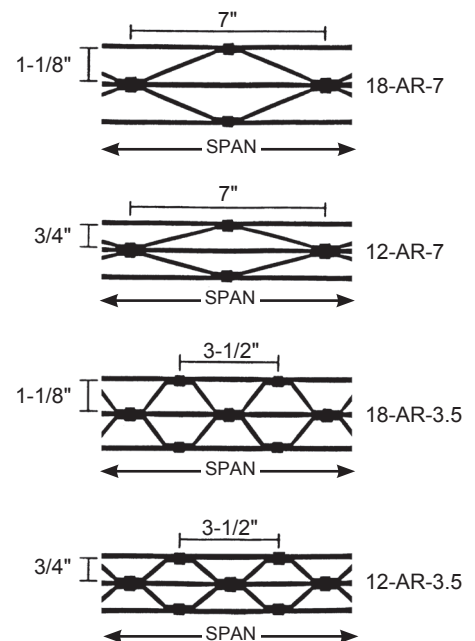

18-AR-7 & 18-AR-3-1/2

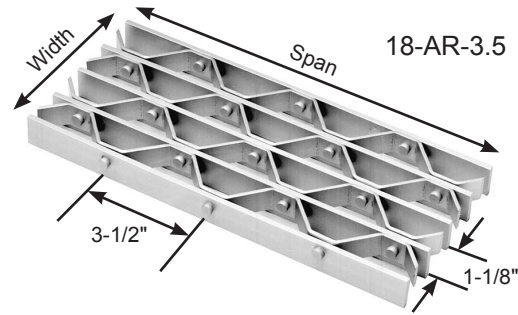
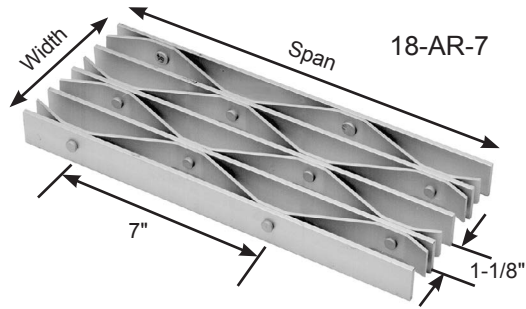

Bar Size, Inches	Ped Span, Inches	Wt.* Lbs. Sq. Ft.	Sec. Prop Sx*, in ³ Ix*, in ⁴	ClearSpan												
				2'- 0"	2'- 6"	3'- 0"	3'- 6"	4'- 0"	4'- 6"	5'- 0"	5'- 6"	6'- 0"	6'- 6"	7'- 0"	8'- 0"	
1 x 1/8	41	2.70	0.242	U	484	310	215	158								
				D	0.144	0.225	0.324	0.441								
				C	484	387	323	277								
1 x 3/16	45	3.30	0.363	U	726	465	323	237	182							
				D	0.144	0.225	0.324	0.441	0.577							
				C	726	581	484	415	363							
1-1/4 x 1/8	48	3.10	0.378	U	757	484	336	247	189	149						
				D	0.115	0.180	0.259	0.353	0.460	0.581						
				C	757	605	504	432	378	336						
1-1/4 x 3/16	53	3.80	0.567	U	1135	726	504	371	284	224						
				D	0.115	0.180	0.259	0.353	0.461	0.583						
				C	1135	908	757	648	567	504						
1-1/2 x 1/8	55	3.40	0.545	U	1089	697	484	356	272	215	174					
				D	0.096	0.150	0.216	0.294	0.383	0.486	0.599					
				C	1089	872	726	623	545	484	436					
1-1/2 x 3/16	61	4.40	0.817	U	1634	1046	726	534	409	323	261	216				
				D	0.096	0.150	0.216	0.294	0.384	0.486	0.599	0.726				
				C	1634	1307	1089	934	817	726	654	594				
1-3/4 x 3/16	69	4.90	1.112	U	2224	1424	989	726	556	439	356	294	247			
				D	0.082	0.129	0.185	0.252	0.329	0.416	0.514	0.622	0.740			
				C	2224	1779	1483	1271	1112	989	890	809	741			
2 x 3/16	76	5.80	1.453	U	2905	1859	1291	949	726	574	465	384	323	275		
				D	0.072	0.112	0.162	0.221	0.288	0.365	0.450	0.544	0.648	0.760		
				C	2905	2324	1937	1660	1453	1291	1162	1056	968	894		
2-1/4 x 3/16	83	6.40	1.838	U	3677	2353	1634	1201	919	726	588	486	409	348	300	
				D	0.064	0.100	0.144	0.196	0.256	0.324	0.400	0.484	0.577	0.676	0.784	
				C	3677	2942	2451	2101	1838	1634	1471	1337	1226	1131	1051	
2-1/2 x 3/16	90	6.90	2.270	U	4539	2905	2018	1482	1135	897	726	600	504	430	371	284
				D	0.058	0.090	0.130	0.176	0.230	0.292	0.360	0.435	0.518	0.609	0.706	0.823
				C	4539	3632	3026	2594	2270	2018	1816	1651	1513	1397	1297	1135
2-1/2 x 3/16	90	6.90	2.837	U	4539	2905	2018	1482	1135	897	726	600	504	430	371	284
				D	0.046	0.072	0.104	0.141	0.184	0.233	0.288	0.349	0.415	0.487	0.564	0.654
				C	4539	3632	3026	2594	2270	2018	1816	1651	1513	1397	1297	1135

U - Safe uniform load in pounds/sq. ft.
 C - Safe concentrated load in pounds/ft. grating width
 D - Deflection in inches

Loads and deflections given in this table are theoretical, and are based on a unit stress of 12,000 psi.

% Open Area*		
Bars	1/8"	3/16"
7" cc	78%	74%
3-1/2" cc	77%	73%

BB Size, Inches	CB Size, in. All Spacings
Thru 1-3/4	3/4 x 1/8
2 - 2-1/2	1 x 1/8

* Based on 11.621 bars/ft. of grating width. Bearing bars 1-1/8" face-to-face, connecting bars riveted 7" c.c. Add .2 lbs./sq. ft. for 18-AR-3-1/2. Note: Grating for spans to the left of the heavy line have a deflection less than 1/4" for uniform loads of 100 lbs./sq. ft. This is the maximum deflection to afford pedestrian comfort and can be exceeded for other types of load at the discretion of the engineer. The actual Ped (pedestrian) Span under this condition is shown above for each size of grating.

Panel Width Chart (in.) - 18-AR-7 & 18-AR-3-1/2 Dimensions Are Out-to-Out of Bearing Bars**

No. of Bars	2	3	4	5	6	7	8	9	10	11	12	13	14	15	16
3/16" Bars	1-1/2	2-13/16	4-1/8	5-7/16	6-3/4	8-1/16	9-3/8	10-11/16	12	13-5/16	14-5/8	15-15/16	17-1/4	18-9/16	19-7/8
No. of Bars	17	18	19	20	21	22	23	24	25	26	27	28			
3/16" Bars	21-3/16	22-1/2	23-13/16	25-1/8	26-7/16	27-3/4	29-1/16	30-3/8	31-11/16	33	34-5/16	35-5/8			

**Add 1/4" for rivet heads. Deduct 1/16" for each 1/8" bearing bar. Standard panel widths indicated in teal.

12-AR-7 & 12-AR-3-1/2

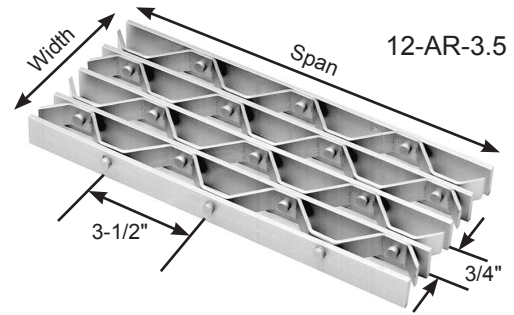
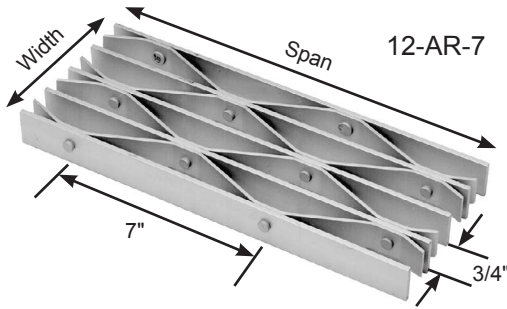

Bar Size, Inches	Ped Span, Inches	Wt.* Lbs. Sq. Ft.	Sec. Prop Sx*, in ³ Ix*, in ⁴	ClearSpan													
				2'- 0"	2'- 6"	3'- 0"	3'- 6"	4'- 0"	4'- 6"	5'- 0"	5'- 6"	6'- 0"	6'- 6"	7'- 0"	8'- 0"		
1 x 3/16	49	4.50	0.508	U	1017	651	452	332	254	201	U - Safe uniform load in pounds/sq. ft. C - Safe concentrated load in pounds/ft. grating width D - Deflection in inches Loads and deflections given in this table are theoretical and are based on a unit stress of 12,000 psi.						
				D	0.144	0.225	0.324	0.441	0.576	0.730							
			0.254	C	1017	813	678	581	508	452							
				D	0.115	0.180	0.259	0.353	0.460	0.583							
1-1/4 x 3/16	58	5.30	0.794	U	1589	1017	706	519	397	314	254	U - Safe uniform load in pounds/sq. ft. C - Safe concentrated load in pounds/ft. grating width D - Deflection in inches Loads and deflections given in this table are theoretical and are based on a unit stress of 12,000 psi.					
				D	0.115	0.180	0.259	0.353	0.461	0.584	0.719						
			0.496	C	1589	1271	1059	908	794	706	636						
				D	0.092	0.144	0.207	0.282	0.368	0.466	0.576						
1-1/2 x 3/16	67	6.10	1.144	U	2288	1464	1017	747	572	452	366	303	254	% Open Area* 7" cc 65% 3-1/2" cc 64%			
				D	0.096	0.150	0.216	0.294	0.384	0.486	0.600	0.727	0.863				
			0.858	C	2288	1830	1525	1307	1144	1017	915	832	763				
				D	0.077	0.120	0.173	0.235	0.307	0.389	0.480	0.581	0.692				
1-3/4 x 3/16	75	6.80	1.557	U	3114	1993	1384	1017	778	615	498	412	346	295			
				D	0.082	0.129	0.185	0.252	0.329	0.416	0.514	0.623	0.741	0.870			
			1.362	C	3114	2491	2076	1779	1557	1384	1246	1132	1038	958			
				D	0.066	0.103	0.148	0.202	0.263	0.333	0.412	0.498	0.592	0.695			
2 x 3/16	83	8.10	2.034	U	4067	2603	1808	1328	1017	803	651	538	452	385	332		
				D	0.072	0.112	0.162	0.220	0.288	0.364	0.450	0.545	0.648	0.760	0.882		
			2.034	C	4067	3254	2712	2324	2034	1808	1627	1479	1356	1251	1162		
				D	0.058	0.090	0.130	0.176	0.230	0.292	0.360	0.436	0.518	0.608	0.706		
2-1/4 x 3/16	90	8.90	2.574	U	5148	3294	2288	1681	1287	1017	824	681	572	487	420	322	
				D	0.064	0.100	0.144	0.196	0.256	0.324	0.400	0.484	0.576	0.676	0.784	1.025	
			2.896	C	5148	4118	3432	2941	2574	2288	2059	1872	1716	1584	1471	1287	
				D	0.051	0.080	0.115	0.157	0.205	0.259	0.320	0.387	0.461	0.541	0.627	0.819	
2-1/2 x 3/16	98	9.60	3.178	U	6355	4067	2824	2075	1589	1255	1017	840	706	602	519	397	
				D	0.058	0.090	0.130	0.176	0.230	0.292	0.360	0.435	0.518	0.609	0.706	0.921	
			3.972	C	6355	5084	4237	3631	3178	2824	2542	2311	2118	1955	1816	1589	
				D	0.046	0.072	0.104	0.141	0.184	0.233	0.288	0.348	0.415	0.487	0.565	0.737	

*Based on 16.269 bars/ft. of grating width. Bearing bars 3/4" face-to-face, connecting bars riveted 7" c.c. Add .2 lbs./sq. ft. for 12-AR-3-1/2. 1/8" by inquiry. Note: Grating for spans to the left of the heavy line have a deflection less than 1/4" for uniform loads of 100 lbs./sq. ft. This is the maximum deflection to afford pedestrian comfort and can be exceeded for other types of load at the discretion of the engineer. The actual Ped (pedestrian) Span under this condition is shown above for each size of grating.

Panel Width Chart (in.) - 12-AR-7 & 12-AR-3-1/2 Dimensions Are Out-to-Out of Bearing Bars**

No. of Bars	2	3	4	5	6	7	8	9	10	11	12	13	14	15	16
3/16" Bars	1-1/8	2-1/16	3	3-15/16	4-7/8	5-13/16	6-3/4	7-11/16	8-5/8	9-9/16	10-1/2	11-7/16	12-3/8	13-5/16	14-1/4
No. of Bars	17	18	19	20	21	22	23	24	25	26	27	28	29	30	31
3/16" Bars	15-3/16	16-1/8	17-1/16	18	18-15/16	19-7/8	20-13/16	21-3/4	22-11/16	23-5/8	24-9/16	25-1/2	26-7/16	27-3/8	28-5/16
No. of Bars	32	33	34	35	36	37	38	39							
3/16" Bars	29-1/4	30-3/16	31-1/8	32-1/16	33	33-15/16	34-7/8	35-13/16							

**Add 1/4" for rivet heads. Deduct 1/16" for each 1/8" bearing bar. Standard panel widths indicated in teal.

ALUMINUM PLANK



PLANK

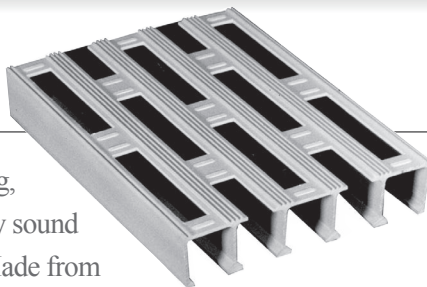

As an alternative to bar grating, aluminum plank is structurally sound and cosmetically attractive. Made from extruded aluminum, plank grating is relatively maintenance free and has no parts to work loose or splinter. The surface can be provided unpunched or with a variety of punch patterns for the passage of air, light, heat or moisture. A diagonal pattern is also available which meets the ADA requirements for wheelchair accessibility and high heel foot traffic.

The interconnecting webs offer a flush top walking surface for maximum foot contact and comfort. Plank can be used as an alternative to applications requiring open grating with plate attached to the top surface. OnGrip® Spray Traction Surface is also available. Aluminum Plank is used at waste water treatment plants, for entranceways, walkways, bridges, trails, marine refrigeration, stadiums and more.

PLANK SECTION AVAILABILITY...

Heavy Duty (Plain Sides)

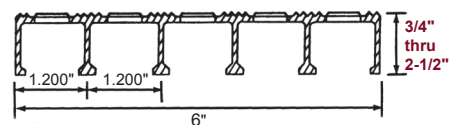

Heavy Duty (Interlocking Sides)

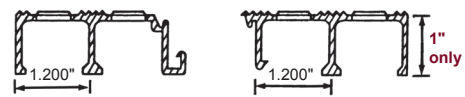
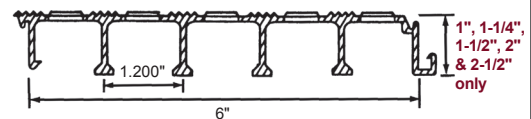

2-1/2" Female Edge

2-1/2" Male Edge

Light Series (Plain Sides)

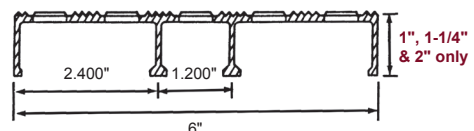

ALUMINUM PLANK

PLANK SECTION AVAILABILITY (continued)...

Aluminum plank grating is available in five cross-sectional designs: Heavy Duty (plain sides/interlocking sides), Light Series (plain sides) and Reefer (interlocking sides). The Heavy Duty sections are used primarily in the water and waste treatment markets and the marine market, while the Light Series and Reefer sections are used exclusively in the marine refrigerated stores application. Interlocking Heavy Duty and Reefer sections and edge sections are available in 1" deep grating only.

NOTE: Plank is also available in a Pivot-Lock interlocking design by special request.

Reefer (Interlocking Sides)

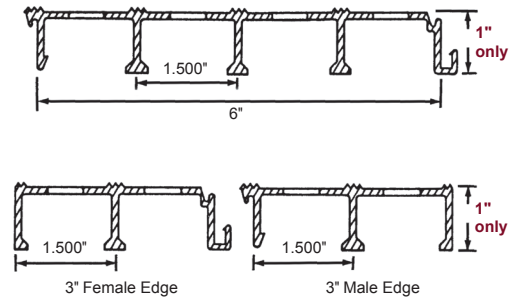

PUNCH PATTERN GUIDE

Aluminum plank grating is available unpunched or with a variety of punch patterns as shown. Rectangular or square punched holes are most commonly used for water and waste treatment plants and in marine applications.

The surface of plank grating can be specified as plain or with one of two styles of upsets (OGI or WACO) designed to promote a slip resistant walkway, especially in the presence of moisture, oil or other spilled substances.

All of our Diagonal Punched Patterns meet ADA specifications for high heel and wheelchair traffic.

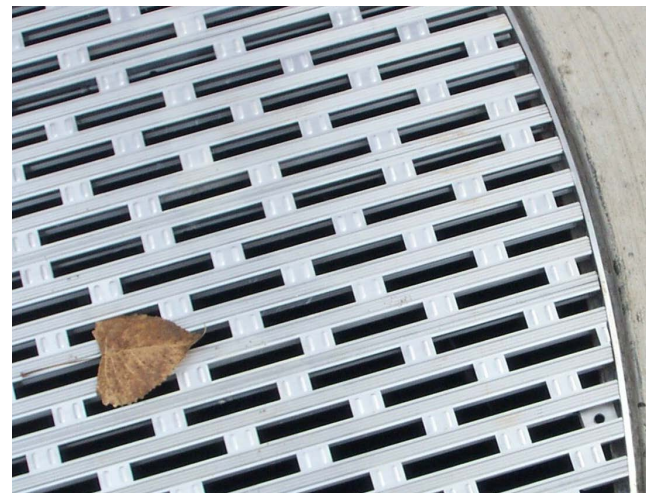

Upset Pattern (OGI)

*Alternate for plate covered aluminum grating

UNPUNCHED	SQUARE PUNCHED		RECTANGULAR PUNCHED		
<p>6" Typ</p> <p>HEAVY DUTY, LIGHT SERIES</p>	<p>Upset Pattern 6" Typ</p> <p>HEAVY DUTY, LIGHT SERIES</p>	<p>Plain Pattern</p> <p>HEAVY DUTY, LIGHT SERIES</p>	<p>Upset Pattern (OGI) 6" Typ</p> <p>3" Typ 1" Typ 19/32" Typ</p> <p>HEAVY DUTY, LIGHT SERIES</p>	<p>Upset Pattern (WACO)</p> <p>HEAVY DUTY, LIGHT SERIES</p>	<p>Plain Pattern</p> <p>HEAVY DUTY, LIGHT SERIES</p>

ALUMINUM PLANK

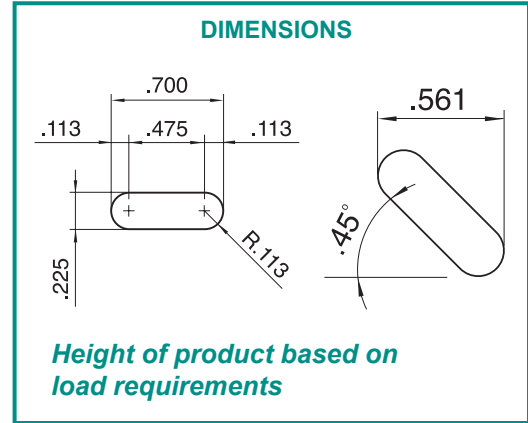
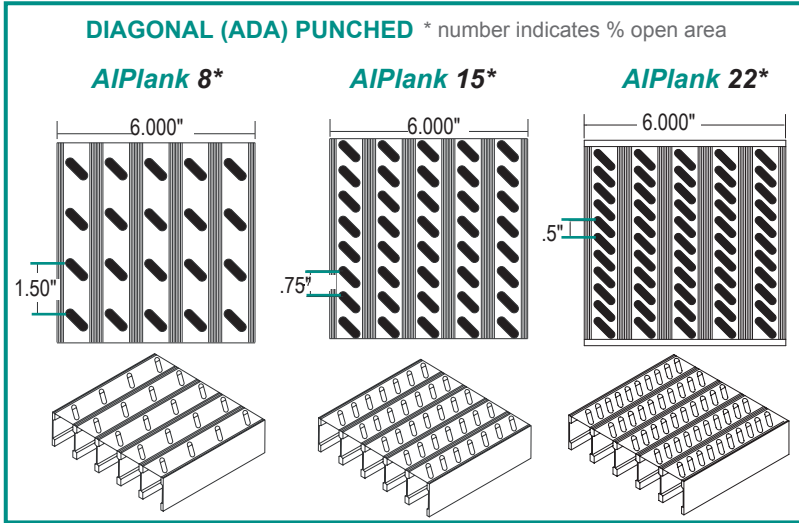

NOTE: Other non-ADA punch styles (round, oval slot and dog bone) are available by special request.

PLANK FABRICATION

Aluminum plank grating is available in 20' or 26' lengths for customer fabrication, or as fabricated by Ohio Gratings according to customer plans and specifications.

Individual 6" plank sections can be banded together to form standard panel widths for ease of handling and installation. When the width of the total grating "run" (number of continuous series of panels) does not result in a total measurement evenly divisible by the 6" sections, the last

panel can be fabricated from several whole sections and a partial section according to the panel width chart shown. In order to meet flatness tolerances, fabricated panels must always be end banded, and should not exceed 36" in width.

The two arrows on the typical panel layout show the span direction which runs at right angles to the supporting members. Identical panels have the same mark numbers. Cutouts and banding are charged as extras according to quantity and size.

Typical Panel Layout

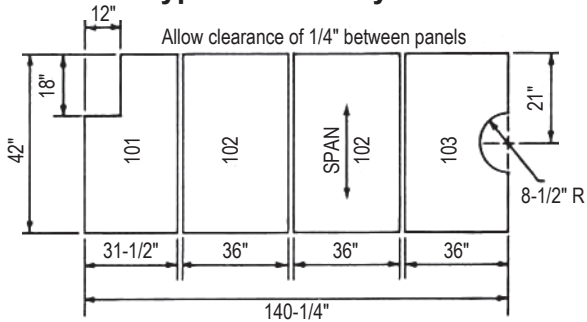

NOTE: Panels made from 6" sections and partial sections are banded on the ends only. Side bands typically are not furnished, unless specified by the customer.

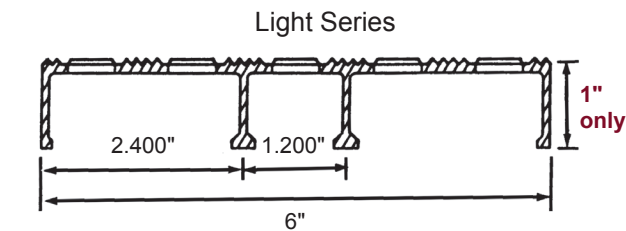

Note: Grating for spans to the left of the heavy line have a deflection less than 1/4" for uniform loads of 100 lbs./sq. ft. This is the maximum deflection to afford pedestrian comfort and can be exceeded for other types of load at the discretion of the engineer. The actual Ped (pedestrian) Span under this condition is shown above for each size of grating. This grating conforms to MIL-G-18015 (SHIPS).

Panel Width Chart (in.)

	1-1/2	2-11/16	3-7/8	5-1/8
6	7-1/2	8-11/16	9-7/8	11-1/8
12	13-1/2	14-11/16	15-7/8	17-1/8
18	19-1/2	20-11/16	21-7/8	23-1/8
24	25-1/2	26-11/16	27-7/8	29-1/8
30	31-1/2	32-11/16	33-7/8	35-1/8
36				

LIGHT SERIES LOAD TABLE

Plank Size, Inches	Sec. Prop Sx*, in ³ Ix*, in ⁴	Weight Per Sq. Ft.			ClearSpan						
		Non Punched	Rect. Punched	Square Punched	2'- 0"	2'- 6"	3'- 0"	3'- 6"	4'- 0"	4'- 6"	
1	0.273	2.1	1.7	1.9	U	546	349	242	178	136	107
					D	0.113	0.177	0.254	0.347	0.452	0.570
	0.173				C	546	436	364	312	273	242
					D	0.090	0.141	0.204	0.278	0.363	0.458

NOTE: Contact OGI for load ratings on the 2" size.

ALUMINUM PLANK

% Open Area*	
Rect.	37%
Square	23%

% Open Area*	
Round 13/16" Dia.	23%
Round 1" Dia.	26%

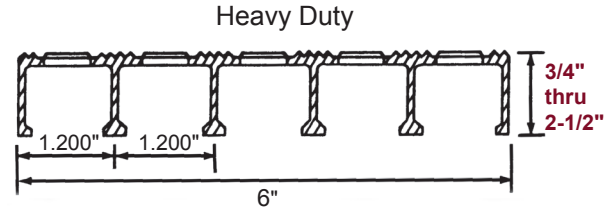

HEAVY DUTY LOAD TABLE *Based on punched plank.

Plank Size, Inches	Ped Span, Inches	Sec. Prop Sx ² , in ³ lx ² , in ⁴	Weight Per Sq. Ft.			ClearSpan																	
			Non Punched	Rect. Punched	Square Punched	2'- 0"	2'- 6"	3'- 0"	3'- 6"	4'- 0"	4'- 6"	5'- 0"	5'- 6"	6'- 0"	6'- 6"	7'- 0"	8'- 0"						
3/4	39	0.217	2.2	1.8	2.0	U	435	278	193	142	108	85	69	U - Safe uniform load in pounds/sq. ft. C - Safe concentrated load in pounds/ft. grating width D - Deflection in inches Loads and deflections given in this table are theoretical, and are based on a unit stress of 12,000 psi.									
						D	0.121	0.237	0.342	0.465	0.608	0.770	0.950										
		C	435	348	290	248	217	193	174														
		D	0.121	0.190	0.273	0.371	0.485	0.614	0.760														
1	49	0.416	2.6	2.2	2.4	U	833	533	370	272	208	164	133						110	92			
						D	0.124	0.193	0.279	0.380	0.496	0.628	0.775						0.938	1.117			
		C	833	666	555	476	416	370	333	302	277												
		D	0.099	0.155	0.223	0.304	0.396	0.502	0.620	0.748	0.891												
1-1/4	58	0.732	3.2	2.8	3.0	U	1464	936	650	478	366	289	234						193	162	138	119	91
						D	0.107	0.167	0.241	0.328	0.428	0.542	0.669						0.810	0.964	1.131	1.312	1.714
		C	1464	1171	976	836	732	650	585	532	488	450	418						366				
		D	0.085	0.133	0.192	0.262	0.342	0.433	0.535	0.647	0.771	0.904	1.049						1.371				
1-1/2	67	1.083	3.8	3.4	3.6	U	2167	1387	963	707	541	428	346	286	240	205	176	135					
						D	0.090	0.141	0.203	0.277	0.362	0.458	0.566	0.684	0.815	0.956	1.109	1.449					
		C	2167	1734	1445	1238	1083	963	867	788	722	666	619	541									
		D	0.072	0.113	0.163	0.221	0.289	0.366	0.452	0.547	0.651	0.764	0.887	1.157									
1-3/4	75	1.496	4.4	4.0	4.2	U	2992	1915	1330	977	748	591	478	395	332	283	244	187					
						D	0.078	0.123	0.177	0.241	0.315	0.398	0.492	0.595	0.708	0.832	0.964	1.260					
		C	2992	2394	1995	1710	1496	1330	1197	1088	997	920	855	748									
		D	0.062	0.098	0.141	0.192	0.251	0.318	0.393	0.476	0.566	0.664	0.771	1.007									
2	83	1.987	4.9	4.5	4.7	U	3975	2544	1766	1298	993	785	636	525	441	376	324	248					
						D	0.069	0.108	0.156	0.212	0.277	0.351	0.433	0.524	0.624	0.732	0.849	1.109					
		C	3975	3180	2650	2271	1987	1766	1590	1445	1325	1223	1135	993									
		D	0.055	0.086	0.124	0.169	0.221	0.280	0.346	0.419	0.499	0.586	0.679	0.887									
2-1/4	91	2.554	5.5	5.0	5.3	U	5109	3270	2270	1668	1277	1009	817	675	567	483	417	319					
						D	0.061	0.095	0.137	0.187	0.244	0.309	0.382	0.462	0.550	0.646	0.749	0.979					
		C	5109	4087	3406	2919	2554	2270	2043	1858	1703	1572	1459	1277									
		D	0.048	0.076	0.110	0.149	0.195	0.247	0.305	0.370	0.440	0.517	0.599	0.783									
2-1/2	97	2.985	5.9	5.5	5.7	U	5971	3821	2654	1949	1492	1179	955	789	663	565	487	373					
						D	0.055	0.086	0.124	0.169	0.221	0.279	0.345	0.418	0.497	0.584	0.677	0.884					
		C	5971	4777	3981	3412	2985	2654	2388	2171	1990	1837	1706	1492									
		D	0.044	0.069	0.099	0.135	0.176	0.223	0.276	0.334	0.398	0.467	0.541	0.707									

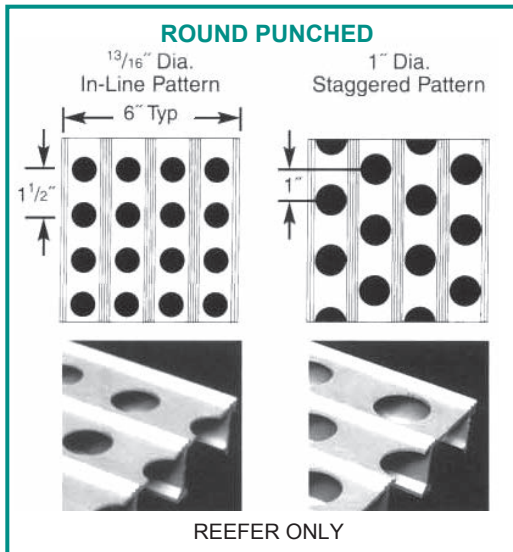

Reffer (Interlocking Sides)

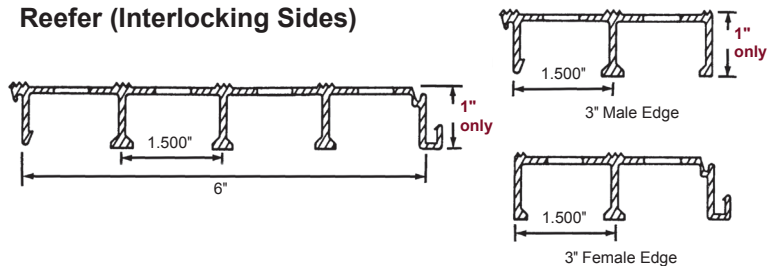

REEFER LOAD TABLE

Plank Size, Inches	Sec. Prop Sx ² , in ³ lx ² , in ⁴	Weight Per Sq. Ft.			ClearSpan						
		Non Punched	13/16" Dia. In-line	1" Dia. Staggered	2'- 0"	2'- 6"	3'- 0"	3'- 6"	4'- 0"	4'- 6"	
1	0.384	2.8	2.5	2.5	U	768	491	341	250	192	151
					D	0.130	0.203	0.292	0.397	0.521	0.656
	0.211				C	768	614	512	438	304	341
					D	0.104	0.163	0.235	0.319	0.417	0.528

ALUMINUM PLANK

PLANK TYPE "F" TREADS

Aluminum plank stair treads can be furnished as fabricated from full and partial plank sections with end plates and nosings or as individual extrusions with welded end plates, referred to as Type "F" treads. Type "F" treads are produced from a high-strength aluminum alloy, and meet requirements as specified by BuShips Hull Type plan BU-No. 1604-860041. Type "F" treads are 1-3/4" deep and are available in widths of 4", 6" or 9". The top surface can be supplied unpunched, or with a rectangular punched upset pattern. Type "F" treads are generally used for shipboard application, however, they can also provide safe, serviceable steps for ladder in sewage disposal, chemical and power plants, and refineries.

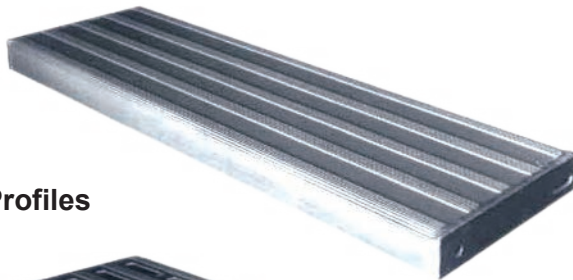

Panel Profiles



Typical Panel Layout

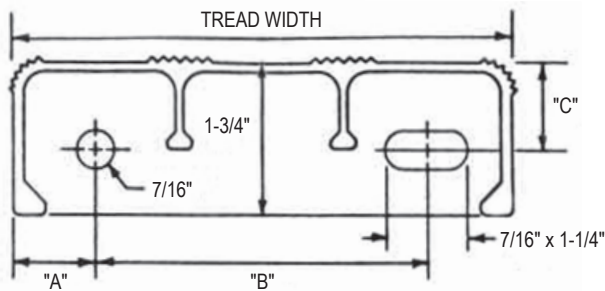

Tread Width	Lbs. Per Lin. Ft.		Dimensions			Suggested Max. Tread Length
	Unpunched	Punched	"A"	"B"	"C"	
4"	1.48	1.38	1"	2"	1"	3' - 8"
6"	1.90	1.75	1"	4"	1"	4' - 0"
9"	2.72	2.52	1-1/4"	6-1/2"	1"	5' - 1"

Punch Pattern Availability

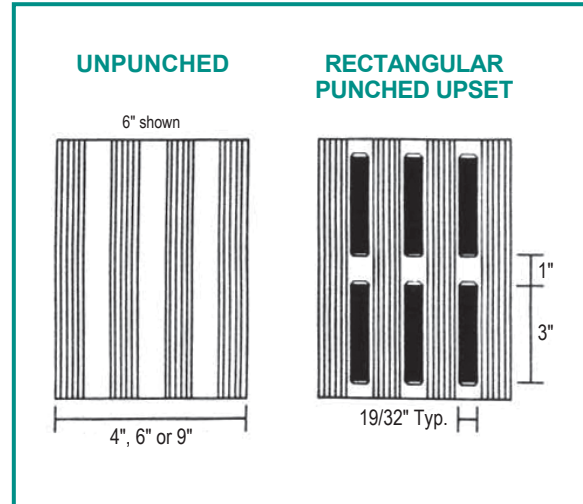

Section Availability

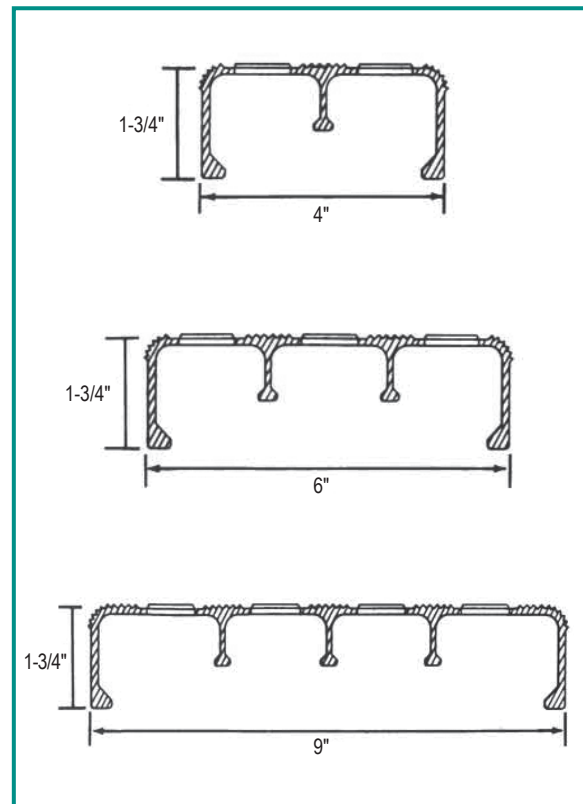

ALUMINUM PLANK APPLICATIONS

Plank Applications

PLANK LUG

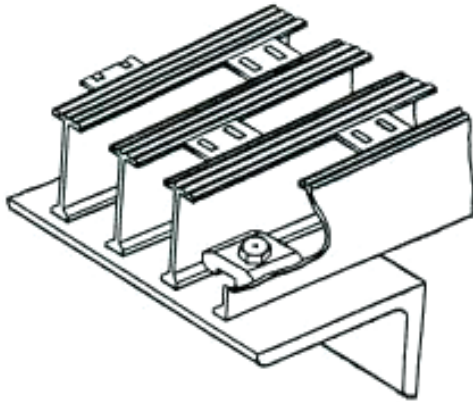

A plank lug inserted and tack welded between flanges, can serve as an anchor block for plank grating.

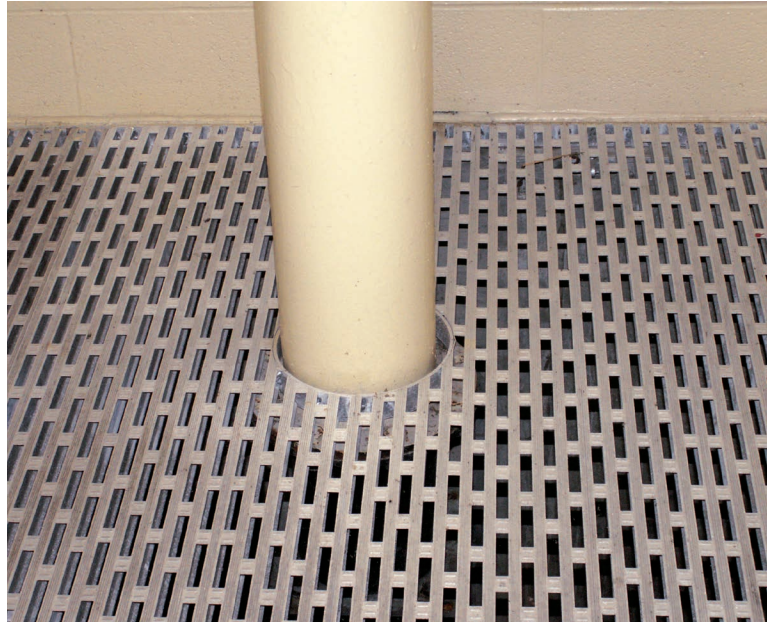

PLANK LUG DETAIL
(4 required per panel)

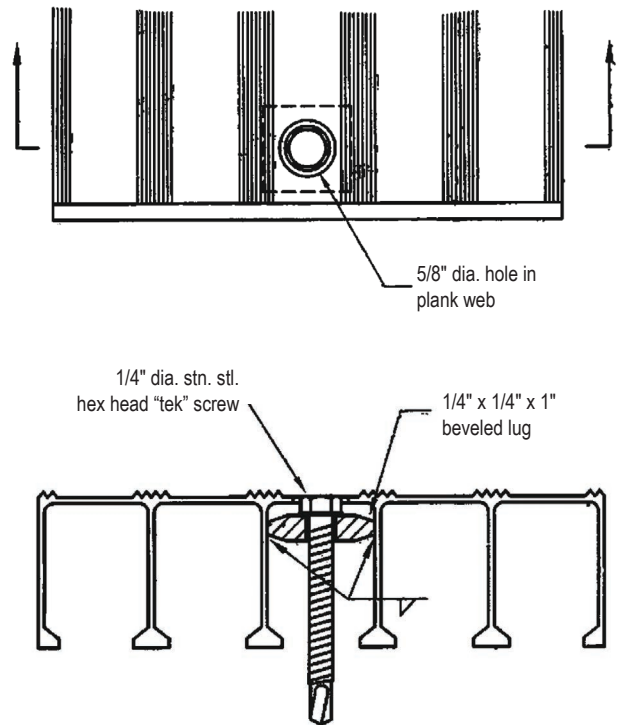

ALUMINUM GRATING FRAMES



GRATING FRAMES

In conjunction with aluminum grating, Ohio Gratings offers an extruded aluminum grating frame for embedded concrete applications. This frame features a continuous ledge to accommodate plank fasteners, grating clamps, or self-tapping screws for other types of fasteners. The continuous anchor can be used alone or with supplementary anchor straps. Angle frame is available fabricated per drawings with mitred and welded corners or in long lengths with prefabricated corners for installation in the field. Frames can be provided in the mill finish condition or powder coated to protect surfaces which will come into contact with concrete.

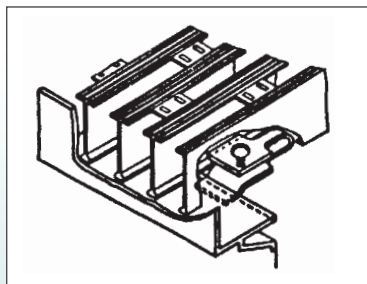
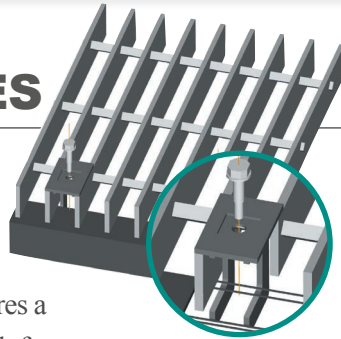

◀ **Plank Grating with E Clip.**
(Compatible with 1/4" flange thickness.
Anchor not shown.)

GRATING FRAME DIMENSIONS

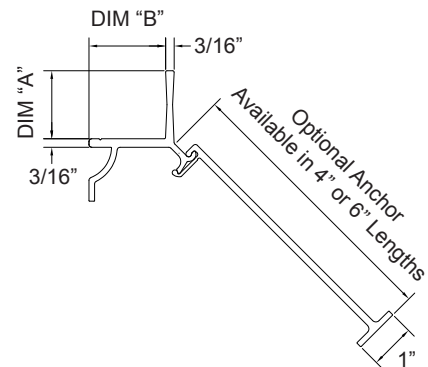

GR. SIZE	DIM "A"	DIM "B"
1"	1"	1-11/16"
1-1/4"	1-1/4"	1-11/16"
1-1/2"	1-1/2"	1-11/16"
1-3/4"	1-3/4"	1-11/16"
2"	2"	1-11/16"
2-1/4"	2-1/4"	2-11/16"
2-1/2"	2-1/2"	2-11/16"

ALUMINUM GRATING FRAMES

MINI CASE STUDY

Wastewater Treatment Plant Massillon, OH

The city began a major expansion project in 2002. Once again, aluminum was specified for the walkways in and around the plant. We provided our aluminum plank and “I-Bar” along with our aluminum angle frame.

Angle frame is available (see diagram) with mitred and welded corners. Long lengths are available with prefabricated corners for handy installations in the field (miscellaneous steel fabricators prefer aluminum for this reason in addition to the fact that it is lightweight, flexible and easily altered in the field).

Frames can be provided in mill finish or with a powder coat finish to protect surfaces that are in direct contact with concrete.

Optional Anchor

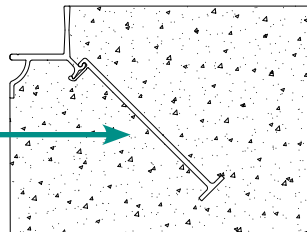

Fabrication Guidelines

Frame sections can be purchased in stock lengths for customer fabrication or can be fabricated by Ohio Gratings for immediate installation in the field.

The following Guidelines apply to Fabricated Frames

1. All corners are mitred at 45 degrees and welded on the back side. Welds are not ground.
2. Nominal small frames (i.e. 1'0" x 1'0" through 5 x 10'0") are made in one piece.
3. Extended trench frames are provided with prefabricated end sections and long lengths shipped loose for field butt joining.
4. Stock lengths are 20'0". Longer lengths are available by request.

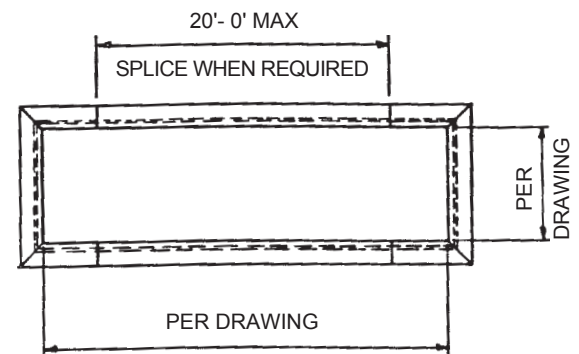

Plan View

STAIR TREADS



STAIR TREADS

Most grating platform and walkway applications require stair treads to access the various levels that are inherent in most project applications. We offer a full range of aluminum, carbon and stainless steel grating tread profiles to meet the various demands in the marketplace. Whether the project requires a standard maintenance access tread or a closer mesh and more pedestrian friendly (ADA) product, Ohio Gratings can offer a variety of competitive and cost effective products.

Our sales team and engineering support group can help with product specifications regarding OnGrip® Spray Traction Surface as well as selecting the appropriate nosing for the tread to meet the needs of the client. Nosing options are shown on pages 36 and 37 for both steel and aluminum products along with tread details of each of the material types including the slip resistant options. Stair treads are available with equal end dimensions for cross bar alignment.

STAIR TREAD TOLERANCES

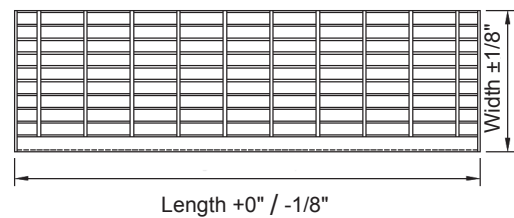

Overall Dimensional Tolerances

Note: Length of Tread is distance between outer faces of Carrier Plates.

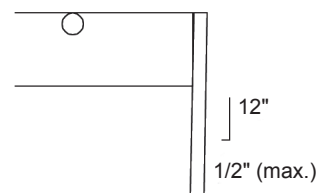

Carrier Plate Lean

STAIR TREADS

ALUMINUM STAIR TREAD DETAILS

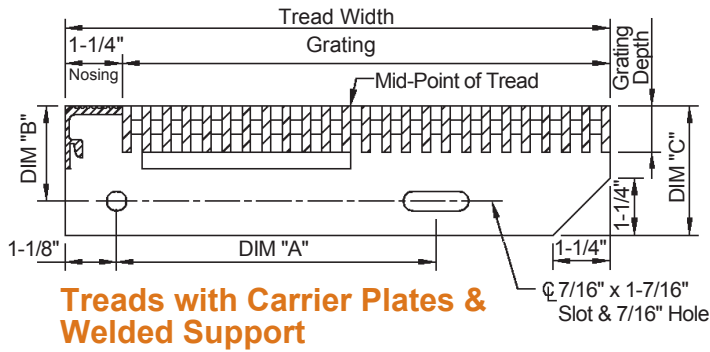
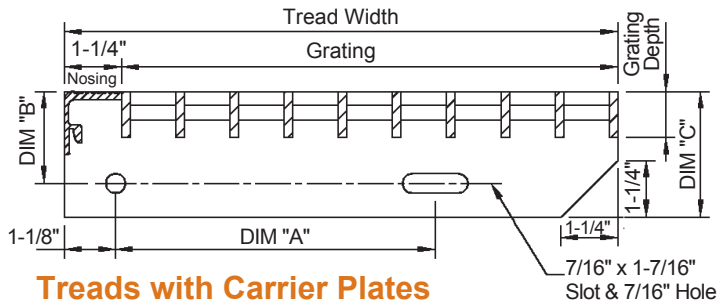

For Close Mesh Grating, 7 & 11 spaced grating. 8 Spacing (1/2" c.c.) available upon request. Please call for details.

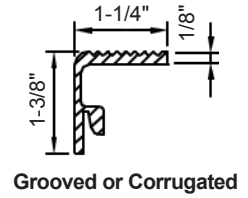
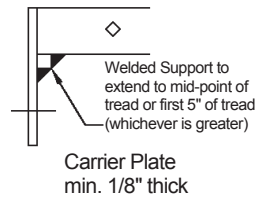
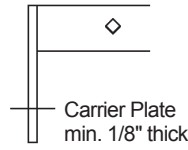

Nosing Details

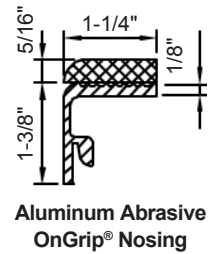
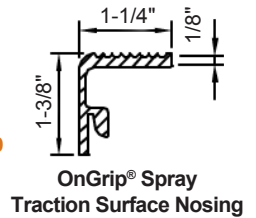

STEEL STAIR TREAD DETAILS

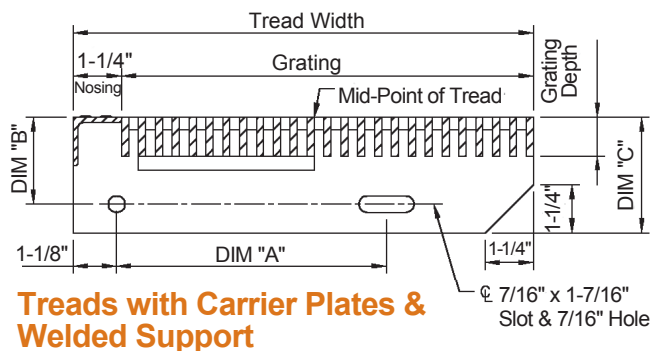
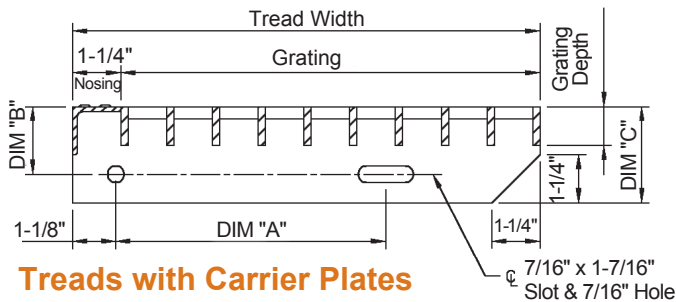

For Close Mesh Grating, 7 & 11 spaced grating. 8 Spacing (1/2" c.c.) available upon request. Please call for details.

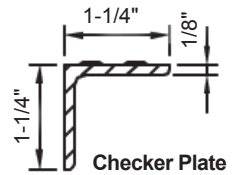
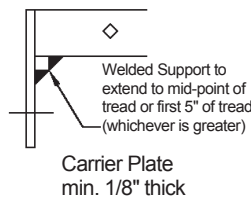
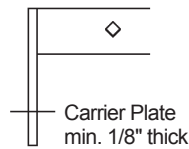

Nosing Details

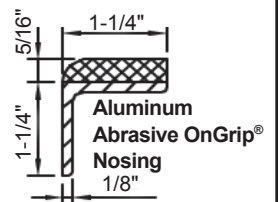
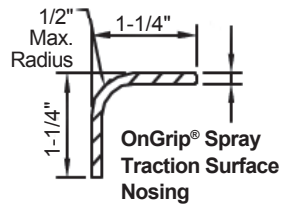

STAIR TREADS

ALUMINUM STAIR TREAD

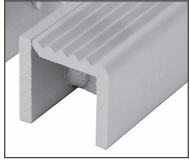

◀ **Grooved Nosing**
Standard on
Aluminum Treads

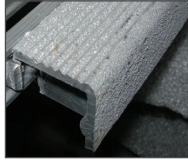

◀ **OnGrip® Spray**
Traction Surface
Nosing is also
available

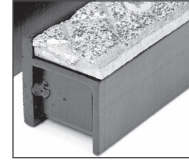

◀ **Aluminum Abrasive**
OnGrip® Nosing
also available on
aluminum treads

Standard Tread Widths¹

# of bearing bars	Width (includes nosing)					DIM "A"
	SG, SDF, ADT Series	SGI Series	SGLi Series	AR Series	Plank Series	
5	6-3/16"	6-1/4"	6-3/16"	6-11/16"	6-3/8"	2-1/2"
6	7-3/8"	7-7/16"	7-3/8"	8"	7-1/4"	4-1/2"
7	8-9/16"	8-5/8"	8-9/16"	9-5/16"	8-3/4"	4-1/2"
8	9-3/4"	9-13/16"	9-3/4"	10-5/8"	9-15/16"	7"
9	10-15/16"	11"	10-15/16"	11-15/16"	11-1/8"	7"
10	12-1/8"	12-3/16"	12-1/8"	13-1/4"	12-3/8"	7"

Carrier Plate Dimensions

Grating Depth	DIM "B"	DIM "C"
1"	2-1/4"	3"
1-1/4"	2-1/4"	3"
1-1/2"	2-1/4"	3"
1-3/4"	2-1/4"	3"
2"	3-1/4"	4"
2-1/4"	3-1/4"	4"
2-1/2"	3-1/4"	4"

Max Plank Tread Length²

Grating Depth	Plank ³ Grating
1"	30
1-1/4"	36
1-1/2"	44
1-3/4"	53
2"	63
2-1/4"	66
2-1/2"	70

Maximum Tread Length² (in.)

Bar Size, Inches	SG, SGF, ADT Series Plain Surface				SG, SGF, ADT Series Serrated Surface				SGI Series Striated Surface				SGLi Series Striated Surface			
	19 1-3/16" c.c.	15 15/16" c.c.	11 11/16" c.c.	7 7/16" c.c.	19 1-3/16" c.c.	15 15/16" c.c.	11 11/16" c.c.	7 7/16" c.c.	19 1-3/16" c.c.	15 15/16" c.c.	11 11/16" c.c.	7 7/16" c.c.	19 1-3/16" c.c.	15 15/16" c.c.	11 11/16" c.c.	7 7/16" c.c.
1 x 1/8	24	27	28	32	21	24	26	28								
1 x 3/16	28	30	32	36	26	27	28	32					24	28	29	34
1 x 1/4	31	33			27	29			28	30	32	36				
1-1/4 x 1/8	30	32	34	40	28	30	31	36								
1-1/4 x 3/16	34	37	40	47	31	33	36	41					31	34	36	43
1-1/4 x 1/4	38	41			34	37			34	37	40	47				
1-1/2 x 1/8	36	39	42	50	33	36	38	45								
1-1/2 x 3/16	42	46	50	59	38	42	45	53					37	40	43	53
1-1/2 x 1/4	47	52			43	47			42	46	50	59				
1-3/4 x 3/16	51	56	61	66	46	51	55	66								
1-3/4 x 1/4	58	64			52	58			51	56	61	66				
2 x 3/16	61	66	66	68	56	61	66	66					52	57	62	66
2 x 1/4	66	66			63	66			61	66	66	68				
2-1/4 x 3/16	66	66	66	80	66	66	66	74								
2-1/4 x 1/4	66	69			66	66			66	66	66	80				
2-1/2 x 3/16	66	70	77	94	66	66	71	87					66	66	66	82
2-1/2 x 1/4	73	81			67	75			66	70	77	94				

Additional configurations available upon inquiry. 1. Table of widths based on 3/16" thick bearing bars (1/4" I-Bar) and standard 1-3/16" c.c. bar spacing (1-1/8" face-to-face for riveted grating. 2. Maximum tread length based on 300# concentrated load on front 5" of tread at center of tread length and max. D=1/240 of length. Design treads exceeding 66" length for 300# concentrated loads at 1/3 points. Note: Riveted grating treads available upon inquiry. See page 23 for description of Grating Series. 3. Plank Grating is standard Heavy Duty.

STAIR TREADS

STEEL STAIR TREAD

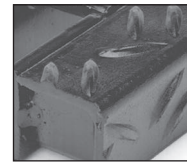

◀ **Checkerplate Nosing is Standard on Steel treads**

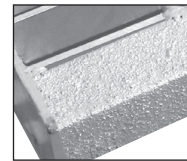

◀ **OnGrip® Spray Traction Surface Nosing is available**



◀ **Aluminum Abrasive OnGrip® Nosing is Available on Steel Treads**

Maximum Tread Length² (in.)

Bar Size, Inches	W, SGCS, SGSS, DT Series Plain Surface				W, SGCS, SGSS, DT Series Serrated Surface			
	19 1-3/16" c.c.	15 15/16" c.c.	11 11/16" c.c.	7 7/16" c.c.	19 1-3/16" c.c.	15 15/16" c.c.	11 11/16" c.c.	7 7/16" c.c.
1 x 1/8	31	36	41	51	27	30	34	45
1 x 3/16	41	48	51	59	34	40	45	51
1 x 1/4	49	53			42	46		
1-1/4 x 1/8	43	50	56	66	37	43	49	58
1-1/4 x 3/16	56	61	66	66	50	54	58	66
1-1/4 x 1/4	63	66			56	60		
1-1/2 x 1/8	56	65	66	66	49	58	63	66
1-1/2 x 3/16	66	66	66	76	63	66	66	68
1-1/2 x 1/4	66	67			66	66		
1-3/4 x 3/16	66	72	78	95	66	66	71	85
1-3/4 x 1/4	74	82			67	74		
2 x 3/16	78	87	95	115	72	79	86	105
2 x 1/4	89	99			82	91		
2-1/4 x 3/16	92	103	112	136	85	95	103	125
2-1/4 x 1/4	106	118			97	108		
2-1/2 x 3/16	107	119	130	159	100	111	121	148
2-1/2 x 1/4	123	137			114	127		

Carrier Plate Dimensions

Grating Depth	DIM "B"	DIM "C"
1"	1-3/4"	2-1/2"
1-1/4"	1-3/4"	2-1/2"
1-1/2"	2-1/4"	3"
1-3/4"	2-1/4"	3"
2"	3-1/4"	4"
2-1/4"	3-1/4"	4"
2-1/2"	3-1/4"	4"

Standard Tread Widths¹

# of bearing bars	Width (includes nosing)		DIM "A"
	W, SGCS, SGSS, DT Series	R Series	
5	6-3/16"	6-11/16"	2-1/2"
6	7-3/8"	8"	4-1/2"
7	8-9/16"	9-5/16"	4-1/2"
8	9-3/4"	10-5/8"	7"
9	10-15/16"	11-15/16"	7"
10	12-1/8"	13-1/4"	7"

Additional configurations available upon inquiry. 1. Table of widths based on 3/16" thick bearing bars (1/4" I-Bar) and standard 1-3/16" c.c. bar spacing (1-1/8" face-to-face for riveted grating. 2. Maximum tread length based on 300# concentrated load on front 5" of tread at center of tread length and max. D=1/240 of length. Design treads exceeding 66" length for 300# concentrated loads at 1/3 points. Note: Riveted grating treads available upon inquiry. See page 52 for description of Grating Series.

LIGHT DUTY STEEL FEATURES & BENEFITS

Features & Benefits

Light Duty Steel grating is the workhorse of the industrial flooring market, finding applications in conveyor systems, operating plants, highways and bridge platforms and walkways, machinery floors, refineries, tank stairways and walkways, and power plants. The open grid construction of steel grating provides maximum passage for light, air circulation and drainage, while offering low installation and maintenance costs.

Ohio Gratings prides itself on offering the widest selection of Light Duty Steel grating available in the industry. As a stocking, manufacturer and fabricator of electro forge welded steel grating, we inventory a variety of sizes and spacings for shipment in panel form, or for fabrication per plans and specs. OGI specializes in engineering those tough jobs requiring intricate layout and fabrication.

In addition to fabricating standard electro-forged welded steel grating, OGI manufactures and fabricates Dove Tail pressure locked grating, Riveted Steel grating, and Swaged Carbon and Stainless Steel grating. Dove Tail pressure locked, Riveted and Swaged grating offer smoother lines and a more pleasing appearance than the typical welded grating. While still industrial in nature, these grating types may be more appropriate than welded grating for some applications. Please contact the factory for assistance in choosing the right Light Duty Steel grating for your particular application.



“OGi specializes in complex projects requiring intricate layout and custom fabrication”

Whether the requirement is for stock panels or custom fabrication “Made Right and Shipped When Promised”, Ohio Gratings is the choice of a nationwide base of customers whose primary criteria are quality and service.



LIGHT DUTY STEEL PRODUCTS

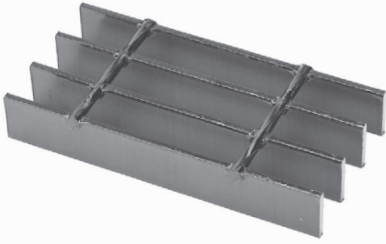

Light Duty Welded Steel

Electro-forging, a machine process combining hydraulic pressure and heat fusion, is the most popular and economical method for manufacturing steel grating panels. OGI offers stock panels for immediate shipment, or custom fabricated sizes. Various spacings, bar depths, finishes, and OnGrip® Spray Traction Surface is also available.



Light Duty Steel Dove Tail

Dove tail pressure locked grating offers the high strength and stiffness of welded steel grating along with the smooth, clean lines of a flush top rectangular cross bar. A variety of bar depths, finishes and spacings are available including 1/4" and 1/2" which conform to ADA requirements. OnGrip® Spray Traction Surface is also available.



Light Duty Swaged Carbon Steel

Swaged Carbon Steel grating is similar in construction to our aluminum bar grating products. Rectangular bearing bars and tubular cross bars are joined together via the swaging process. This process keeps the material free from the warping and weld flash inherent in the electroforging process. This profile offers the same flexibility as our other mechanically locked grating products as to multiple spacings (including ADA requirements), bar depths and finishes. OnGrip® Spray Traction Surface is also available.

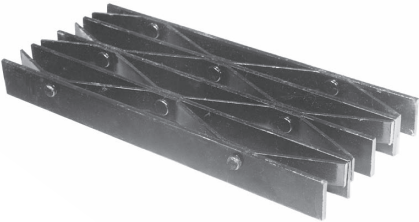

Light Duty Riveted Steel

Riveted grating is the oldest style of bar grating, but still the choice of many engineers due to its reliability and durability. OGI manufactures and fabricates multiple sizes and spacings. OnGrip® Spray Traction Surface is also available.



Light Duty PressLock

PressLock products are manufactured on our computer controlled production lines, where the bearing bars are notched and then "locked" with the cross bars at very high pressure. Available in increments of 7/16", PressLock offers a wide variety of mesh openings to match up to the appropriate loading requirements and project application. OnGrip® Spray Traction Surface is also available.



Light Duty Swaged Stainless Steel

Swaged Stainless Steel is offered in alloys of either Type 304 or 316. As with the swaged grating, this product is also manufactured free of the warping, twisting and burn marks which are characteristic of electroforged stainless grating. A variety of spacing options and bar depths are available, including those that meet ADA Requirements. OnGrip® Spray Traction Surface is also available.

LIGHT DUTY STEEL DESIGN CRITERIA

The tables of safe loads which follow have been computed using the following design parameters:

- U** = Uniform Load - lbs/ft²
- C** = Concentrated Load - lbs/ft of grating width
- S** = Section Modulus - in³/ft of grating width
- I** = Moment of Inertia - in⁴/ft of grating width
- L** = Simple Clear Span - feet
- D** = Deflection - inches
- E** = Modulus of Elasticity (Carbon Steel = 29,000,000 psi, T-304 and T-316 Stainless Steel = 28,000,000 psi)
- F** = Allowable Bending Stress (Carbon Steel = 18,000 psi, T-304 and T-316 Stainless Steel = 20,000 psi)
- M** = Bending Moment

Design Service

Available at no charge to the specifying architect/engineer or fabricator, is access to a computer program which provides uniform load and deflection (actual or fraction of span) analysis of grating products. Just call, write or fax your design criteria – loading, span, allowable deflection, or grating size desired – and we will provide you with the information you require.

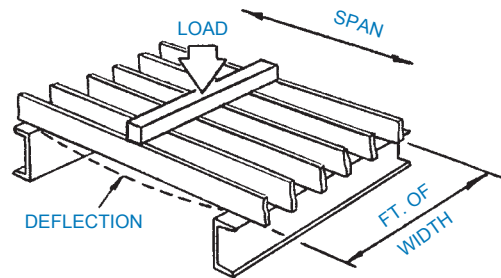
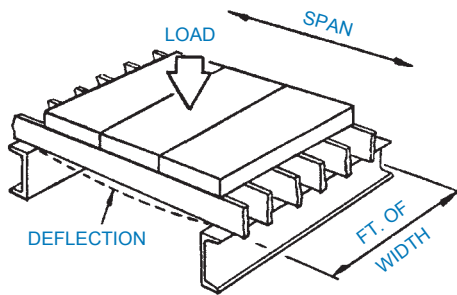

	Uniform Load	Concentrated Load
Step 1. Determine M:	$M = \frac{FS}{12}$	$M = \frac{FS}{12}$
Step 2. Determine U or C:	$U = \frac{8M}{L^2}$	$C = \frac{4M}{L}$
Step 3. Check D*:	$D = \frac{5UL (L \times 12)^3}{384 EI}$	$D = \frac{C (L \times 12)^3}{48 EI}$

*Deflection should be limited to 1/4" under 100# uniform load to afford pedestrian comfort.

Light Duty Steel Grating is best suited for use in conjunction with pedestrian traffic, and for very light, rubber pneumatic tired rolling traffic (carts, dollies and hand trucks). For other rolling loads (forklifts, cars, trucks, etc.) see the Heavy Duty Steel Grating section, page 66.

Information of a technical nature contained herein is intended only for evaluation by technically skilled persons, with any use thereof to be at their independent discretion and risk. Such information is reliable when evaluated in the proper manner under conditions as described herein. Ohio Gratings, Inc. shall have no responsibility or liability for results obtained or damages resulting from improper evaluation or use.

LIGHT DUTY WELDED STEEL



W SERIES



Light duty steel grating is the workhorse of the industrial flooring market and is used for many different types of pedestrian (walking) applications. The open grid construction provides maximum passage for light, air circulation and drainage.

Electro-forging, a machine process combining hydraulic pressure and heat fusion, is readily available and an economical method for manufacturing steel grating panels. The bearing bar surface can be ordered smooth or with a serrated surface for maximum skid

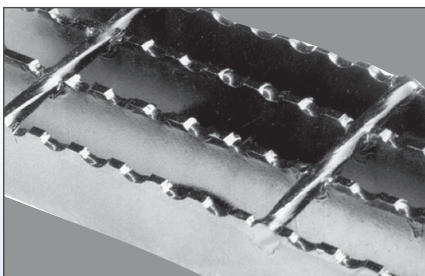

resistance. Also available in Stainless Steel, type 304 or 316, upon request. OnGrip® Spray Traction Surface is also available.

◀ **Serrated surface also available.**

GRATING PROFILES AVAILABLE...

W SERIES Light Duty Welded Steel

All profiles shown below are also available with 2" cross bar centers. Product numbers would be 19-W-2, 15-W-2 and 11-W-2

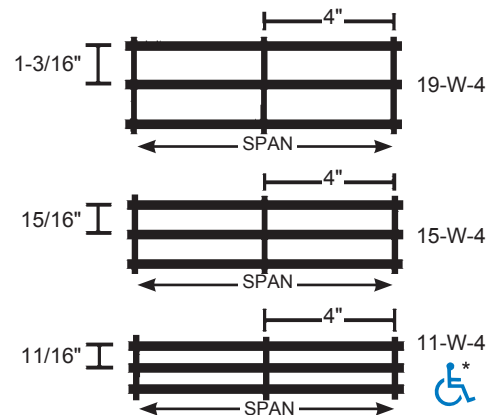

See load tables beginning on page 45.

*Note: Conforms with the spacing requirements of ADA (September 2010) when installed with the elongated opening perpendicular to the dominant direction of travel. See ADA Guidelines

LIGHT DUTY STEEL DOVE TAIL



DT SERIES

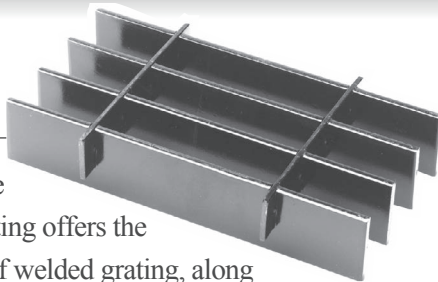

Traditionally designed, Dove Tail slot pressure locked grating offers the high strength and stiffness of welded grating, along with the smooth, clean lines of a flush top rectangular cross bar. Bearing bars and cross bars are precision slotted, assembled in egg-crate fashion and hydraulically pressed together to form a tightly locked, rigidly stable panel grid. This grating is available in a wide variety of spacings including a 1/4" or 1/2" opening product, which conforms with provisions for the "Americans with Disabilities Act" (September 2010). These products are part of our Grater Access line and are available with cross bars on 2" or 4" centers. This is also a popular style in the architectural community because of the aesthetic eye appeal of the product and the ability to maintain tighter tolerances. This style is also available in stainless steel. OnGrip® Spray Traction Surface is also available.

Serrated surface also available.

***8 Space available upon request.**

GRATING PROFILES AVAILABLE...

DT SERIES Light Duty Steel Dove Tail

All profiles shown below are also available with 2" cross bar centers. Product numbers would be 19-DT-2, 15-DT-2, 11-DT-2 and 7-DT-2

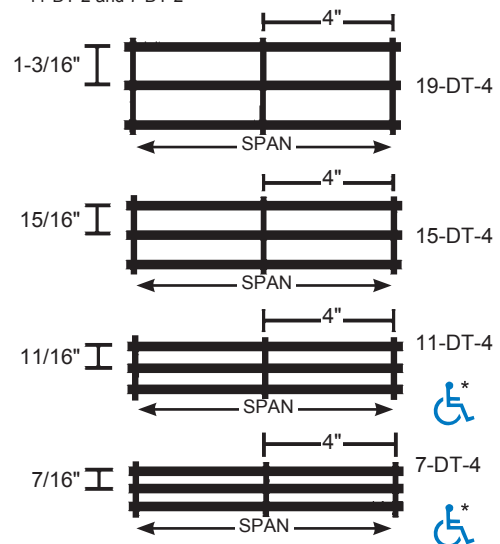

See load tables beginning on page 45.

***Note:** Conforms with the spacing requirements of ADA (September 2010) when installed with the elongated opening perpendicular to the dominant direction of travel. See ADA Guidelines

LIGHT DUTY SWAGED CARBON STEEL



SGCS SERIES



The swaging process allows the assembly of bar grating panels by mechanically locking the cross bars at right angles to the bearing bars. It provides the clean crisp lines of a recessed cross bar and eliminates the jagged weld flash inherent with welded bar grating. Additionally, the heat generated as part of the electro-forging process, limits how close together the bars may be placed. By using the most modern technology available, swaged bar grating is available in a wide variety of spacings including a 1/4" or 1/2" opening product, which conforms with provisions for the "Americans with Disabilities Act" (September 2010). Because of its aesthetic appeal and the ability to meet tight tolerances, this product is often used for architectural applications.

OnGrip® Spray Traction Surface is also available.

***8 Space available upon request.**

GRATING PROFILES AVAILABLE... SGCS SERIES Light Duty Swaged Carbon Steel

All profiles shown below are also available with 2" cross bar centers. Product numbers would be 19-SGCS-2, 15-SGCS-2, 11-SGCS-2 and 7-SGCS-2

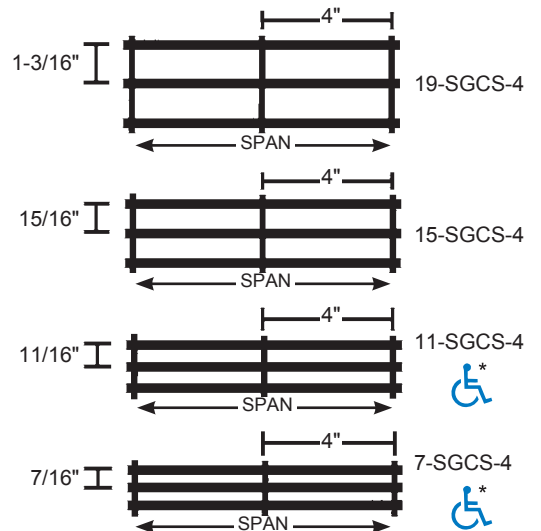

See load tables beginning on page 45.

***Note:** Conforms with the spacing requirements of ADA (September 2010) when installed with the elongated opening perpendicular to the dominant direction of travel. See ADA Guidelines

19 SPACE PROFILES

STEEL LIGHT DUTY WELDED

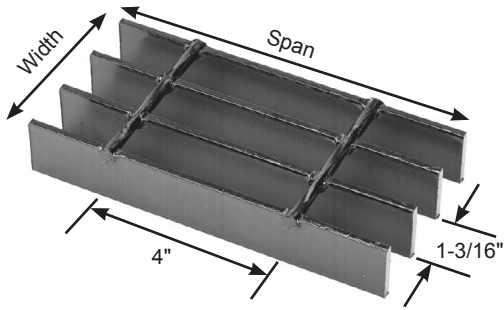

19-W-4

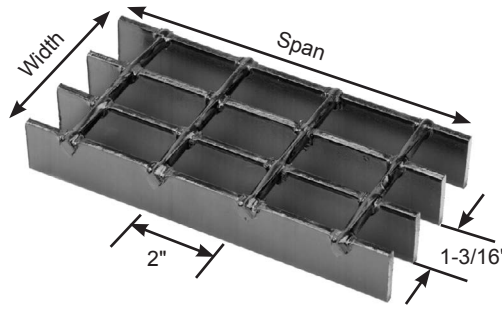

19-W-2

% Open Area*		
Bars	1/8"	3/16"
4" cc	83%	77%
2" cc	76%	71%

STEEL LIGHT DUTY DOVE TAIL

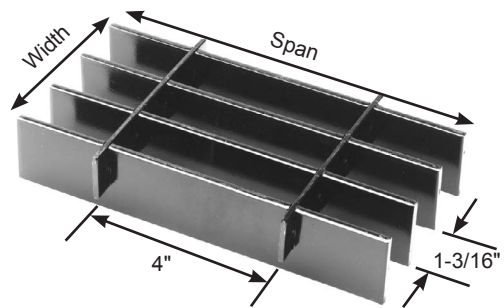

19-DT-4

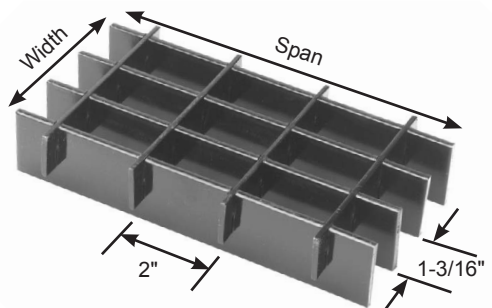

19-DT-2

% Open Area*		
Bars	1/8"	3/16"
4" cc	86%	81%
2" cc	84%	79%

STEEL LIGHT DUTY SWAGED CARBON

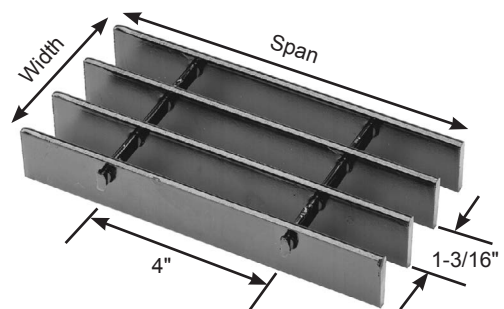

19-SGCS-4

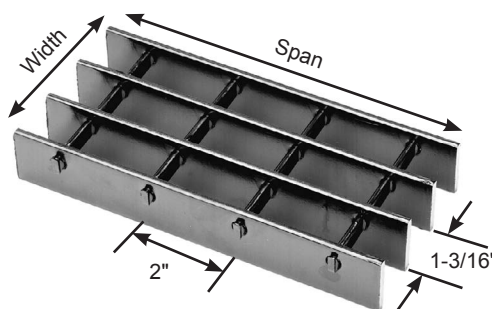

19-SGCS-2

% Open Area*		
Bars	1/8"	3/16"
4" cc	83%	78%
2" cc	76%	72%

19 SPACE LOAD TABLES

Light Duty Welded, Light Duty Dove Tail & Light Duty Swaged Carbon Steel

Bar Size, Inches	Ped Span, Inches	Wt.* Lbs. Sq. Ft.	Sec. Prop Sx*, in ³ lx*, in ³	Clear Span															
				2'- 0"	2'- 6"	3'- 0"	3'- 6"	4'- 0"	4'- 6"	5'- 0"	5'- 6"	6'- 0"	6'- 6"	7'- 0"	8'- 0"				
3/4 x 3/16	46	5.43	0.178	U	533	341	237	174	133										
				D	0.099	0.155	0.224	0.304	0.397										
				0.067	C	533	426	355	305	266									
1 x 1/8	51	4.88	0.211	U	632	404	281	206	158	125									
				D	0.075	0.116	0.168	0.228	0.298	0.378									
				0.105	C	632	505	421	361	316	281								
1 x 3/16	57	7.04	0.316	U	947	606	421	309	237	187	152								
				D	0.074	0.116	0.168	0.228	0.298	0.377	0.467								
				0.158	C	947	758	632	541	474	421	379							
1-1/4 x 1/8	61	5.96	0.329	U	987	632	439	322	247	195	158	130							
				D	0.060	0.093	0.134	0.182	0.239	0.302	0.373	0.449							
				0.206	C	987	789	658	564	493	439	395	359						
1-1/4 x 3/16	67	8.64	0.493	U	1480	947	658	483	370	292	237	196	164						
				D	0.060	0.093	0.134	0.182	0.238	0.301	0.373	0.451	0.535						
				0.308	C	1480	1184	987	846	740	658	592	538	493					
1-1/2 x 1/8	70	7.04	0.474	U	1421	909	632	464	355	281	227	188	158						
				D	0.050	0.078	0.112	0.152	0.198	0.252	0.310	0.376	0.447						
				0.355	C	1421	1137	947	812	711	632	568	517	474					
1-1/2 x 3/16	77	10.25	0.711	U	2132	1364	947	696	533	421	341	282	237	202					
				D	0.050	0.078	0.112	0.152	0.199	0.251	0.310	0.376	0.447	0.525					
				0.533	C	2132	1705	1421	1218	1066	947	853	775	711	656				
1-3/4 x 3/16	87	11.87	0.967	U	2901	1857	1289	947	725	573	464	384	322	275	237	181			
				D	0.043	0.067	0.096	0.130	0.170	0.215	0.266	0.322	0.383	0.450	0.522	0.680			
				0.846	C	2901	2321	1934	1658	1451	1289	1160	1055	967	893	829	725		
2 x 3/16	96	13.48	1.263	U	3789	2425	1684	1237	947	749	606	501	421	359	309	237			
				D	0.037	0.058	0.084	0.114	0.149	0.189	0.233	0.282	0.335	0.394	0.456	0.596			
				1.263	C	3789	3032	2526	2165	1895	1684	1516	1378	1263	1166	1083	947		
2-1/4 x 3/16	105	15.08	1.599	U	4796	3069	2132	1566	1199	947	767	634	533	454	392	300			
				D	0.033	0.052	0.074	0.101	0.132	0.168	0.207	0.250	0.298	0.350	0.406	0.530			
				1.798	C	4796	3837	3197	2741	2398	2132	1918	1744	1599	1476	1370	1199		
2-1/2 x 3/16	113	16.70	1.974	U	5921	3789	2632	1933	1480	1170	947	783	658	561	483	370			
				D	0.030	0.047	0.067	0.091	0.119	0.151	0.186	0.225	0.268	0.315	0.365	0.477			
				2.467	C	5921	4737	3947	3383	2960	2632	2368	2153	1974	1822	1692	1480		
				D	0.024	0.037	0.054	0.073	0.095	0.121	0.149	0.180	0.215	0.252	0.292	0.381			

U - Safe uniform load in pounds/sq. ft.
 C - Safe concentrated load in pounds/ft. grating width
 D - Deflection in inches

Loads and deflections given in this table are theoretical, and based on a unit stress of 18,000 psi.

*Based on 10.105 bars/ft. of grating width. Bearing bars 1-3/16" c.c. Add .6 lbs./sq. ft. for 19-SGCS-2. Note: Grating for spans to the left of the heavy line have a deflection less than 1/4" for uniform loads of 100 lbs./sq. ft. This is the maximum deflection to afford pedestrian comfort and can be exceeded for other types of load at the discretion of the engineer. The actual Ped (pedestrian) Span under this condition is shown above for each size of grating. When serrated grating is specified, the depth of grating required for a specific load will be 1/4" greater than that shown in these tables. 3/4" x 3/16" serrated grating is not available.

Panel Width Chart (in.) - 19-W-4, 19-W-2, 19-DT-4, 19-DT-2, 19-SGCS-4 & 19-SGCS-2 Dimensions Are Out-to-Out of Bearing Bars**

No. of Bars	2	3	4	5	6	7	8	9	10	11	12	13	14	15	16
3/16" Bars	1-3/8	2-9/16	3-3/4	4-15/16	6-1/8	7-5/16	8-1/2	9-11/16	10-7/8	12-1/16	13-1/4	14-7/16	15-5/8	16-13/16	18
No. of Bars	17	18	19	20	21	22	23	24	25	26	27	28	29	30	31
3/16" Bars	19-3/16	20-3/8	21-9/16	22-3/4	23-15/16	25-1/8	26-5/16	27-1/2	28-11/16	29-7/8	31-1/16	32-1/4	33-7/16	34-5/8	35-13/16

**Add 1/4" for extended cross bars. Deduct 1/16" for 1/8" bearing bars. Standard panel widths indicated in blue.

15 SPACE PROFILES

STEEL LIGHT DUTY WELDED

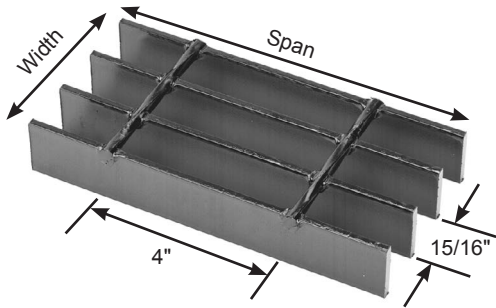

15-W-4

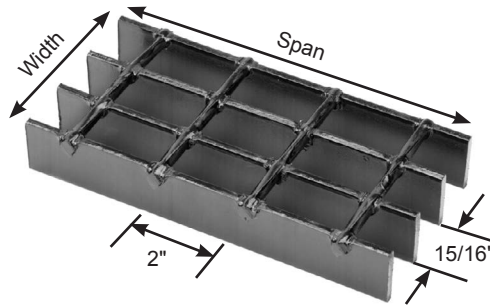

15-W-2

% Open Area*	
4" cc	73%
2" cc	67%

STEEL LIGHT DUTY DOVE TAIL

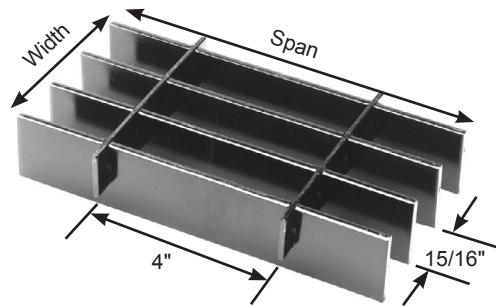

15-DT-4

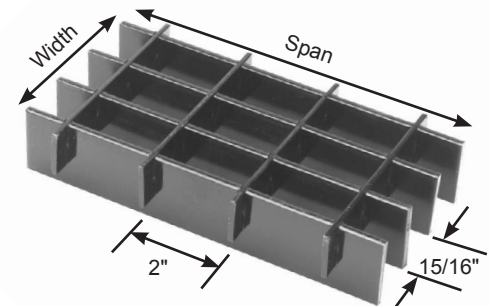

15-DT-2

% Open Area*	
4" cc	77%
2" cc	75%

STEEL LIGHT DUTY SWAGED CARBON

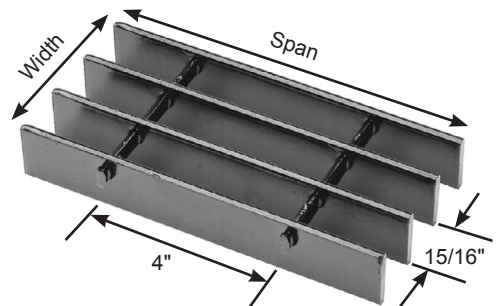

15-SGCS-4

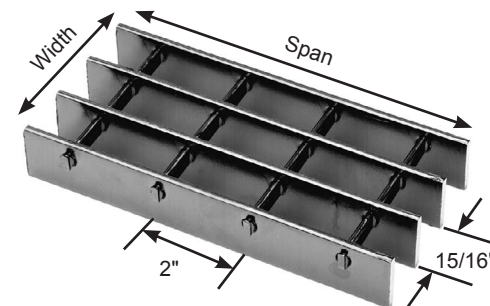

15-SGCS-2

% Open Area*	
4" cc	74%
2" cc	68%

15 SPACE LOAD TABLES

Light Duty Welded, Light Duty Dove Tail & Light Duty Swaged Carbon Steel

Bar Size, Inches	Ped Span, Inches	Wt. Lbs. Sq. Ft.	Sec. Prop Sx*, in ³ Ix*, in ⁴	Clear Span												
				2'- 0"	2'- 6"	3'- 0"	3'- 6"	4'- 0"	4'- 6"	5'- 0"	5'- 6"	6'- 0"	6'- 6"	7'- 0"	8'- 0"	
3/4 x 3/16	49	7.11	0.225	U	675	432	300	220	169	133	U - Safe uniform load in pounds/sq. ft. C - Safe concentrated load in pounds/ft. grating width D - Deflection in inches					
				D	0.099	0.155	0.223	0.304	0.398	0.502						
			0.084	C	675	540	450	386	338	300						
				D	0.079	0.124	0.179	0.243	0.318	0.402						
1 x 3/16	60	9.27	0.400	U	1200	768	533	392	300	237	192	159	Loads and deflections given in this table are theoretical, and are based on a unit stress of 18,000 psi.			
				D	0.074	0.116	0.167	0.228	0.298	0.377	0.466	0.564				
			0.200	C	1200	960	800	686	600	533	480	436				
				D	0.060	0.093	0.134	0.183	0.238	0.301	0.372	0.450				
1-1/4 x 3/16	71	11.43	0.625	U	1875	1200	833	612	469	370	300	248	208			
				D	0.060	0.093	0.134	0.182	0.238	0.301	0.372	0.451	0.535			
			0.391	C	1875	1500	1250	1071	938	833	750	682	625			
				D	0.048	0.074	0.107	0.146	0.191	0.241	0.298	0.361	0.429			
1-1/2 x 3/16	82	13.82	0.900	U	2700	1728	1200	882	675	533	432	357	300	256	220	
				D	0.050	0.078	0.112	0.152	0.199	0.251	0.310	0.375	0.447	0.525	0.607	
			0.675	C	2700	2160	1800	1543	1350	1200	1080	982	900	831	771	
				D	0.040	0.062	0.089	0.122	0.159	0.201	0.248	0.300	0.358	0.420	0.486	
1-3/4 x 3/16	92	15.98	1.225	U	3675	2352	1633	1200	919	726	588	486	408	348	300	230
				D	0.043	0.067	0.096	0.130	0.170	0.215	0.266	0.322	0.383	0.450	0.521	0.682
			1.072	C	3675	2940	2450	2100	1838	1633	1470	1336	1225	1131	1050	919
				D	0.034	0.053	0.077	0.104	0.136	0.172	0.213	0.257	0.306	0.360	0.417	0.545
2 x 3/16	102	18.14	1.600	U	4800	3072	2133	1567	1200	948	768	635	533	454	392	300
				D	0.037	0.058	0.084	0.114	0.149	0.189	0.233	0.282	0.335	0.393	0.456	0.596
			1.600	C	4800	3840	3200	2743	2400	2133	1920	1745	1600	1477	1371	1200
				D	0.030	0.047	0.067	0.091	0.119	0.151	0.186	0.225	0.268	0.315	0.365	0.477
2-1/4 x 3/16	111	20.16	2.025	U	6075	3888	2700	1984	1519	1200	972	803	675	575	496	380
				D	0.033	0.052	0.074	0.101	0.132	0.168	0.207	0.250	0.298	0.350	0.406	0.530
			2.278	C	6075	4860	4050	3471	3038	2700	2430	2209	2025	1869	1736	1519
				D	0.026	0.041	0.060	0.081	0.106	0.134	0.166	0.200	0.238	0.280	0.324	0.424
2-1/2 x 3/16	120	22.32	2.500	U	7500	4800	3333	2449	1875	1481	1200	992	833	710	612	469
				D	0.030	0.047	0.067	0.091	0.119	0.151	0.186	0.225	0.268	0.315	0.365	0.477
			3.125	C	7500	6000	5000	4286	3750	3333	3000	2727	2500	2308	2143	1875
				D	0.024	0.037	0.054	0.073	0.095	0.121	0.149	0.180	0.215	0.252	0.292	0.381

*Based on 12.8 bars/ft. of grating width. Bearing bars 15/16" c.c. Add .8 lbs./sq. ft. for 15-W-2, 1/8" bearing bars available by inquiry. **Note:** Grating for spans to the left of the heavy line have a deflection less than 1/4" for uniform loads of 100 lbs./sq. ft. This is the maximum deflection to afford pedestrian comfort and can be exceeded for other types of load at the discretion of the engineer. The actual Ped (pedestrian) Span under this condition is shown above for each size of grating. When serrated grating is specified, the depth of grating required for a specific load will be 1/4" greater than that shown in these tables. 3/4" x 3/16" serrated grating is not available.

Panel Width Chart (in.) - 15-W-4, 15-W-2, 15-DT-4, 15-DT-2, 15-SGCS-4 & 15-SGCS-2 Dimensions Are Out-to-Out of Bearing Bars**

No. of Bars	2	3	4	5	6	7	8	9	10	11	12	13	14	15	16
3/16" Bars	1-1/8	2-1/16	3	3-15/16	4-7/8	5-13/16	6-3/4	7-11/16	8-5/8	9-9/16	10-1/2	11-7/16	12-3/8	13-5/16	14-1/4
No. of Bars	17	18	19	20	21	22	23	24	25	26	27	28	29	30	31
3/16" Bars	15-3/16	16-1/8	17-1/16	18	18-15/16	19-7/8	20-13/16	21-3/4	22-11/16	23-5/8	24-9/16	25-1/2	26-7/16	27-3/8	28-5/16
No. of Bars	32	33	34	35	36	37	38	39							
3/16" Bars	29-1/4	30-3/16	31-1/8	32-1/16	33	33-15/16	34-7/8	35-13/16							

**Add 1/4" for extended cross bars. Deduct 1/16" for 1/8" bearing bars. Standard panel widths indicated in blue.

11 SPACE PROFILES

STEEL LIGHT DUTY WELDED

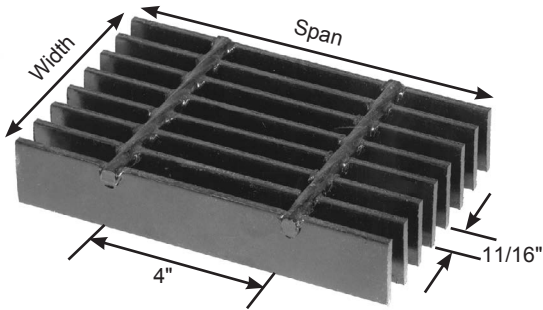

11-W-4

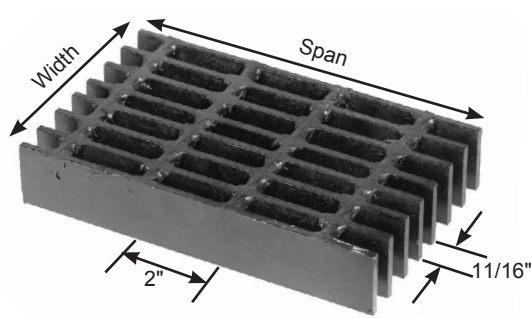

11-W-2

% Open Area*	
4" cc	66%
2" cc	57%

STEEL LIGHT DUTY DOVE TAIL

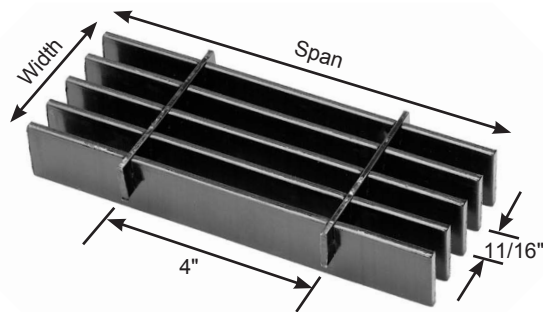

11-DT-4

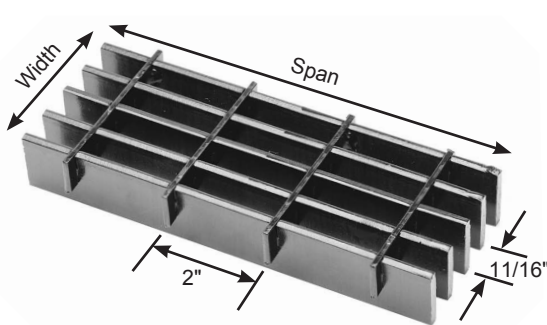

11-DT-2

% Open Area*	
4" cc	70%
2" cc	68%

STEEL LIGHT DUTY SWAGED CARBON

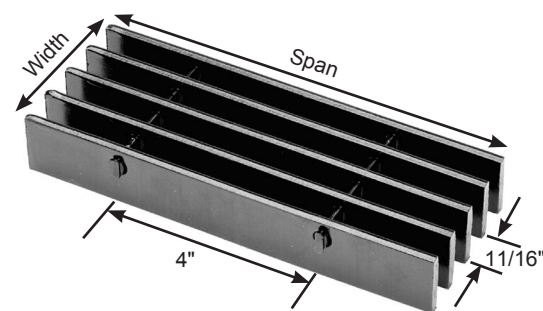

11-SGCS-4

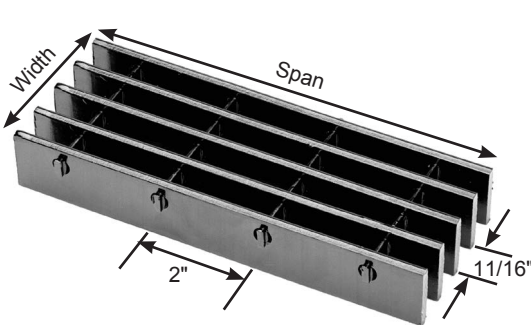

11-SGCS-2

% Open Area*	
4" cc	67%
2" cc	62%

11 SPACE LOAD TABLES

Light Duty Welded, Light Duty Dove Tail & Light Duty Swaged Carbon Steel

Bar Size, Inches	Ped Span, Inches	Wt. Lbs. Sq. Ft.	Sec. Prop Sx*, in ² lx*, in ⁴	ClearSpan												
				2'- 0"	2'- 6"	3'- 0"	3'- 6"	4'- 0"	4'- 6"	5'- 0"	5'- 6"	6'- 0"	6'- 6"	7'- 0"	8'- 0"	
3/4 x 3/16	53	9.28	0.307	U	920	589	409	301	230	182	U - Safe uniform load in pounds/sq. ft. C - Safe concentrated load in pounds/ft. grating width D - Deflection in inches % Open Area* 4" cc 66% 2" cc 57%					
				D	0.099	0.155	0.223	0.305	0.397	0.503						
			0.115	C	920	736	614	526	460	409						
				D	0.079	0.124	0.179	0.243	0.318	0.402						
1 x 3/16	65	12.16	0.545	U	1636	1047	727	534	409	323	262	216	Loads and deflections are theoretical and based on a unit stress of 18,000 psi.			
				D	0.074	0.116	0.168	0.228	0.298	0.377	0.466	0.562				
			0.273	C	1636	1309	1091	935	818	727	655	595				
				D	0.060	0.093	0.134	0.182	0.238	0.302	0.373	0.451				
1-1/4 x 3/16	77	15.04	0.852	U	2557	1636	1136	835	639	505	409	338	284	242		
				D	0.060	0.093	0.134	0.183	0.238	0.302	0.372	0.450	0.536	0.629		
			0.533	C	2557	2046	1705	1461	1278	1136	1023	930	852	787		
				D	0.048	0.075	0.107	0.146	0.191	0.241	0.298	0.361	0.429	0.504		
1-1/2 x 3/16	89	18.28	1.227	U	3682	2356	1636	1202	920	727	589	487	409	349	301	230
				D	0.050	0.078	0.112	0.152	0.199	0.251	0.310	0.376	0.447	0.525	0.609	0.794
			0.920	C	3682	2946	2455	2104	1841	1636	1473	1339	1227	1133	1052	920
				D	0.040	0.062	0.089	0.122	0.159	0.201	0.248	0.300	0.357	0.420	0.487	0.635
1-3/4 x 3/16	99	21.16	1.670	U	5011	3207	2227	1636	1253	990	802	663	557	474	409	313
				D	0.043	0.066	0.096	0.130	0.170	0.215	0.266	0.322	0.383	0.449	0.521	0.681
			1.462	C	5011	4009	3341	2864	2506	2227	2005	1822	1670	1542	1432	1253
				D	0.034	0.053	0.077	0.104	0.136	0.172	0.213	0.257	0.306	0.360	0.417	0.545
2 x 3/16	110	24.04	2.182	U	6546	4189	2909	2137	1636	1293	1047	866	727	620	534	409
				D	0.037	0.058	0.084	0.114	0.149	0.189	0.233	0.282	0.335	0.394	0.456	0.596
			2.182	C	6546	5237	4364	3740	3273	2909	2618	2380	2182	2014	1870	1636
				D	0.030	0.047	0.067	0.091	0.119	0.151	0.186	0.225	0.268	0.315	0.365	0.477
2-1/4 x 3/16	120	26.74	2.761	U	8284	5302	3682	2705	2071	1636	1325	1095	920	784	676	518
				D	0.033	0.052	0.074	0.101	0.132	0.168	0.207	0.250	0.298	0.350	0.405	0.530
			3.107	C	8284	6627	5523	4734	4142	3682	3314	3012	2761	2549	2367	2071
				D	0.026	0.041	0.060	0.081	0.106	0.134	0.166	0.200	0.238	0.280	0.324	0.424
2-1/2 x 3/16	130	29.62	3.409	U	10228	6546	4546	3340	2557	2020	1636	1352	1136	968	835	639
				D	0.030	0.047	0.067	0.091	0.119	0.151	0.186	0.225	0.268	0.315	0.365	0.477
			4.261	C	10228	8182	6818	5844	5114	4546	4091	3719	3409	3147	2922	2557
				D	0.024	0.037	0.054	0.073	0.095	0.121	0.149	0.180	0.214	0.252	0.292	0.381

*Based on 17.455 bars/ft. of grating width. Bearing bars 11/16" c.c. Add .8 lbs./sq. ft. for 11-W-2, 1/8" bearing bars available by inquiry. **Note:** Grating for spans to the left of the heavy line have a deflection less than 1/4" for uniform loads of 100 lbs./sq. ft. This is the maximum deflection to afford pedestrian comfort and can be exceeded for other types of load at the discretion of the engineer. The actual Ped (pedestrian) Span under this condition is shown above for each size of grating. When serrated grating is specified, the depth of grating required for a specific load will be 1/4" greater than that shown in these tables. 3/4" x 3/16" serrated grating is not available.

Panel Width Chart (in.) - 11-W-4 & 11-W-2 Dimensions Are Out-to-Out of Bearing Bars**

No. of Bars	2	3	4	5	6	7	8	9	10	11	12	13	14	15	16
3/16" Bars	7/8	1-9/16	2-1/4	2-15/16	3-5/8	4-5/16	5	5-11/16	6-3/8	7-1/16	7-3/4	8-7/16	9-1/8	9-13/16	10-1/2
No. of Bars	17	18	19	20	21	22	23	24	25	26	27	28	29	30	31
3/16" Bars	11-3/16	11-7/8	12-9/16	13-1/4	13-15/16	14-5/8	15-5/16	16	16-11/16	17-3/8	18-1/16	18-3/4	19-7/16	20-1/8	20-13/16
No. of Bars	32	33	34	35											
3/16" Bars	21-1/2	22-3/16	22-7/8	23-9/16											

**Deduct 1/16" for 1/8" bearing bars. Standard panel widths indicated in blue.

Panel Width Chart (in.) - 11-SGCS-4, 11-SGCS-2, 11-DT-4 & 11-DT-2 Dimensions Are Out-to-Out of Bearing Bars**

No. of Bars	2	3	4	5	6	7	8	9	10	11	12	13	14	15	16
3/16" Bars	7/8	1-9/16	2-1/4	2-15/16	3-5/8	4-5/16	5	5-11/16	6-3/8	7-1/16	7-3/4	8-7/16	9-1/8	9-13/16	10-1/2
No. of Bars	17	18	19	20	21	22	23	24	25	26	27	28	29	30	31
3/16" Bars	11-3/16	11-7/8	12-9/16	13-1/4	13-15/16	14-5/8	15-5/16	16	16-11/16	17-3/8	18-1/16	18-3/4	19-7/16	20-1/8	20-13/16
No. of Bars	32	33	34	35	36	37	38	39	40	41	42	43	44	45	46
3/16" Bars	21-1/2	22-3/16	22-7/8	23-9/16	24-1/4	24-15/16	25-5/8	26-5/16	27	27-11/16	28-3/8	29-1/16	29-3/4	30-7/16	31-1/8
No. of Bars	47	48	49	50	51	52	53								
3/16" Bars	31-13/16	32-1/2	33-3/16	33-7/8	34-9/16	35-1/4	35-15/16								

**Add 1/4" for extended cross bars. Deduct 1/16" for 1/8" bearing bars. Standard panel widths indicated in blue.

7 SPACE PROFILES

STEEL LIGHT DUTY DOVE TAIL

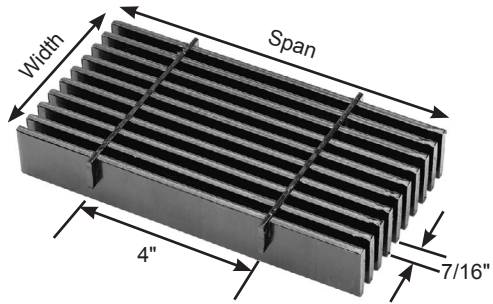

7-DT-4

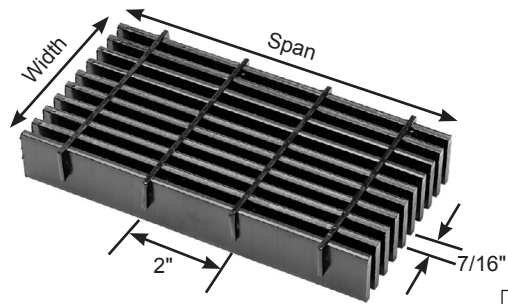

7-DT-2

% Open Area*	
4" cc	55%
2" cc	53%

STEEL LIGHT DUTY SWAGED CARBON

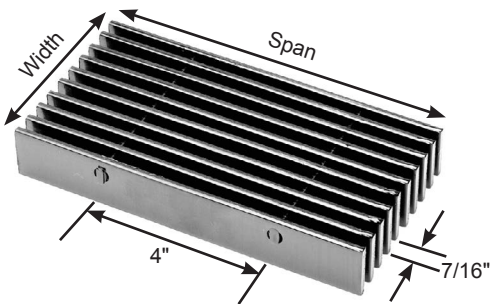

7-SGCS-4

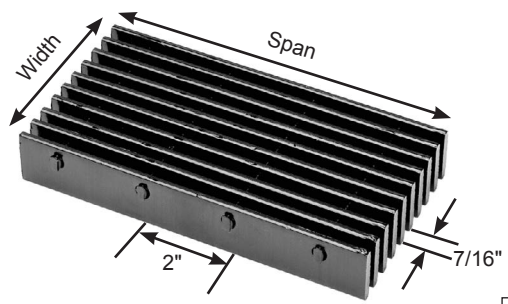

7-SGCS-2

% Open Area*	
4" cc	52%
2" cc	48%

7 SPACE LOAD TABLES

Light Duty Dove Tail & Light Duty Swaged Carbon Steel

Bar Size, Inches	Ped Span, Inches	Wt.* Lbs. Sq. Ft.	Sec. Prop Sx*, in ³ lx*, in ⁴	ClearSpan																		
				2'- 0"	2'- 6"	3'- 0"	3'- 6"	4'- 0"	4'- 6"	5'- 0"	5'- 6"	6'- 0"	6'- 6"	7'- 0"	8'- 0"							
3/4 x 3/16	59	13.73	0.482	U	1446	926	643	472	362	286	231	U - Safe uniform load in pounds/sq. ft. C - Safe concentrated load in pounds/ft. grating width D - Deflection in inches Loads and deflections are theoretical and based on a unit stress of 18,000 psi.										
				D	0.099	0.155	0.223	0.304	0.398	0.503	0.620											
				C	1446	1157	964	827	723	643	579											
			0.181	D	0.079	0.124	0.179	0.243	0.318	0.402	0.497											
				U	2571	1646	1143	840	643	508	411	340	286	<table border="1"> <tr> <td colspan="2">% Open Area*</td> </tr> <tr> <td>4" cc</td> <td>52%</td> </tr> <tr> <td>2" cc</td> <td>48%</td> </tr> </table>			% Open Area*		4" cc	52%	2" cc	48%
				% Open Area*																		
4" cc	52%																					
2" cc	48%																					
C	2571	2057	1714	1469	1286	1143	1029	935	857													
1 x 3/16	73	18.09	0.857	U	5786	4629	3857	3306	2893	2571	2314	2104	1929	1780	1653	1446						
				D	0.074	0.116	0.168	0.228	0.298	0.377	0.465	0.563	0.671									
				C	5786	4629	3857	3306	2893	2571	2314	2104	1929	1780	1653	1446						
			0.429	D	0.060	0.093	0.134	0.182	0.238	0.302	0.373	0.451	0.536									
				U	4018	2571	1786	1312	1004	794	643	531	446	380	328	251						
				D	0.060	0.093	0.134	0.182	0.238	0.302	0.372	0.450	0.536	0.629	0.730	0.953						
1-1/4 x 3/16	86	22.45	1.339	C	4018	3214	2679	2296	2009	1786	1607	1461	1339	1236	1148	1004						
				D	0.048	0.074	0.107	0.146	0.191	0.241	0.298	0.360	0.429	0.503	0.584	0.762						
				U	5786	3703	2571	1889	1446	1143	926	765	643	548	472	362						
			0.837	D	0.050	0.078	0.112	0.152	0.199	0.251	0.310	0.375	0.447	0.525	0.608	0.795						
				C	5786	4629	3857	3306	2893	2571	2314	2104	1929	1780	1653	1446						
				D	0.040	0.062	0.089	0.122	0.159	0.201	0.248	0.300	0.358	0.420	0.487	0.635						
1-3/4 x 3/16	111	31.20	2.625	U	7875	5040	3500	2571	1969	1556	1260	1041	875	746	643	492						
				D	0.043	0.067	0.096	0.130	0.170	0.216	0.266	0.322	0.383	0.450	0.521	0.681						
				C	7875	6300	5250	4500	3938	3500	3150	2864	2625	2423	2250	1969						
			2.297	D	0.034	0.053	0.077	0.104	0.136	0.172	0.213	0.258	0.306	0.360	0.417	0.545						
				U	10286	6583	4572	3359	2571	2032	1646	1360	1143	974	840	643						
				D	0.037	0.058	0.084	0.114	0.149	0.189	0.233	0.282	0.335	0.393	0.456	0.596						
2 x 3/16	123	35.59	3.429	C	10286	8229	6857	5878	5143	4572	4114	3740	3429	3165	2939	2571						
				D	0.030	0.047	0.067	0.091	0.119	0.151	0.186	0.225	0.268	0.315	0.365	0.477						
				U	13018	8332	5786	4251	3255	2571	2083	1721	1446	1232	1063	814						
			4.339	D	0.033	0.052	0.074	0.101	0.132	0.168	0.207	0.250	0.298	0.350	0.406	0.530						
				C	13018	10414	8679	7439	6509	5786	5207	4734	4339	4006	3719	3255						
				D	0.026	0.041	0.060	0.081	0.106	0.134	0.166	0.200	0.238	0.280	0.324	0.424						
2-1/4 x 3/16	134	39.92	4.882	U	16072	10286	7143	5248	4018	3175	2571	2125	1786	1522	1312	1004						
				D	0.030	0.047	0.067	0.091	0.119	0.151	0.186	0.225	0.268	0.315	0.365	0.476						
				C	16072	12857	10714	9184	8036	7143	6429	5844	5357	4945	4592	4018						
			5.357	D	0.024	0.037	0.054	0.073	0.095	0.121	0.149	0.180	0.215	0.252	0.292	0.381						
				U	16072	10286	7143	5248	4018	3175	2571	2125	1786	1522	1312	1004						
				D	0.030	0.047	0.067	0.091	0.119	0.151	0.186	0.225	0.268	0.315	0.365	0.476						
2-1/2 x 3/16	145	44.31	6.697	C	16072	12857	10714	9184	8036	7143	6429	5844	5357	4945	4592	4018						
				D	0.024	0.037	0.054	0.073	0.095	0.121	0.149	0.180	0.215	0.252	0.292	0.381						
				U	16072	10286	7143	5248	4018	3175	2571	2125	1786	1522	1312	1004						

*Based on 27.429 bars/ft. of grating width. Bearing bars 7/16" c.c. Add .6 lbs./sq. ft. for 7-SGCS-2. 1/8" bearing bars available by inquiry. **Note:** Grating for spans to the left of the heavy line have a deflection less than 1/4" for uniform loads of 100 lbs./sq. ft. This is the maximum deflection to afford pedestrian comfort and can be exceeded for other types of load at the discretion of the engineer. The actual Ped (pedestrian) Span under this condition is shown above for each size of grating. When serrated grating is specified, the depth of grating required for a specific load will be 1/4" greater than that shown in these tables. 3/4" x 3/16" serrated grating is not available.

Panel Width Chart (in.) - 7-SGCS-4, 7-SGCS-2, 7-DT-4 & 7-DT-2 Dimensions Are Out-to-Out of Bearing Bars**

No. of Bars	2	3	4	5	6	7	8	9	10	11	12	13	14	15	16
3/16" Bars	5/8	1-1/16	1-1/2	1-15/16	2-3/8	2-13/16	3-1/4	3-11/16	4-1/8	4-9/16	5	5-7/16	5-7/8	6-5/16	6-3/4
No. of Bars	17	18	19	20	21	22	23	24	25	26	27	28	29	30	31
3/16" Bars	7-3/16	7-5/8	8-1/16	8-1/2	8-15/16	9-3/8	9-13/16	10-1/4	10-11/16	11-1/8	11-9/16	12	12-7/16	12-7/8	13-5/16
No. of Bars	32	33	34	35	36	37	38	39	40	41	42	43	44	45	46
3/16" Bars	13-3/4	14-3/16	14-5/8	15-1/16	15-1/2	15-15/16	16-3/8	16-13/16	17-1/4	17-11/16	18-1/8	18-9/16	19	19-7/16	19-7/8
No. of Bars	47	48	49	50	51	52	53	54	55	56	57	58	59	60	61
3/16" Bars	20-5/16	20-3/4	21-3/16	21-5/8	22-1/16	22-1/2	22-15/16	23-3/8	23-13/16	24-1/4	24-11/16	25-1/8	25-9/16	26	26-7/16
No. of Bars	62	63	64	65	66	67	68	69	70	71	72	73	74	75	76
3/16" Bars	26-7/8	27-5/16	27-3/4	28-3/16	28-5/8	29-1/16	29-1/2	29-15/16	30-3/8	30-13/16	31-1/4	31-11/16	32-1/8	32-9/16	33
No. of Bars	77	78	79	80	81	82	83								
3/16" Bars	33-7/16	33-7/8	34-5/16	34-3/4	35-3/16	35-5/8	36-1/16								

**Add 1/4" for extended cross bars. Deduct 1/16" for 1/8" bearing bars. Standard panel widths indicated in blue.

LIGHT DUTY RIVETED STEEL



R SERIES



Riveted grating is the oldest style of industrial footwalk, but still the choice of many engineers due to its ruggedness, reliability and durability. This grating is composed of straight bearing bars, and bent connecting bars, which are joined at their contact points by rivets. Since the connecting bars extend continuously between bearing bars along the grating spans, they not only serve to join the bearing bars together, but also contribute to the load carrying capability and lateral stability of the grating panels. This added dimension makes riveted grating an ideal

choice where high strength and stiffness are required. OnGrip® Spray Traction Surface is also available.

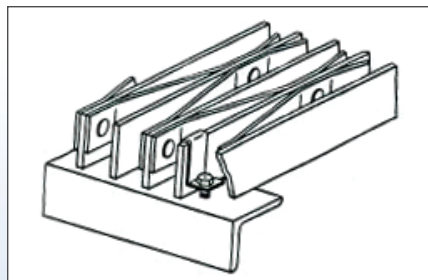

◀ **Z Clips manufactured from stainless steel. Available in 1", 1-1/2" and 2"**

GRATING PROFILES AVAILABLE...

R SERIES Light Duty Riveted Steel

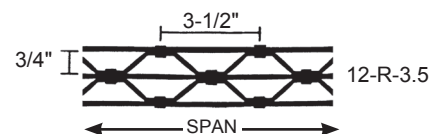
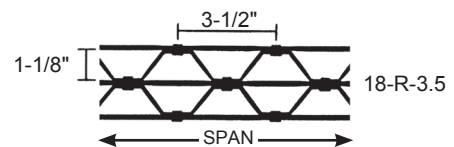
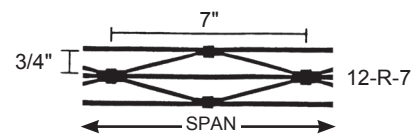
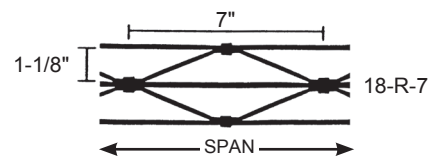

18-R-7 & 18-R-3-1/2

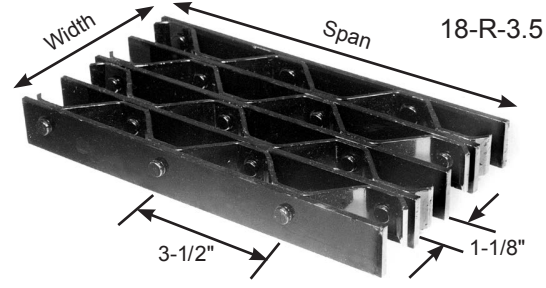
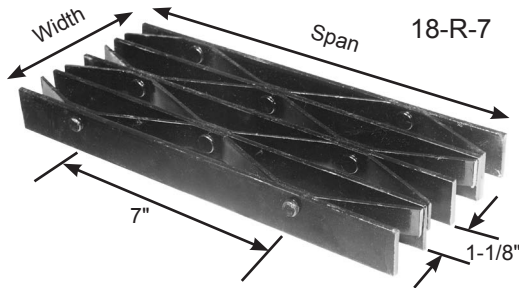

Bar Size, Inches	Ped Span, Inches	Wt. Lbs. Sq. Ft.	Sec. Prop Sx*, in ²	Ix*, in ⁴	Clear Span																		
					2'- 0"	2'- 6"	3'- 0"	3'- 6"	4'- 0"	4'- 6"	5'- 0"	5'- 6"	6'- 0"	6'- 6"	7'- 0"	8'- 0"							
3/4 x 3/16	48	7.80	0.204	U	613	392	272	200	153	121	U - Safe uniform load in pounds/sq. ft. C - Safe concentrated load in pounds/ft. grating width D - Deflection in inches Loads and deflections are theoretical and are based on a unit stress of 18,000 psi.												
				D	0.099	0.155	0.223	0.304	0.397	0.503													
			0.077	C	613	490	409	350	306	272													
				D	0.079	0.124	0.179	0.243	0.317	0.402													
1 x 1/8	53	7.60	0.242	U	726	465	323	237	182	143													
				D	0.074	0.116	0.168	0.228	0.299	0.376													
			0.121	C	726	581	484	415	363	323													
				D	0.060	0.093	0.134	0.182	0.238	0.302													
1 x 3/16	59	9.40	0.363	U	1089	697	484	356	272	215							174						
				D	0.074	0.116	0.168	0.228	0.298	0.377							0.465						
			0.182	C	1089	872	726	623	545	484							436						
				D	0.060	0.093	0.134	0.183	0.238	0.302							0.373						
1-1/4 x 1/8	63	8.70	0.378	U	1135	726	504	371	284	224	182	150											
				D	0.060	0.093	0.134	0.183	0.239	0.301	0.373	0.450											
			0.236	C	1135	908	757	648	567	504	454	413											
				D	0.048	0.074	0.107	0.146	0.191	0.241	0.298	0.361											
1-1/4 x 3/16	70	11.00	0.567	U	1702	1089	757	556	426	336	272	225	189										
				D	0.060	0.093	0.134	0.183	0.239	0.301	0.372	0.450	0.536										
			0.355	C	1702	1362	1135	973	851	757	681	619	567										
				D	0.048	0.074	0.107	0.146	0.191	0.241	0.298	0.360	0.429										
1-1/2 x 1/8	72	9.90	0.545	U	1634	1046	726	534	409	323	261	216	182	155									
				D	0.050	0.078	0.112	0.152	0.199	0.252	0.310	0.375	0.448	0.525									
			0.409	C	1634	1307	1089	934	817	726	654	594	545	503									
				D	0.040	0.062	0.089	0.122	0.159	0.201	0.248	0.300	0.358	0.420									
1-1/2 x 3/16	80	12.50	0.817	U	2451	1569	1089	800	613	484	392	324	272	232	200								
				D	0.050	0.078	0.112	0.152	0.199	0.251	0.310	0.375	0.446	0.524	0.608								
			0.613	C	2451	1961	1634	1401	1226	1089	981	891	817	754	700								
				D	0.040	0.062	0.089	0.122	0.159	0.201	0.248	0.300	0.357	0.419	0.486								
1-3/4 x 3/16	90	14.20	1.112	U	3336	2135	1483	1089	834	659	534	441	371	316	272	209							
				D	0.043	0.066	0.096	0.130	0.170	0.215	0.266	0.322	0.383	0.450	0.521	0.683							
			0.973	C	3336	2669	2224	1907	1668	1483	1335	1213	1112	1027	953	834							
				D	0.034	0.053	0.077	0.104	0.136	0.172	0.213	0.257	0.306	0.360	0.417	0.545							
2 x 3/16	99	16.80	1.453	U	4358	2789	1937	1423	1089	861	697	576	484	413	356	272							
				D	0.037	0.058	0.084	0.114	0.149	0.189	0.233	0.282	0.335	0.394	0.457	0.595							
			1.453	C	4358	3486	2905	2490	2179	1937	1743	1585	1453	1341	1245	1089							
				D	0.030	0.047	0.067	0.091	0.119	0.151	0.186	0.225	0.268	0.315	0.365	0.476							
2-1/4 x 3/16	108	18.30	1.838	U	5515	3530	2451	1801	1379	1089	882	729	613	522	450	345							
				D	0.033	0.052	0.074	0.101	0.132	0.168	0.207	0.250	0.298	0.350	0.405	0.530							
			2.068	C	5515	4412	3677	3152	2758	2451	2206	2006	1838	1697	1576	1379							
				D	0.026	0.041	0.060	0.081	0.106	0.134	0.166	0.200	0.238	0.280	0.324	0.424							
2-1/2 x 3/16	117	19.90	2.270	U	6809	4358	3026	2223	1702	1345	1089	900	757	645	556	426							
				D	0.030	0.047	0.067	0.091	0.119	0.151	0.186	0.225	0.268	0.315	0.365	0.477							
			2.837	C	6809	5447	4539	3891	3405	3026	2724	2476	2270	2095	1945	1702							
				D	0.024	0.037	0.054	0.073	0.095	0.121	0.149	0.180	0.215	0.252	0.292	0.381							

% Open Area*		
Bars	1/8"	3/16"
7" cc	78%	74%
3-1/2" cc	77%	73%

BB Size, Inches	CB Size, in. All Spacings
Thru 1-3/4	3/4 x 1/8
2 - 2-1/2	1 x 1/8

*Based on 11.621 bars/ft. of grating width. Bearing bars 1-1/8" face-to-face, connecting bars riveted 7" c.c. Add .4 lbs./sq. ft. for 18-R-3-1/2. Note: Grating for spans to the left of the heavy line have a deflection less than 1/4" for uniform loads of 100 lbs./sq. ft. This is the maximum deflection to afford pedestrian comfort and can be exceeded for other types of load at the discretion of the engineer. The actual Ped (pedestrian) Span under this condition is shown above for each size of grating.

Panel Width Chart (in.) - 18-R-7 & 18-R-3-1/2															
Dimensions Are Out-to-Out of Bearing Bars**															
No. of Bars	2	3	4	5	6	7	8	9	10	11	12	13	14	15	16
3/16" Bars	1-1/2	2-13/16	4-1/8	5-7/16	6-3/4	8-1/16	9-3/8	10-11/16	12	13-5/16	14-5/8	15-15/16	17-1/4	18-9/16	19-7/8
No. of Bars	17	18	19	20	21	22	23	24	25	26	27	28			
3/16" Bars	21-3/16	22-1/2	23-13/16	25-1/8	26-7/16	27-3/4	29-1/16	30-3/8	31-11/16	33	34-5/16	35-5/8			

**Add 1/4" for rivet heads. Deduct 1/16" for each 1/8" bearing bar. Standard panel widths indicated in blue.

12-R-7 & 12-R-3-1/2

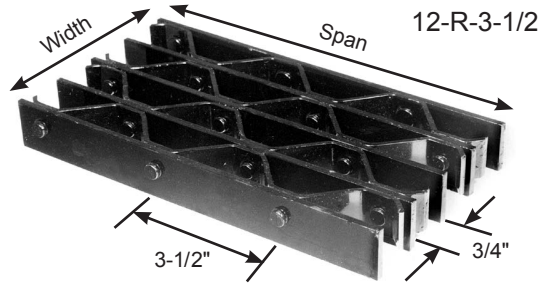
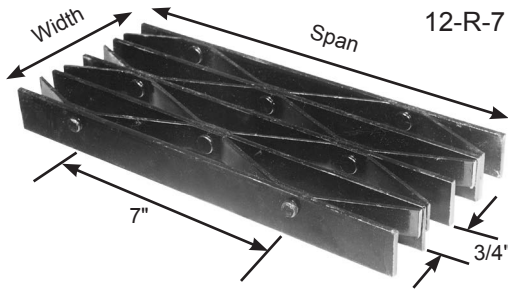

Bar Size, Inches	Ped Span, Inches	Wt. Lbs. Sq. Ft.	Sec. Prop Sx*, in ³ lx*, in ⁴	ClearSpan																								
				2'- 0"	2'- 6"	3'- 0"	3'- 6"	4'- 0"	4'- 6"	5'- 0"	5'- 6"	6'- 0"	6'- 6"	7'- 0"	8'- 0"													
3/4 x 3/16	52	10.70	0.286	U	858	549	381	280	214	169	U - Safe uniform load in pounds/ sq.ft. C - Safe concentrated load in pounds/ft. grating width D - Deflection in inches																	
				D	0.099	0.155	0.223	0.304	0.396	0.501																		
			0.107	C	858	686	572	490	429	381							0.079	0.124	0.179	0.243	0.318	0.402						
1 x 3/16	64	12.80	0.508	U	1525	976	678	498	381	301	244	202	<table border="1"> <thead> <tr> <th colspan="2">% Open Area</th> </tr> <tr> <th>Bars</th> <th>3/16"</th> </tr> </thead> <tbody> <tr> <td>7" cc</td> <td>65%</td> </tr> <tr> <td>3-1/2" cc</td> <td>64%</td> </tr> </tbody> </table> Loads and deflections are theoretical and are based on a unit stress of 18,000 psi.				% Open Area		Bars	3/16"	7" cc	65%	3-1/2" cc	64%				
				% Open Area																								
			Bars	3/16"																								
7" cc	65%																											
3-1/2" cc	64%																											
D	0.074	0.116	0.168	0.228	0.298	0.377	0.465	0.564																				
0.254	C	1525	1220	1017	872	763	678	610	555	0.060	0.093	0.134	0.183	0.238	0.302	0.372	0.451											
1-1/4 x 3/16	76	15.00	0.794	U	2383	1525	1059	778	596	471	381	315	265	226	<table border="1"> <thead> <tr> <th colspan="2">% Open Area</th> </tr> <tr> <th>Bars</th> <th>3/16"</th> </tr> </thead> <tbody> <tr> <td>7" cc</td> <td>65%</td> </tr> <tr> <td>3-1/2" cc</td> <td>64%</td> </tr> </tbody> </table> Loads and deflections are theoretical and are based on a unit stress of 18,000 psi.				% Open Area		Bars	3/16"	7" cc	65%	3-1/2" cc	64%		
				% Open Area																								
			Bars	3/16"																								
7" cc	65%																											
3-1/2" cc	64%																											
D	0.060	0.093	0.134	0.182	0.238	0.302	0.372	0.450	0.537	0.630																		
0.496	C	2383	1907	1589	1362	1192	1059	953	867	794	733	0.048	0.075	0.107	0.146	0.191	0.241	0.298	0.361	0.429	0.503							
1-1/2 x 3/16	87	17.10	1.144	U	3432	2196	1525	1121	858	678	549	454	381	325	280	214	<table border="1"> <thead> <tr> <th colspan="2">% Open Area</th> </tr> <tr> <th>Bars</th> <th>3/16"</th> </tr> </thead> <tbody> <tr> <td>7" cc</td> <td>65%</td> </tr> <tr> <td>3-1/2" cc</td> <td>64%</td> </tr> </tbody> </table> Loads and deflections are theoretical and are based on a unit stress of 18,000 psi.				% Open Area		Bars	3/16"	7" cc	65%	3-1/2" cc	64%
				% Open Area																								
			Bars	3/16"																								
7" cc	65%																											
3-1/2" cc	64%																											
D	0.050	0.078	0.112	0.152	0.199	0.251	0.310	0.376	0.447	0.525	0.608	0.793																
0.858	C	3432	2745	2288	1961	1716	1525	1373	1248	1144	1056	980	858	0.040	0.062	0.089	0.122	0.159	0.201	0.248	0.300	0.358	0.420	0.486	0.636			
1-3/4 x 3/16	98	19.40	1.557	U	4671	2989	2076	1525	1168	923	747	618	519	442	381	292	<table border="1"> <thead> <tr> <th colspan="2">% Open Area</th> </tr> <tr> <th>Bars</th> <th>3/16"</th> </tr> </thead> <tbody> <tr> <td>7" cc</td> <td>65%</td> </tr> <tr> <td>3-1/2" cc</td> <td>64%</td> </tr> </tbody> </table> Loads and deflections are theoretical and are based on a unit stress of 18,000 psi.				% Open Area		Bars	3/16"	7" cc	65%	3-1/2" cc	64%
				% Open Area																								
			Bars	3/16"																								
7" cc	65%																											
3-1/2" cc	64%																											
D	0.043	0.066	0.096	0.130	0.170	0.216	0.266	0.322	0.383	0.449	0.521	0.681																
1.362	C	4671	3737	3114	2669	2335	2076	1868	1699	1557	1437	1335	1168	0.034	0.053	0.077	0.104	0.136	0.172	0.213	0.258	0.306	0.360	0.417	0.545			
2 x 3/16	108	22.90	2.034	U	6101	3905	2712	1992	1525	1205	976	807	678	578	498	381	<table border="1"> <thead> <tr> <th colspan="2">% Open Area</th> </tr> <tr> <th>Bars</th> <th>3/16"</th> </tr> </thead> <tbody> <tr> <td>7" cc</td> <td>65%</td> </tr> <tr> <td>3-1/2" cc</td> <td>64%</td> </tr> </tbody> </table> Loads and deflections are theoretical and are based on a unit stress of 18,000 psi.				% Open Area		Bars	3/16"	7" cc	65%	3-1/2" cc	64%
				% Open Area																								
			Bars	3/16"																								
7" cc	65%																											
3-1/2" cc	64%																											
D	0.037	0.058	0.084	0.114	0.149	0.189	0.233	0.282	0.335	0.394	0.456	0.595																
2.034	C	6101	4881	4067	3486	3050	2712	2440	2219	2034	1877	1743	1525	0.030	0.047	0.067	0.091	0.119	0.151	0.186	0.225	0.268	0.315	0.365	0.477			
2-1/4 x 3/16	118	25.00	2.574	U	7721	4942	3432	2521	1930	1525	1235	1021	858	731	630	483	<table border="1"> <thead> <tr> <th colspan="2">% Open Area</th> </tr> <tr> <th>Bars</th> <th>3/16"</th> </tr> </thead> <tbody> <tr> <td>7" cc</td> <td>65%</td> </tr> <tr> <td>3-1/2" cc</td> <td>64%</td> </tr> </tbody> </table> Loads and deflections are theoretical and are based on a unit stress of 18,000 psi.				% Open Area		Bars	3/16"	7" cc	65%	3-1/2" cc	64%
				% Open Area																								
			Bars	3/16"																								
7" cc	65%																											
3-1/2" cc	64%																											
D	0.033	0.052	0.074	0.101	0.132	0.168	0.207	0.250	0.298	0.350	0.405	0.530																
2.896	C	7721	6177	5148	4412	3861	3432	3089	2808	2574	2376	2206	1930	0.026	0.041	0.060	0.081	0.106	0.134	0.166	0.200	0.238	0.280	0.324	0.424			
2-1/2 x 3/16	128	27.20	3.178	U	9533	6101	4237	3113	2383	1883	1525	1261	1059	902	778	596	<table border="1"> <thead> <tr> <th colspan="2">% Open Area</th> </tr> <tr> <th>Bars</th> <th>3/16"</th> </tr> </thead> <tbody> <tr> <td>7" cc</td> <td>65%</td> </tr> <tr> <td>3-1/2" cc</td> <td>64%</td> </tr> </tbody> </table> Loads and deflections are theoretical and are based on a unit stress of 18,000 psi.				% Open Area		Bars	3/16"	7" cc	65%	3-1/2" cc	64%
				% Open Area																								
			Bars	3/16"																								
7" cc	65%																											
3-1/2" cc	64%																											
D	0.030	0.047	0.067	0.091	0.119	0.151	0.186	0.225	0.268	0.315	0.365	0.477																
3.972	C	9533	7626	6355	5447	4766	4237	3813	3466	3178	2933	2724	2383	0.024	0.037	0.054	0.073	0.095	0.121	0.149	0.180	0.215	0.252	0.292	0.381			

*Based on 16.269 bars/ft. of grating width. Bearing bars 3/4" face-to-face, connecting bars riveted 7" c.c. Add .4 lbs./sq. ft. for 12-R-3-1/2. Note: Grating for spans to the left of the heavy line have a deflection less than 1/4" for uniform loads of 100 lbs./sq. ft. This is the maximum deflection to afford pedestrian comfort and can be exceeded for other types of load at the discretion of the engineer. The actual Ped (pedestrian) Span under this condition is shown above for each size of grating.

Panel Width Chart (in.) - 12-R-7 & 12-R-3-1/2 Dimensions Are Out-to-Out of Bearing Bars**

No. of Bars	2	3	4	5	6	7	8	9	10	11	12	13	14	15	16
3/16" Bars	1-1/8	2-1/16	3	3-15/16	4-7/8	5-13/16	6-3/4	7-11/16	8-5/8	9-9/16	10-1/2	11-7/16	12-3/8	13-5/16	14-1/4
No. of Bars	17	18	19	20	21	22	23	24	25	26	27	28	29	30	31
3/16" Bars	15-3/16	16-1/8	17-1/16	18	18-15/16	19-7/8	20-13/16	21-3/4	22-11/16	23-5/8	24-9/16	25-1/2	26-7/16	27-3/8	28-5/16
No. of Bars	32	33	34	35	36	37	38	39							
3/16" Bars	29-1/4	30-3/16	31-1/8	32-1/16	33	33-15/16	34-7/8	35-13/16							

**Add 1/4" for rivet heads. Deduct 1/16" for each 1/8" bearing bar. Standard panel widths indicated in blue.

LIGHT DUTY MBG PRESSLOCK



MBG PRESSLOCK

MBG PressLock is the perfect solution for mezzanine decking, pallet rack decking and shelving for the material handling market.

Within the manufacturing process, MBG PressLock grating offers flexibility to the end user based on the spacing and load requirements. Bar spacings are available in increments of $7/16$ " in either direction making it ideal for standard flooring applications as well as a multitude of architectural applications such as building facades, ADA walkways, fencing, sun screens, security barriers and handrail infill panels. The product is available in carbon steel and can be provided with various finishes including mill, galvanized and/or powder coated. OnGrip® Spray Traction Surface is also recommended for ADA Compliance.

GRATING PROFILES AVAILABLE... MBG PRESSLOCK Light Duty Steel

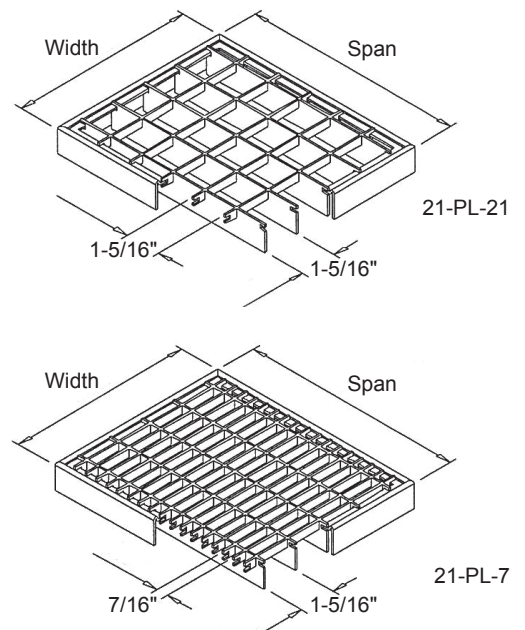

See load tables beginning on page 59.

LIGHT DUTY MBG PRESSLOCK

PRESSLOCK CONSTRUCTION

On our computer controlled production lines, the bearing bars are notched and then locked with the cross bar at very high pressure.

This particular production method guarantees a uniform precision mesh size.

The edge of MBG PressLock grating is banded either with a T-shaped special section or flat bar. This process (i.e. where the banding is welded at right angles to and flush with the grating surface) is done with automatic resistance welding.



SPECIAL ORDER

Optimal maximum panel width: 72"

Maximum panel span:

In practice the length will be predetermined by statistical requirements and unit weights.

End meshing:

Panel width and span edges must be equal dimensions.

MBG PressLock...the Smart Choice

The cross bar is inserted in the notches of the bearing bar and press locked into a stable structure at a force of 500 tons.

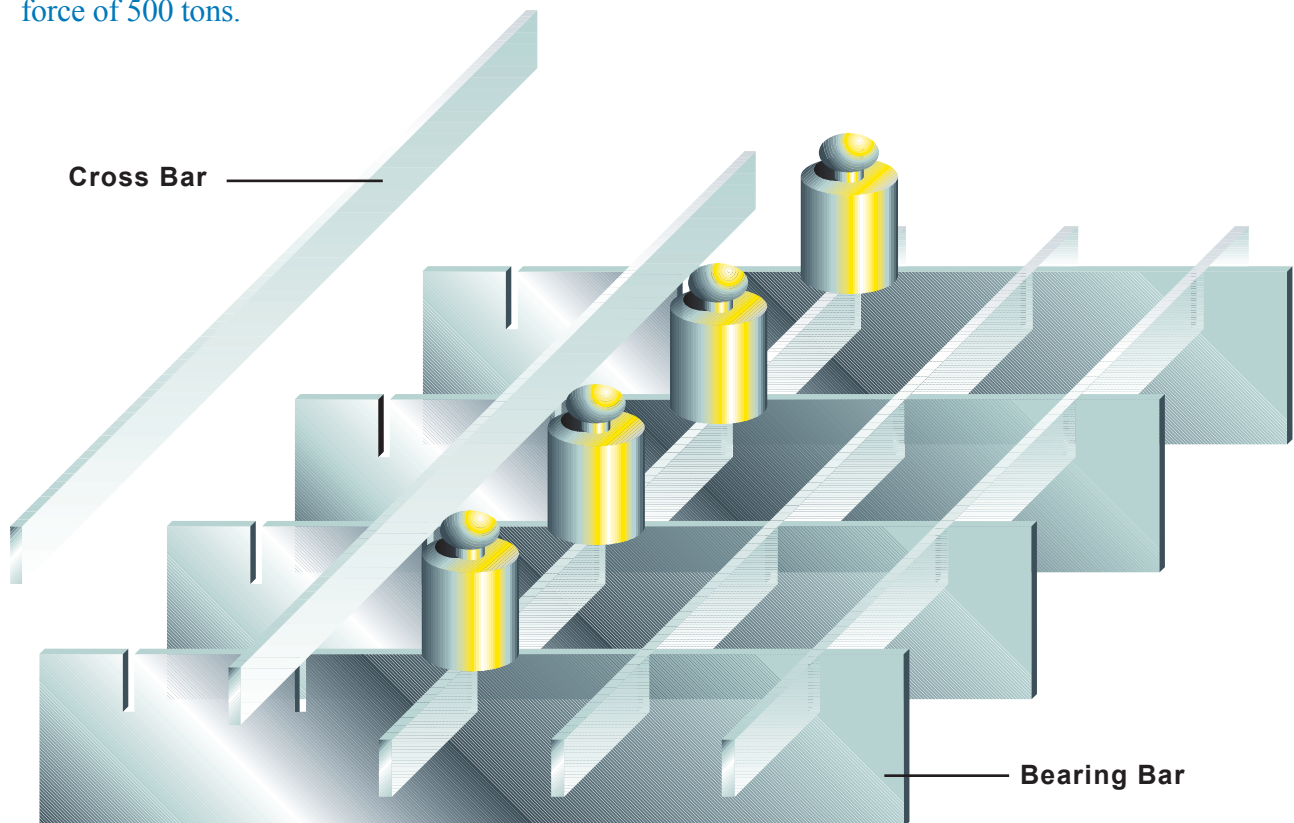

LIGHT DUTY MBG PRESSLOCK

TECHNICAL DATA

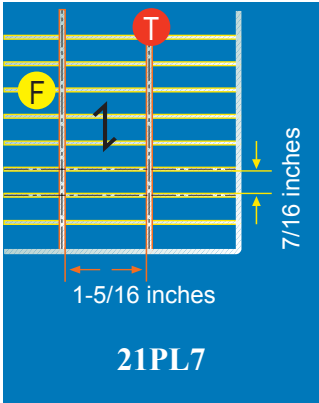

The Mesh Size on Press Lock Grating allows either bearing bars (T) or cross bars (F) to be spread in increments of 7/16". This provides a great deal of flexibility in design. The 21 PL7 is the designation for bearing bar spacing (21/16) and cross bar spacing (7/16).

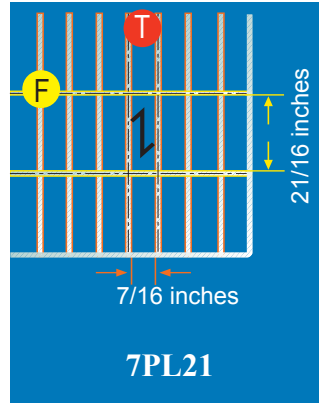

The 7PL21 is the designation for bearing bar spacing (7/16) and cross bar spacing (21/16).

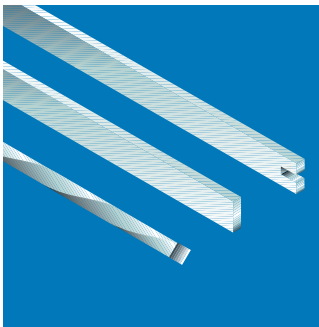

Cross Bars

At right angles to the bearing bars, the cross bars connect the bearing bars with one another in that they are pressed at the intersection points.

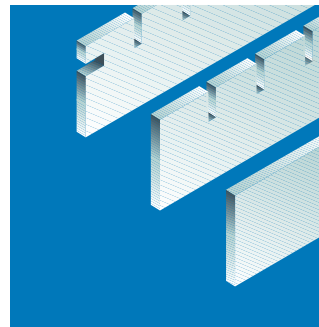

Bearing Bars

In parallel with one another, the bearing bars are the load carrying flat bars set out perpendicularly.

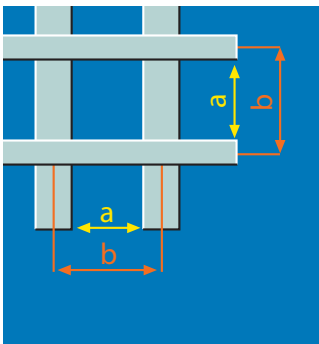

Mesh Spacing

Measurement from center to center (b) for the bearing bars and cross bars.

* Clear distance (a) between the bearing bar and the cross bar.

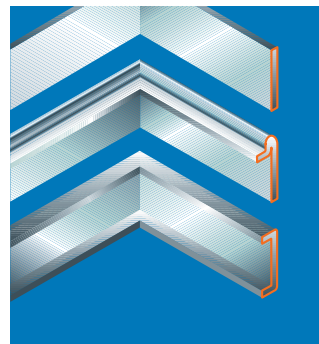

Banding Bars

Grating is usually banded all around by a flat bar, T-shaped section or U-shaped section.

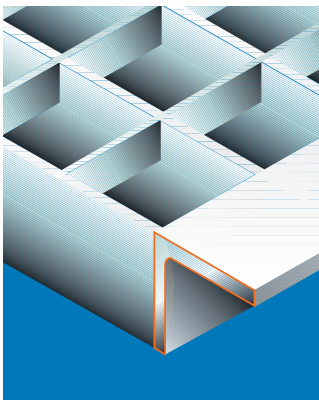

Angle Collar

Angles can be welded on to one or several edges. Angle height should be at least the same as the bearing bar.

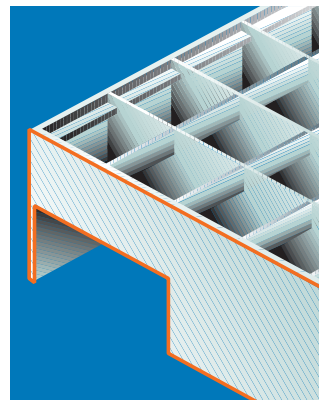

Notching

Special notching with extra-high banding in the shelving area.

LIGHT DUTY MBG PRESSLOCK

PROFILES

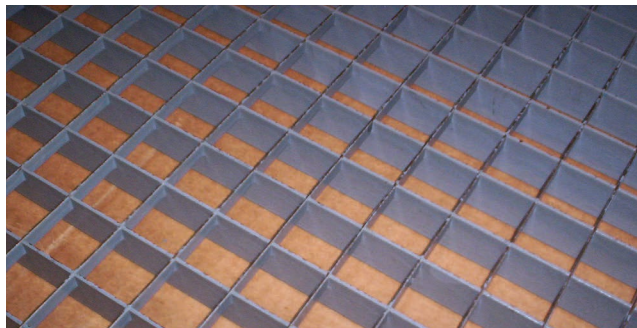

21PL21

Both the bearing bars and cross bars are spaced at 1-5/16" center to center. This spacing is appropriate when pushcarts & pallet jacks are not used on the mezzanines.

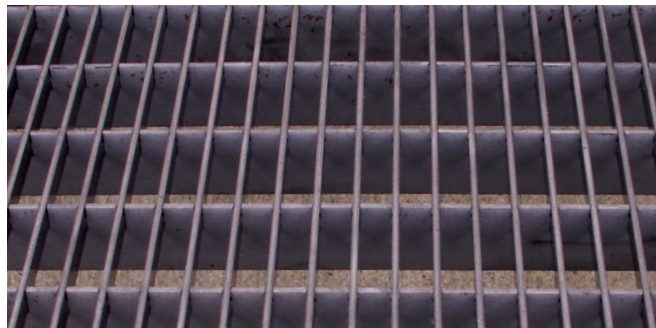

21PL7

This is the most popular spacing. (1-5/16" center to center on the bearing bars and 7/16" center to center on the cross bar). Ideal for carts & other rolling equipment.

FASTENERS

R Clips: A special formed metal fastener available in multiple sizes to fit any job.



R Clip on **21PL21** PressLock available in sizes: 1", 1-3/16", 1-1/4", 1-3/8", 1-1/2", 1-5/8", 1-3/4" and 2".

STORAGE RACK DECKING & SHELVING

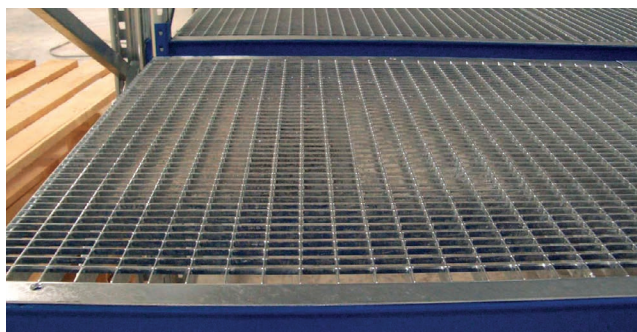

Decking

Manufactured from carbon steel with high load capacity for strength & stability to avoid deck failure like some wire deck products.



Shelving

PressLock Shelving has maximum shelf visibility for quick inventory checks and up to 84% open area allowing for air, light and maximum sprinkler performance in the event of a fire.

21-PL-21 & 21-PL-7

APPLICATIONS



This load chart is based on our medium size bar thickness (12 gauge), and includes bar heights from 1" through 3". Loads are calculated on 21PL spacing for the bearing bar or 1-5/16 center to center. Weight based on mill finish 21PL21 spacing; if 21PL7 add 2.32 pounds/square foot.

PEDESTRIAN LOAD TABLE

Bar Size, Inches	Ped Span, Inches	Wt. Lbs. Sq. Ft.	Sec. Prop Sx*, in ³ lx*, in ²	ClearSpan												
				2'- 0"	2'- 6"	3'- 0"	3'- 6"	4'- 0"	4'- 6"	5'- 0"	5'- 6"	6'- 0"	6'- 6"	7'- 0"	8'- 0"	
100M	40	4.31	0.1556	U	467	299	207	152	117	92	75	62	52	44	38	29
				D	0.074	0.1164	0.168	0.228	0.298	0.377	0.466	0.563	0.670	0.787	0.912	1.192
			0.0778	C	467	373	311	267	233	207	187	170	156	144	133	117
				D	0.060	0.093	0.134	0.182	0.238	0.302	0.372	0.451	0.536	0.629	0.730	0.953
118M	45	4.92	0.2167	U	650	416	289	212	162	128	104	86	72	62	53	41
				D	0.063	0.0986	0.142	0.193	0.252	0.320	0.395	0.477	0.568	0.667	0.773	1.010
			0.1278	C	650	520	433	371	325	289	260	236	217	200	186	162
				D	0.050	0.079	0.114	0.155	0.202	0.256	0.316	0.382	0.454	0.533	0.619	0.808
125M	47	5.16	0.2431	U	729	467	324	238	182	144	117	96	81	69	60	46
				D	0.060	0.0931	0.134	0.182	0.238	0.302	0.372	0.451	0.536	0.629	0.730	0.953
			0.1520	C	729	584	486	417	365	324	292	265	243	224	208	182
				D	0.048	0.074	0.107	0.146	0.191	0.241	0.298	0.360	0.429	0.504	0.584	0.763
138M	51	5.61	0.2963	U	889	569	395	290	222	176	142	118	99	84	73	56
				D	0.054	0.0843	0.121	0.165	0.216	0.273	0.337	0.408	0.486	0.570	0.661	0.864
			0.2045	C	889	711	593	508	444	395	356	323	296	274	254	222
				D	0.043	0.067	0.097	0.132	0.173	0.219	0.270	0.327	0.389	0.456	0.529	0.691
150M	54	6.02	0.3501	U	1050	672	467	343	263	207	168	139	117	99	86	66
				D	0.050	0.0776	0.112	0.152	0.199	0.251	0.310	0.376	0.447	0.524	0.608	0.794
			0.2626	C	1050	840	700	600	525	467	420	382	350	323	300	263
				D	0.040	0.062	0.089	0.122	0.159	0.201	0.248	0.300	0.358	0.420	0.487	0.636
158M	56	6.29	0.3884	U	1165	746	518	381	291	230	186	154	129	110	95	73
				D	0.047	0.0737	0.106	0.144	0.189	0.239	0.295	0.357	0.424	0.498	0.577	0.754
			0.3069	C	1165	932	777	666	583	518	466	424	388	359	333	291
				D	0.038	0.059	0.085	0.115	0.151	0.191	0.236	0.286	0.339	0.098	0.462	0.603
175M	61	6.88	0.4765	U	1430	915	635	467	357	282	229	189	159	135	117	89
				D	0.043	0.0665	0.096	0.130	0.170	0.215	0.266	0.322	0.383	0.450	0.521	0.681
			0.4170	C	1430	1144	953	817	715	635	572	520	477	440	408	357
				D	0.034	0.053	0.077	0.104	0.136	0.172	0.213	0.257	0.306	0.360	0.417	0.545
200M	67	7.73	0.6224	U	1867	1195	830	610	487	369	299	247	207	177	152	117
				D	0.037	0.0582	0.084	0.114	0.149	0.189	0.233	0.282	0.335	0.393	0.456	0.596
			0.6224	C	1867	1494	1245	1067	934	830	747	679	622	575	533	467
				D	0.030	0.047	0.067	0.091	0.119	0.151	0.186	0.225	0.268	0.315	0.365	0.477

*Calculations based on a uniform load of 100 pounds/square foot with maximum 1/8" deflection; figured per NAAMM standards

**For Galvanized add 7.5% to weight per square foot. 100M through 200M represents bearing bar height and thickness. Example: 100 = 1" high bar; 125 = 1-1/4"

***M (Medium) identifies bearing bar thickness of 12 gauge (.1046 in/2.66mm)

21-PL-21 & 21-PL-7

PROBLEM



1" x 1/8" 19W4 weld forge

SOLUTION

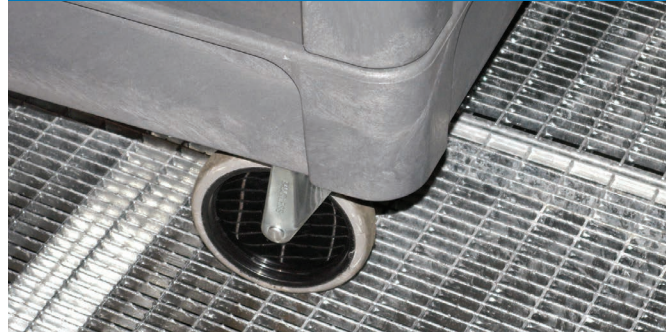

21PL7 - PressLock

This load chart is based on our standard size bar thickness (14 gauge), and includes bar heights from 1" through 2". Loads are calculated on 21PL spacing for the bearing bars or 1-5/16" center to center. Weight based on mill finish 21PL21 spacing; if 21PL7, add 1.93 pounds per square foot.

PEDESTRIAN LOAD TABLE

Bar Size, Inches	Ped Span, Inches	Wt. Lbs. Sq. Ft.	Sec. Prop Sx ² , in ² lx ² , in ⁴	ClearSpan												
				2'- 0"	2'- 6"	3'- 0"	3'- 6"	4'- 0"	4'- 6"	5'- 0"	5'- 6"	6'- 0"	6'- 6"	7'- 0"	8'- 0"	
100S	36	3.42	0.1098	U	330	211	146	108	82	65	53	44	37	31	27	21
				D	0.074	0.1164	0.168	0.228	0.298	0.377	0.466	0.563	0.670	0.787	0.912	1.192
			0.0549	C	330	264	220	188	165	146	132	120	110	101	94	82
				D	0.060	0.093	0.134	0.182	0.238	0.302	0.372	0.451	0.536	0.629	0.730	0.953
118S	41	3.87	0.1529	U	459	294	204	150	115	91	73	61	51	43	37	29
				D	0.063	0.0986	0.142	0.193	0.252	0.320	0.395	0.477	0.568	0.667	0.773	1.010
			0.0902	C	459	367	306	262	229	204	184	167	153	141	131	115
				D	0.050	0.079	0.114	0.155	0.202	0.256	0.316	0.382	0.454	0.533	0.619	0.808
125S	43	4.05	0.1716	U	515	330	229	168	129	102	82	68	57	49	42	32
				D	0.060	0.0931	0.134	0.182	0.238	0.302	0.372	0.451	0.536	0.629	0.730	0.953
			0.1073	C	515	412	343	294	257	229	206	187	172	158	147	129
				D	0.048	0.074	0.107	0.146	0.191	0.241	0.298	0.360	0.429	0.504	0.584	0.763
138S	46	4.38	0.2092	U	628	402	279	205	157	124	100	83	70	59	51	39
				D	0.054	0.0843	0.121	0.165	0.216	0.273	0.337	0.408	0.486	0.570	0.661	0.864
			0.1443	C	628	502	418	359	314	279	251	228	209	193	179	157
				D	0.043	0.067	0.097	0.132	0.173	0.219	0.270	0.327	0.389	0.456	0.529	0.691
150S	49	4.68	0.2471	U	741	474	330	242	185	146	119	98	82	70	61	46
				D	0.050	0.0776	0.112	0.152	0.199	0.251	0.310	0.376	0.447	0.524	0.608	0.794
			0.1854	C	741	593	494	424	371	330	297	270	247	228	212	185
				D	0.040	0.062	0.089	0.122	0.159	0.201	0.248	0.300	0.358	0.420	0.487	1.636
158S	51	4.89	0.2742	U	823	526	366	269	206	162	132	109	91	78	67	51
				D	0.047	0.0737	0.106	0.144	0.189	0.239	0.295	0.357	0.424	0.498	0.577	0.754
			0.2166	C	823	658	548	470	411	366	329	299	274	253	235	206
				D	0.038	0.059	0.085	0.115	0.151	0.191	0.236	0.285	0.339	0.398	0.462	0.603
175S	55	5.32	0.3364	U	1009	646	449	330	252	199	161	133	112	96	82	63
				D	0.043	0.0665	0.096	0.130	0.170	0.215	0.266	0.322	0.383	0.450	0.521	0.681
			0.2943	C	1009	807	673	577	505	449	404	367	336	311	288	252
				D	0.034	0.053	0.077	0.104	0.136	0.172	0.213	0.257	0.306	0.360	0.417	0.545
200S	61	5.95	0.4394	U	1318	844	586	430	330	260	211	174	146	125	108	82
				D	0.037	0.0582	0.084	0.114	0.149	0.189	0.233	0.282	0.335	0.393	0.456	0.596
			0.4394	C	1318	1054	879	753	659	586	527	479	439	406	377	330
				D	0.030	0.047	0.067	0.091	0.119	0.151	0.186	0.225	0.268	0.315	0.365	0.477

*Calculations based on a uniform load of 100 pounds/square foot with maximum 1/8" deflection; figured per NAAMM standards

**For Galvanized add 7.5% to weight per square foot. 100S through 200S represents bearing bar height and thickness. Example: 100 = 1" high bar; 125 = 1-1/4"

***S (Standard) identifies bearing bar thickness of 14 gauge (.0747 in/1.905mm)

SWAGED STAINLESS STEEL



SGSS SERIES



The swaging process allows the assembly of bar grating panels by mechanically locking the cross bars at right angles to the bearing bars at a maximum of 4" on center. This process provides the clean crisp lines of a recessed cross bar and eliminates the discoloration inherent with welded bar grating. By using the most modern technology available, swaged bar grating allows for a variety of spacings including close spacings of 7/16" cc between bearing bars which have been approved by the "Americans with Disabilities Act".

Stainless steel grating has been the standard industrial footwalk product for severe corrosive environments and has been a popular grating choice for many years. Ohio Gratings manufactures stainless swaged bar grating from type 304 and 316 stainless steel bar. Stainless steel grating is used at chemical plants, food processing facilities, oil and gas producers and is also used in many other commercial and architectural applications.

OnGrip® Spray Traction Surface is also available.

GRATING PROFILES AVAILABLE... SGSS SERIES Swaged Stainless Steel

All profiles shown below are also available with 2" cross bar centers. Product numbers would be 19-SGSS-2, 15-SGSS-2, 11-SGSS-2 and 7-SGSS-2

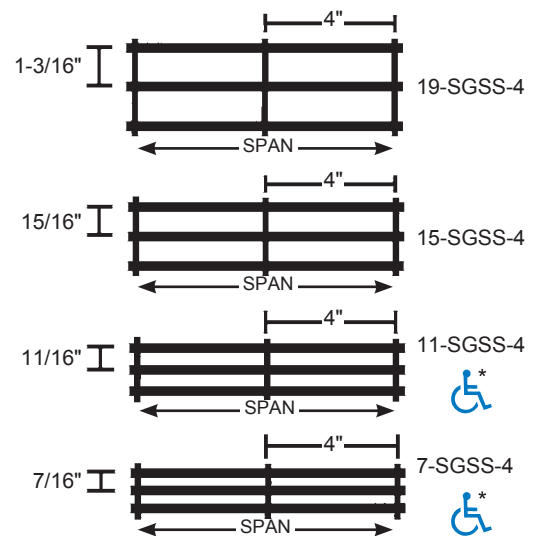

***Note:** Conforms with the spacing requirements of ADA (September 2010) when installed with the elongated opening perpendicular to the dominant direction of travel. See ADA Guidelines

19 SPACE

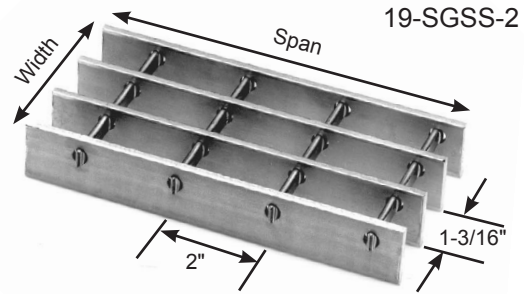
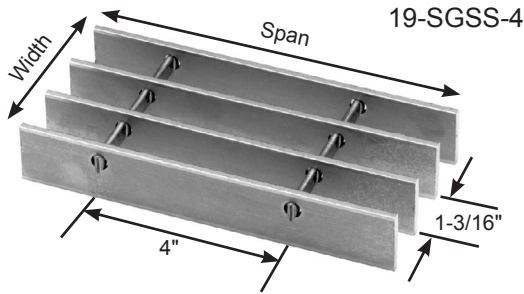

Bar Size, Inches	Ped Span, Inches	Wt.* Lbs. Sq. Ft.	Sec. Prop Sx*, in² lx*, in⁴	ClearSpan																		
				2'- 0"	2'- 6"	3'- 0"	3'- 6"	4'- 0"	4'- 6"	5'- 0"	5'- 6"	6'- 0"	6'- 6"	7'- 0"	8'- 0"							
3/4 x 3/16	46	5.64	0.178	U	592	379	263	193	148							U - Safe uniform load in pounds /sq.ft. C - Safe concentrated load in pounds /ft. grating width D - Deflection in inches						
				D	0.114	0.179	0.257	0.349	0.457													
			0.067	C	592	474	395	338	296							Loads and deflections are theoretical and based on a unit stress of 20,000 psi.						
				D	0.091	0.143	0.206	0.280	0.366													
1 x 1/8	51	4.99	0.211	U	702	449	312	229	175	139												
				D	0.086	0.134	0.193	0.262	0.342	0.435												
			0.105	C	702	561	468	401	351	312												
				D	0.069	0.107	0.154	0.210	0.274	0.347												
1 x 3/16	56	7.19	0.316	U	1053	674	468	344	263	208	168											
				D	0.086	0.134	0.193	0.263	0.343	0.434	0.534											
			0.158	C	1053	842	702	601	526	468	421											
				D	0.069	0.107	0.154	0.210	0.274	0.347	0.429											
1-1/4 x 1/8	60	6.09	0.329	U	1096	702	487	358	274	217	175	145										
				D	0.069	0.107	0.154	0.210	0.274	0.348	0.428	0.519										
			0.206	C	1096	877	731	627	548	487	439	399										
				D	0.055	0.086	0.123	0.168	0.219	0.278	0.343	0.415										
1-1/4 x 3/16	67	8.84	0.493	U	1645	1053	731	537	411	325	263	217	183									
				D	0.069	0.107	0.154	0.210	0.274	0.347	0.428	0.517	0.618									
			0.308	C	1645	1316	1096	940	822	731	658	598	548									
				D	0.055	0.086	0.123	0.168	0.219	0.278	0.343	0.415	0.494									
1-1/2 x 1/8	69	7.19	0.474	U	1579	1011	702	516	395	312	253	209	175									
				D	0.057	0.089	0.129	0.175	0.229	0.289	0.358	0.433	0.513									
			0.355	C	1579	1263	1053	902	789	702	632	574	526									
				D	0.046	0.071	0.103	0.140	0.183	0.232	0.286	0.346	0.411									
1-1/2 x 3/16	77	10.48	0.711	U	2368	1516	1053	773	592	468	379	313	263	224								
				D	0.057	0.089	0.129	0.175	0.229	0.289	0.357	0.432	0.514	0.603								
			0.533	C	2368	1895	1579	1353	1184	1053	947	861	789	729								
				D	0.046	0.071	0.103	0.140	0.183	0.232	0.286	0.346	0.411	0.483								
1-3/4 x 3/16	86	11.71	0.967	U	3224	2063	1433	1053	806	637	516	426	358	305	263	201						
				D	0.049	0.077	0.110	0.150	0.196	0.248	0.306	0.370	0.441	0.517	0.600	0.782						
			0.846	C	3224	2579	2149	1842	1612	1433	1289	1172	1075	992	921	806						
				D	0.039	0.061	0.088	0.120	0.157	0.198	0.245	0.296	0.353	0.414	0.480	0.627						
2 x 3/16	95	13.78	1.263	U	4210	2695	1871	1375	1053	832	674	557	468	399	344	263						
				D	0.043	0.067	0.096	0.131	0.171	0.217	0.268	0.324	0.386	0.453	0.525	0.685						
			1.263	C	4210	3368	2807	2406	2105	1871	1684	1531	1403	1296	1203	1053						
				D	0.034	0.054	0.077	0.105	0.137	0.174	0.214	0.259	0.308	0.362	0.420	0.549						
2-1/4 x 3/16	104	15.49	1.599	U	5329	3410	2368	1740	1332	1053	853	705	592	505	435	333						
				D	0.038	0.060	0.086	0.117	0.152	0.193	0.238	0.288	0.343	0.403	0.467	0.609						
			1.798	C	5329	4263	3553	3045	2664	2368	2132	1938	1776	1640	1523	1332						
				D	0.030	0.048	0.069	0.093	0.122	0.154	0.191	0.231	0.274	0.322	0.373	0.488						
2-1/2 x 3/16	112	17.08	1.974	U	6579	4210	2924	2148	1645	1300	1053	870	731	623	537	411						
				D	0.034	0.054	0.077	0.105	0.137	0.174	0.214	0.259	0.309	0.362	0.420	0.548						
			2.467	C	6579	5263	4386	3759	3289	2924	2632	2392	2193	2024	1880	1645						
				D	0.027	0.043	0.062	0.084	0.110	0.139	0.171	0.207	0.247	0.290	0.336	0.439						

% Open Area*		
Bars	1/8"	3/16"
4" cc	83%	78%
2" cc	76%	72%

*Based on 10,105 bars/ft. of grating width. Bearing bars 1-3/16" c.c. Add 6 lbs./sq. ft. for 19-SGSS-2. Note: Grating for spans to the left of the heavy line have a deflection less than 1/4" for uniform loads of 100 lbs./sq. ft. This is the maximum deflection to afford pedestrian comfort and can be exceeded for other types of load at the discretion of the engineer. The actual Ped (pedestrian) Span under this condition is shown above for each size of grating. When serrated grating is specified, the depth of grating required for a specific load will be 1/4" greater than that shown in these tables. 3/4" x 3/16" serrated grating is not available.

Panel Width Chart (in.) - 19-SGSS-4 & 19-SGSS-2 Dimensions Are Out-to-Out of Bearing Bars**

No. of Bars	2	3	4	5	6	7	8	9	10	11	12	13	14	15	16
3/16" Bars	1-3/8	2-9/16	3-3/4	4-15/16	6-1/8	7-5/16	8-1/2	9-11/16	10-7/8	12-1/16	13-1/4	14-7/16	15-5/8	16-13/16	18
No. of Bars	17	18	19	20	21	22	23	24	25	26	27	28	29	30	31
3/16" Bars	19-3/16	20-3/8	21-9/16	22-3/4	23-15/16	25-1/8	26-5/16	27-1/2	28-11/16	29-7/8	31-1/16	32-1/4	33-7/16	34-5/8	35-13/16

**Add 1/4" for extended cross bars. Deduct 1/16" for 1/8" bearing bars. Standard panel widths indicated in red.

15 SPACE

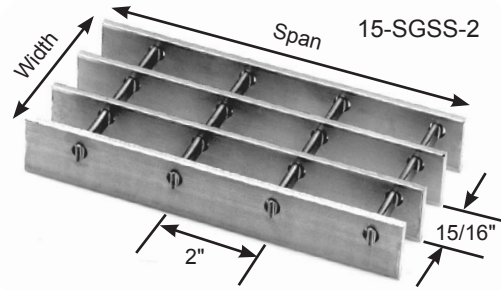
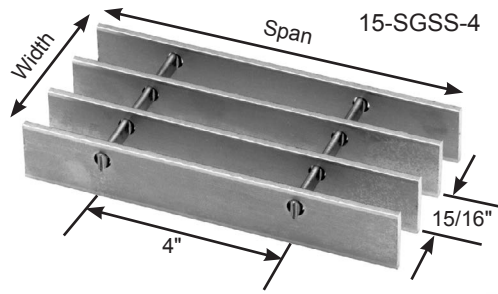

Bar Size, Inches	Ped Span, Inches	Wt.* Lbs. Sq. Ft.	Sec. Prop Sx*, in ³ Ix*, in ⁴	ClearSpan																							
				2'- 0"	2'- 6"	3'- 0"	3'- 6"	4'- 0"	4'- 6"	5'- 0"	5'- 6"	6'- 0"	6'- 6"	7'- 0"	8'- 0"												
3/4 x 3/16	48	6.99	0.225	U	750	480	333	245	188	148	U - Safe uniform load in pounds /sq.ft. C - Safe concentrated load in pounds /ft. grating width D - Deflection in inches																
				D	0.114	0.179	0.257	0.350	0.458	0.578																	
			0.084	C	750	600	500	429	375	333																	
				D	0.091	0.143	0.206	0.280	0.366	0.462																	
1 x 3/16	60	8.95	0.400	U	1333	853	593	435	333	263	213	176	Loads and deflections are theoretical and based on a unit stress of 20,000 psi.														
				D	0.086	0.134	0.193	0.262	0.343	0.433	0.535	0.647															
			0.200	C	1333	1067	889	762	667	593	533	485															
				D	0.069	0.107	0.154	0.210	0.274	0.347	0.428	0.519															
1-1/4 x 3/16	71	11.03	0.625	U	2083	1333	926	680	521	412	333	275	231	<table border="1"> <thead> <tr> <th colspan="3">% Open Area*</th> </tr> <tr> <th>Bars</th> <th>1/8"</th> <th>3/16"</th> </tr> </thead> <tbody> <tr> <td>4" cc</td> <td>N/A</td> <td>74%</td> </tr> <tr> <td>2" cc</td> <td>N/A</td> <td>68%</td> </tr> </tbody> </table>		% Open Area*			Bars	1/8"	3/16"	4" cc	N/A	74%	2" cc	N/A	68%
				% Open Area*																							
			Bars	1/8"	3/16"																						
			4" cc	N/A	74%																						
2" cc	N/A	68%																									
D	0.069	0.107	0.154	0.210	0.274	0.348	0.428	0.518	0.616																		
0.391	C	2083	1667	1389	1190	1042	926	833	758	694																	
	D	0.055	0.086	0.123	0.168	0.219	0.278	0.343	0.415	0.493																	
1-1/2 x 3/16	81	13.12	0.900	U	3000	1920	1333	980	750	593	480	397	333	284	245												
				D	0.057	0.089	0.129	0.175	0.229	0.289	0.357	0.432	0.514	0.604	0.700												
			0.675	C	3000	2400	2000	1714	1500	1333	1200	1091	1000	923	857												
				D	0.046	0.071	0.103	0.140	0.183	0.231	0.286	0.346	0.411	0.483	0.560												
1-3/4 x 3/16	91	14.67	1.225	U	4083	2613	1815	1333	1021	807	653	540	454	387	333	255											
				D	0.049	0.077	0.110	0.150	0.196	0.248	0.306	0.370	0.441	0.518	0.599	0.783											
			1.072	C	4083	3267	2722	2333	2042	1815	1633	1485	1361	1256	1167	1021											
				D	0.039	0.061	0.088	0.120	0.157	0.198	0.245	0.296	0.353	0.414	0.480	0.627											
2 x 3/16	101	17.29	1.600	U	5333	3413	2370	1741	1333	1053	853	705	593	505	435	333											
				D	0.043	0.067	0.096	0.131	0.171	0.217	0.268	0.324	0.386	0.453	0.525	0.685											
			1.600	C	5333	4267	3556	3048	2667	2370	2133	1939	1778	1641	1524	1333											
				D	0.034	0.054	0.077	0.105	0.137	0.174	0.214	0.259	0.309	0.362	0.420	0.548											
2-1/4 x 3/16	110	19.47	2.025	U	6750	4320	3000	2204	1688	1333	1080	893	750	639	551	422											
				D	0.038	0.060	0.086	0.117	0.152	0.193	0.238	0.288	0.343	0.402	0.467	0.610											
			2.278	C	6750	5400	4500	3857	3375	3000	2700	2455	2250	2077	1929	1688											
				D	0.030	0.048	0.069	0.093	0.122	0.154	0.190	0.231	0.274	0.322	0.373	0.488											
2-1/2 x 3/16	119	21.48	2.500	U	8333	5333	3704	2721	2083	1646	1333	1102	926	789	680	521											
				D	0.034	0.054	0.077	0.105	0.137	0.174	0.214	0.259	0.309	0.362	0.420	0.549											
			3.125	C	8333	6667	5556	4762	4167	3704	3333	3030	2778	2564	2381	2083											
				D	0.027	0.043	0.062	0.084	0.110	0.139	0.171	0.207	0.247	0.290	0.336	0.439											

*Based on 12.8 bars/ft. of grating width. Bearing bars 15/16" c.c. Add .6 lbs./sq. ft. for 15-SGSS-2. 1/8" bearing bars available by inquiry. **Note:** Grating for spans to the left of the heavy line have a deflection less than 1/4" for uniform loads of 100 lbs./sq. ft. This is the maximum deflection to afford pedestrian comfort and can be exceeded for other types of load at the discretion of the engineer. The actual Ped (pedestrian) Span under this condition is shown above for each size of grating. When serrated grating is specified, the depth of grating required for a specific load will be 1/4" greater than that shown in these tables. 3/4" x 3/16" serrated grating is not available.

Panel Width Chart (in.) - 15-SGSS-4 & 15-SGSS-2															
Dimensions Are Out-to-Out of Bearing Bars**															
No. of Bars	2	3	4	5	6	7	8	9	10	11	12	13	14	15	16
3/16" Bars	1-1/8	2-1/16	3	3-15/16	4-7/8	5-13/16	6-3/4	7-11/16	8-5/8	9-9/16	10-1/2	11-7/16	12-3/8	13-5/16	14-1/4
No. of Bars	17	18	19	20	21	22	23	24	25	26	27	28	29	30	31
3/16" Bars	15-3/16	16-1/8	17-1/16	18	18-15/16	19-7/8	20-13/16	21-3/4	22-11/16	23-5/8	24-9/16	25-1/2	26-7/16	27-3/8	28-5/16
No. of Bars	32	33	34	35	36	37	38	39							
3/16" Bars	29-1/4	30-3/16	31-1/8	32-1/16	33	33-15/16	34-7/8	35-13/16							

**Add 1/4" for extended cross bars. Deduct 1/16" for 1/8" bearing bars. Standard panel widths indicated in red.

11 SPACE

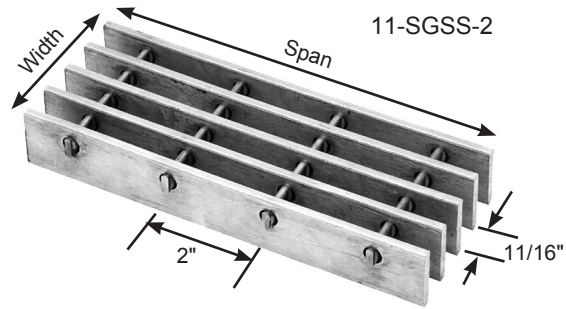
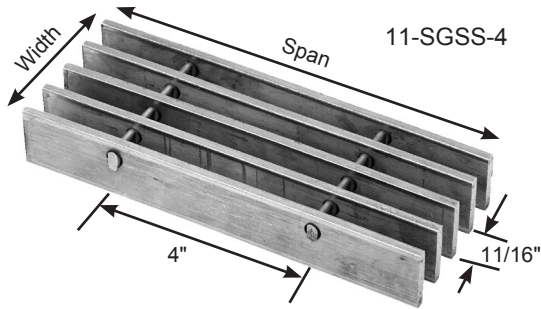

Bar Size, Inches	Ped Span, Inches	Wt.* Lbs. Sq. Ft.	Sec. Prop Sx*, in ² lx*, in ⁴	ClearSpan																														
				2'- 0"	2'- 6"	3'- 0"	3'- 6"	4'- 0"	4'- 6"	5'- 0"	5'- 6"	6'- 0"	6'- 6"	7'- 0"	8'- 0"																			
3/4 x 3/16	52	9.32	0.307	U	1023	655	455	334	256	202	U - Safe uniform load in pounds/ sq.ft. C - Safe concentrated load in pounds/ ft. grating width D - Deflection in inches																							
				D	0.114	0.179	0.257	0.350	0.458	0.578																								
			0.115	C	1023	818	682	584	511	455																								
				D	0.091	0.143	0.206	0.280	0.365	0.463																								
1 x 3/16	65	11.99	0.545	U	1818	1164	808	594	455	359							291	240	<table border="1"> <thead> <tr> <th colspan="3">% Open Area*</th> </tr> <tr> <th>Bars</th> <th>1/8"</th> <th>3/16"</th> </tr> </thead> <tbody> <tr> <td>4" cc</td> <td>N/A</td> <td>67%</td> </tr> <tr> <td>2" cc</td> <td>N/A</td> <td>62%</td> </tr> </tbody> </table>				% Open Area*			Bars	1/8"	3/16"	4" cc	N/A	67%	2" cc	N/A	62%
				% Open Area*																														
			Bars	1/8"	3/16"																													
			4" cc	N/A	67%																													
2" cc	N/A	62%																																
D	0.086	0.134	0.193	0.263	0.343	0.434	0.536	0.647																										
0.273	C	1818	1455	1212	1039	909	808	727	661																									
	D	0.069	0.107	0.154	0.210	0.274	0.347	0.428	0.518																									
1-1/4 x 3/16	77	14.83	0.852	U	2841	1818	1263	928	710	561	455	376	316	269	Loads and deflections are theoretical and are based on a unit stress of 20,000 psi.																			
				D	0.069	0.107	0.154	0.210	0.274	0.347	0.429	0.519	0.618	0.724																				
			0.533	C	2841	2273	1894	1623	1420	1263	1136	1033	947	874																				
				D	0.055	0.086	0.123	0.168	0.219	0.278	0.343	0.415	0.494	0.579																				
1-1/2 x 3/16	88	17.68	1.227	U	4091	2618	1818	1336	1023	808	655	541	455	387			334	256																
				D	0.057	0.089	0.129	0.175	0.229	0.289	0.357	0.432	0.515	0.603			0.700	0.915																
			0.920	C	4091	3273	2727	2338	2046	1818	1636	1488	1364	1259			1169	1023																
				D	0.046	0.071	0.103	0.140	0.183	0.231	0.286	0.346	0.412	0.483			0.560	0.732																
1-3/4 x 3/16	99	19.79	1.670	U	5568	3564	2475	1818	1392	1100	891	736	619	527			455	348																
				D	0.049	0.077	0.110	0.150	0.196	0.248	0.306	0.370	0.441	0.517			0.601	0.784																
			1.462	C	5568	4455	3712	3182	2784	2475	2227	2025	1856	1713			1591	1392																
				D	0.039	0.061	0.088	0.120	0.157	0.198	0.245	0.296	0.353	0.414			0.480	0.627																
2 x 3/16	109	23.37	2.182	U	7273	4655	3232	2375	1818	1437	1164	962	808	689	594	455																		
				D	0.043	0.067	0.096	0.131	0.171	0.217	0.268	0.324	0.386	0.453	0.525	0.686																		
			2.182	C	7273	5818	4849	4156	3636	3232	2909	2645	2424	2238	2078	1818																		
				D	0.034	0.054	0.077	0.105	0.137	0.174	0.214	0.259	0.309	0.362	0.420	0.549																		
2-1/4 x 3/16	119	26.34	2.761	U	9205	5891	4091	3006	2301	1818	1473	1217	1023	871	751	575																		
				D	0.038	0.060	0.086	0.117	0.152	0.193	0.238	0.288	0.343	0.402	0.466	0.609																		
			3.107	C	9205	7364	6137	5260	4602	4091	3682	3347	3068	2832	2630	2301																		
				D	0.030	0.048	0.069	0.093	0.122	0.154	0.190	0.230	0.274	0.322	0.373	0.488																		
2-1/2 x 3/16	129	29.08	3.409	U	11364	7273	5051	3711	2841	2245	1818	1503	1263	1076	928	710																		
				D	0.034	0.054	0.077	0.105	0.137	0.174	0.214	0.259	0.309	0.362	0.420	0.548																		
			4.261	C	11364	9091	7576	6494	5682	5051	4546	4132	3788	3497	3247	2841																		
				D	0.027	0.043	0.062	0.084	0.110	0.139	0.171	0.207	0.247	0.290	0.336	0.439																		

*Based on 17.455 bars/ft. of grating width. Bearing bars 11/16" c.c. Add .6 lbs./sq. ft. for 11-SGSS-2. 1/8" bearing bars available by inquiry. **Note:** Grating for spans to the left of the heavy line have a deflection less than 1/4" for uniform loads of 100 lbs./sq. ft. This is the maximum deflection to afford pedestrian comfort and can be exceeded for other types of load at the discretion of the engineer. The actual Ped (pedestrian) Span under this condition is shown above for each size of grating. When serrated grating is specified, the depth of grating required for a specific load will be 1/4" greater than that shown in these tables. 3/4" x 3/16" serrated grating is not available.

Panel Width Chart (in.) - 11-SGSS-4 & 11-SGSS-2 Dimensions Are Out-to-Out of Bearing Bars**

No. of Bars	2	3	4	5	6	7	8	9	10	11	12	13	14	15	16
3/16" Bars	7/8	1-9/16	2-1/4	2-15/16	3-5/8	4-5/16	5	5-11/16	6-3/8	7-1/16	7-3/4	8-7/16	9-1/8	9-13/16	10-1/2
No. of Bars	17	18	19	20	21	22	23	24	25	26	27	28	29	30	31
3/16" Bars	11-3/16	11-7/8	12-9/16	13-1/4	13-15/16	14-5/8	15-5/16	16	16-11/16	17-3/8	18-1/16	18-3/4	19-7/16	20-1/8	20-13/16
No. of Bars	32	33	34	35	36	37	38	39	40	41	42	43	44	45	46
3/16" Bars	21-1/2	22-3/16	22-7/8	23-9/16	24-1/4	24-15/16	25-5/8	26-5/16	27	27-11/16	28-3/8	29-1/16	29-3/4	30-7/16	31-1/8
No. of Bars	47	48	49	50	51	52	53								
3/16" Bars	31-13/16	32-1/2	33-3/16	33-7/8	34-9/16	35-1/4	35-15/16								

**Add 1/4" for extended cross bars. Deduct 1/16" for 1/8" bearing bars. Standard panel widths indicated in red.

HEAVY DUTY STEEL FEATURES & BENEFITS

Features & Benefits

This type of grating is used in areas where heavy static or rolling loads are encountered including heavy vehicular truck traffic up to H-20 loading. Calculations for vehicular loadings are based on AASHTO Standard Specifications for Highway Bridges and can be calculated by our Engineering department for your specific applications.

Heavy Duty Welded carbon steel is the most popular choice where high strength is required. For those applications requiring an ADA type product, our Wheels n' Heels® product offers the strength of the standard welded grating along with a spacing which allows 1/2" to 1/4" opening between bearing bars which conforms to the provisions with the "Americans with Disabilities Act" for pedestrian and wheelchair accessibility. To round out our heavy duty line, Ohio Gratings offers our heavy duty riveted product which is the oldest grating product on the market and continues to be popular with the engineering community.



“OGI has been manufacturing heavy duty carbon steel grating since 1971.”

Whether the requirement is for stock panels or custom fabrication “Made Right and Shipped When Promised”, Ohio Gratings is the choice of a nationwide base of customers whose primary criteria are quality and service.



HEAVY DUTY STEEL PRODUCTS

Heavy Duty Welded Steel

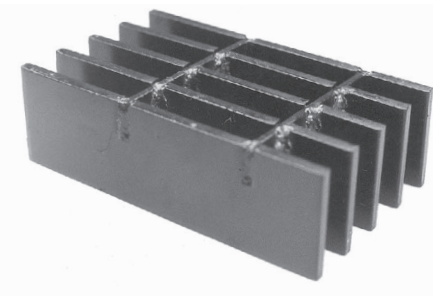

Welded carbon heavy duty steel grating is the most popular choice where high strength is the primary grating requirement. The main bars are slotted and assembled with cross bars which are welded with the one fillet weld at every joint. Stainless steel can also be provided for those high corrosive applications. This product meets the demanding vehicle loading requirements of AASHTO and is geared to handle heavy rolling loads. OnGrip® Spray Traction Surface is also available. The typical markets for heavy duty steel grating include airfields, highway bridges, ramps, docks, industrial flooring and trenches.

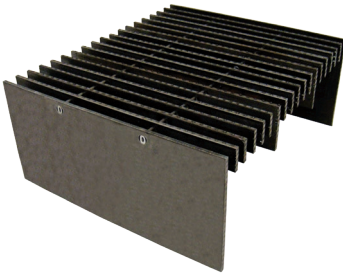

Wheels n' Heels® Heavy Duty Steel

Wheels n' Heels® is the first grating product which satisfies both the vehicle loading requirements of AASHTO and the pedestrian comfort requirements of the “Americans with Disabilities Act”. Made from Grade 36 steel bar, this product will clear span up to 8' under H15 and H20 wheel loads and can be provided in piece sizes up to 3' wide by 20' long. In addition, the close spacing of the bearing bars offers a pedestrian friendly 1/4" or 1/2" opening which allows easy access to wheelchair and high heel traffic. OnGrip® Spray Traction Surface is also available.

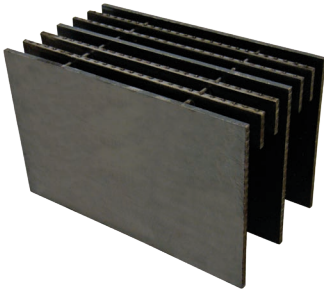

Heavy Duty Riveted Steel

The most traditional of the grating products, is our heavy duty riveted grating. It continues to be the choice of many engineers due to its reliability and durability. Bearing bars are connected with a reticuline bar to form a truss-like grid which is best suited to handle the high impact and lateral forces encountered in bridge deck applications. Riveted grating is widely used in areas which experience the dynamics of partially distributed wheel loadings. Because of its light weight and simple installation as compared to other surfaces, metal riveted bar grating permits resurfacing to handle heavier loads without the need for expensive substructure work. This material can be stocked in inventory by municipalities for quick installation. OnGrip® Spray Traction Surface is also available.

HEAVY DUTY STEEL DESIGN CRITERIA





Design Criteria

The following pages show capacities on the basis of vehicular load distribution and concentrated loading per foot of grating width for a given span. Calculations for concentrated load are similar in format to those for Light Duty Steel grating shown on page 40, except $F = 20,000$ psi. Calculations for vehicular loadings are based on AASHTO Standard Specifications for Highway Bridges and utilize the following formulas:

- | | |
|---|---|
| M = Bending Moment | a = Partial Load Contact Parallel to Span - inches |
| S = Section Modulus - in ³ /ft of grating width | s = Center-to-Center Spacing Between Bearing Bars - in. |
| I = Moment of Inertia - in ⁴ /bar | b = Partial Load Contact Dimension at 90° to Span - in. |
| E = Modulus of Elasticity (29,000,000 psi) | b = a + (2s) |
| F = Allowable Bending Stress (20,000 psi) | P = Total Wheel or Partial Load Including Load Impact - lbs. |
| L = Simple Clear Span - inches | P₁ = P per bearing bar |
| D = Deflection - inches | P₁ = P x (s/b) |

Step 1. Determine M:	$M = \frac{FS}{12}$
Step 2. Substituting for M, solve for L:	(i) $a > L$ (ii) $a < L$ $M = \frac{PL^2}{8ab}$ $M = \frac{P(.25L - .125a)}{b}$
Step 3. Check D*:	$D = \frac{P_1[(2L^3) - (a^2L) + (a^3/4)]}{96EI}$

*Deflection should be limited to 1/400 span.

Maximum Traffic Conditions	Wheel Load (lbs.) (1/2 of Axle Load + 30% Impact)	Loading	Load Distribution**	
			a	b
Truck Traffic 32,000 Lb. Axle Load Dual Wheels 	20,800	H-20	20"	20" + (2s)
Truck Traffic 24,000 Lb. Axle Load Dual Wheels 	15,600	H-15	15"	15" + (2s)
10,000 Lb. Capacity Lift Truck 14,400 Lb. Vehicle 24,400 Lb. Total Load 85% Drive Axle Load (Rubber Tires) 	13,480	5 Ton	11"	11" + (2s)
6,000 Lb. Capacity Lift Truck 9,800 Lb. Vehicle 15,800 Lb. Total Load 85% Drive Axle Load (Rubber Tires) 	8,730	3 Ton	7"	7" + (2s)
2,000 Lb. Capacity Lift Truck 4,200 Lb. Vehicle 6,200 Lb. Total Load 85% Drive Axle Load (Rubber Tires) 	3,425	1 Ton	4"	4" + (2s)

- NOTES:**
- (1) For continuous spans, use continuity factor = .80.
 - (2) This distribution results in larger grating sizes for lighter trucks on shorter spans. Spans shown for H15/H20 reflect the more critical condition.
 - (3) The fork lift wheel loads and load distribution patterns depicted above, generally, and only partially, represent the broad range of rubber-tired lift trucks available. For those applications falling outside of these examples, please contact the factory.
 - (4) Wheeled vehicles with urethane tires should NEVER be used in conjunction with open grid bar grating.
 - (5) HS20 is the same as H20 and HS15 is the same as H15. The "S" stands for semi-trailer.

Information of a technical nature contained herein is intended only for evaluation by technically skilled persons, with any use thereof to be at their independent discretion and risk. Such information is reliable when evaluated in the proper manner under conditions as described herein. Ohio Gratings, Inc. shall have no responsibility or liability for results obtained or damages resulting from improper evaluation or use.

HEAVY DUTY WELDED STEEL



W SERIES

Welded carbon heavy duty steel grating is the most popular choice where high strength is the primary grating requirement. The main bars are slotted and assembled with cross bars which are welded with one fillet weld at every joint. Stainless steel can also be provided for those high corrosive applications. This product meets the demanding vehicle loading requirements of AASHTO and is geared to handle heavy rolling loads. OnGrip® Spray Traction Surface is also available. The typical applications for our heavy duty steel products include airfield landing mats and trenches, airplane unloading ramps, highway bridge decking, sidewalks, concrete reinforcements, vault covers, ramps, docks, industrial flooring, trenches, off-shore drilling rigs and paper mills.

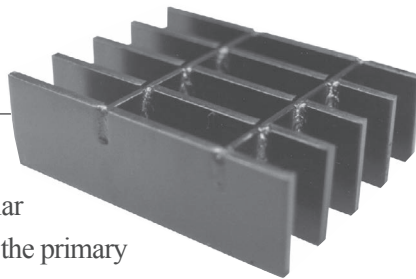

GRATING PROFILES AVAILABLE...

W SERIES Heavy Duty Welded Steel

All profiles shown below are also available with 2" cross bar centers. Product numbers would be 15-W-2, 19-W-2, 22-W-2, 30-W-2 and 38-W-2.

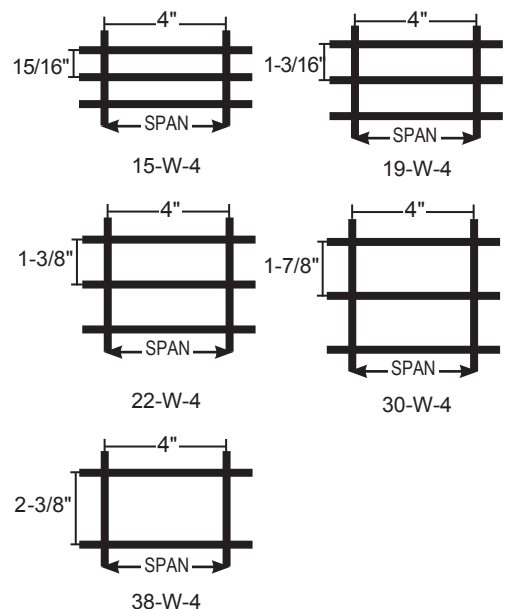

38 SPACE

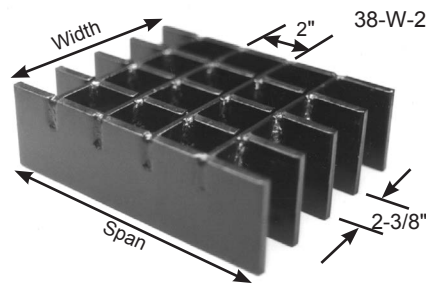
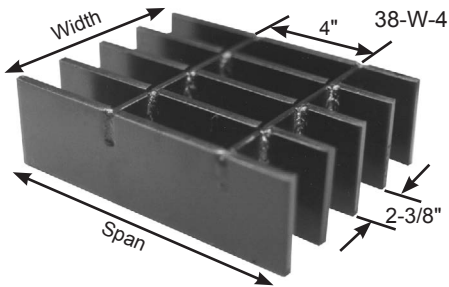

BB Size	CB Ctrs	% Open Area*			
		Bearing Bar Thickness			
		1/4"	5/16"	3/8"	1/2"
Thru 2-1/2"	4" cc	82%	80%	77%	—
	2" cc	76%	73%	71%	—
3" to 6"	4" cc	84%	82%	79%	74%
	2" cc	80%	78%	75%	71%

Bar Size, Inches	Wt.** Lbs. Sq. Ft.	Section Properties		Maximum Safe Clear Span, Inches- Partially Distributed Load			
		Sx**, in ³ Ft. Width	Ix**, in ⁴ Ft. Width	1 Ton	3 Ton	5 Ton	H15/H20
1 x 1/4	5.42	0.211	0.105	5	5	6	7
1 x 3/8	7.57	0.316	0.158	7	6	7	8
1-1/4 x 1/4	6.50	0.329	0.206	7	6	7	9
1-1/4 x 3/8	9.18	0.493	0.308	10	7	9	11
1-1/2 x 1/4	7.57	0.474	0.355	10	7	9	10
1-1/2 x 5/16	9.18	0.592	0.444	12	8	10	12
1-1/2 x 3/8	10.79	0.711	0.533	14	9	11	13
1-3/4 x 1/4	8.64	0.645	0.564	12	9	10	12
1-3/4 x 3/8	12.40	0.967	0.846	18	12	13	15
2 x 1/4	9.72	0.842	0.842	16	11	12	14
2 x 5/16	11.86	1.053	1.053	19	12	13	16
2 x 3/8	14.01	1.263	1.263	23	14	15	18
2-1/4 x 1/4	10.79	1.066	1.199	20	13	13	16
2-1/4 x 3/8	15.62	1.599	1.799	29	17	17	20
2-1/2 x 1/4	11.86	1.316	1.645	24	15	15	18
2-1/2 x 5/16	14.55	1.645	2.056	30	18	18	21
2-1/2 x 3/8	17.23	1.974	2.467	35	21	20	24
3 x 1/4	15.44	1.895	2.842	34	20	20	23
3 x 5/16	18.66	2.369	3.553	42	24	23	27
3 x 3/8	21.88	2.842	4.263	50	29	27	31
3 x 1/2	28.32	3.790	5.685	64*	37	35	39
3-1/2 x 1/4	17.58	2.579	4.513	45	26	25	29
3-1/2 x 3/8	25.10	3.869	6.770	67	38	35	40
3-1/2 x 1/2	32.62	5.158	9.027	81*	49	45	50
4 x 1/4	19.73	3.369	6.737	59	33	31	35
4 x 5/16	24.03	4.211	8.422	73	41	38	43
4 x 3/8	28.32	5.053	10.106	86*	48	44	50
4 x 1/2	36.91	6.737	13.475	96	63	57	63
4-1/2 x 1/4	21.88	4.263	9.593	74	41	38	43
4-1/2 x 3/8	31.54	6.395	14.389	96	60	55	60
4-1/2 x 1/2	41.21	8.527	19.186	96	80	71	77
5 x 1/4	24.03	5.264	13.159	91	50	46	51
5 x 5/16	29.40	6.579	16.449	96	62	56	62
5 x 3/8	34.76	7.895	19.738	96	74	66	72
5 x 1/2	45.50	10.527	26.318	96	96	87	93
5-1/2 x 1/4	26.17	6.369	17.514	96	60	55	60
5-1/2 x 3/8	37.99	9.553	26.272	96	89	79	85
5-1/2 x 1/2	49.80	12.738	35.029	96	96	96	96
6 x 1/4	28.32	7.580	22.739	96	71	64	70
6 x 5/16	34.76	9.474	28.423	96	88	79	85
6 x 3/8	41.21	11.369	34.108	96	96	94	96
6 x 1/2	54.09	15.159	45.477	96	96	96	96

*Span limited to 1/400 of span = Deflection. **Based on 5.053 bars/ft of grating width. Bearing bars 2-3/8" c.c.
 When serrated grating is specified, the depth of grating required for a specified load will be 1/4" greater than that shown in these tables. Weights shown are for 4" cross bar centers. Add 1.13 lbs./sq. ft. (3/8" Dia.) or 2.55 lbs./sq. ft. (1" x 1/4") for 2" cross bar centers. Cross bars are determined based on project applications and bearing bar height.

30 SPACE

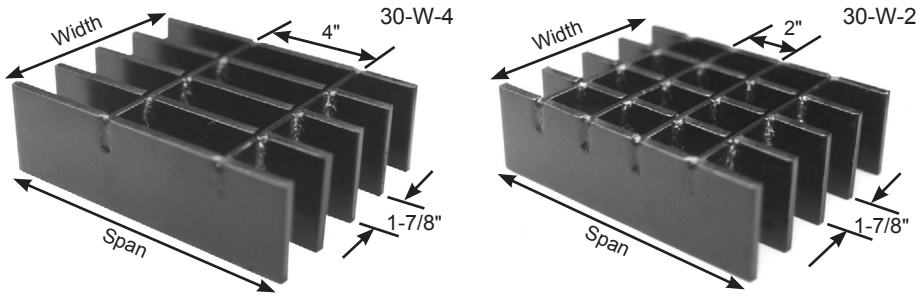

		% Open Area*			
BB Size	CB Ctrs	Bearing Bar Thickness			
		1/4"	5/16"	3/8"	1/2"
Thru 2-1/2"	4" cc	79%	76%	73%	—
	2" cc	72%	70%	67%	—
3" to 6"	4" cc	82%	78%	75%	69%
	2" cc	77%	74%	71%	65%

Bar Size, Inches	Wt.** Lbs. Sq. Ft.	Section Properties		Maximum Safe Clear Span, Inches- Partially Distributed Load			
		Sx**, in ³ Ft. Width	Ix**, in ⁴ Ft. Width	1 Ton	3 Ton	5 Ton	H15/H20
1 x 1/4	6.57	0.267	0.133	6	5	6	8
1 x 3/8	9.29	0.400	0.200	8	6	8	9
1-1/4 x 1/4	7.93	0.417	0.260	8	6	8	10
1-1/4 x 3/8	11.33	0.625	0.391	11	8	10	12
1-1/2 x 1/4	9.29	0.600	0.450	11	8	9	12
1-1/2 x 5/16	11.33	0.750	0.563	13	9	10	13
1-1/2 x 3/8	13.37	0.900	0.675	15	10	12	14
1-3/4 x 1/4	10.65	0.817	0.715	14	10	11	14
1-3/4 x 3/8	15.40	1.225	1.072	20	13	14	17
2 x 1/4	12.01	1.067	1.067	18	12	13	16
2 x 5/16	14.73	1.333	1.333	22	14	15	18
2 x 3/8	17.45	1.600	1.600	26	16	17	20
2-1/4 x 1/4	13.37	1.350	1.519	22	14	15	18
2-1/4 x 3/8	19.49	2.025	2.278	32	20	20	23
2-1/2 x 1/4	14.73	1.667	2.083	27	17	17	20
2-1/2 x 5/16	18.12	2.083	2.604	33	20	20	24
2-1/2 x 3/8	21.53	2.500	3.125	39	24	23	27
3 x 1/4	18.87	2.400	3.600	38	23	23	26
3 x 5/16	22.95	3.000	4.500	47	28	27	31
3 x 3/8	27.03	3.600	5.400	56	33	31	36
3 x 1/2	35.19	4.800	7.200	68*	42	40	45
3-1/2 x 1/4	21.59	3.267	5.717	51	30	29	33
3-1/2 x 3/8	31.11	4.900	8.575	75*	43	41	46
3-1/2 x 1/2	40.63	6.533	11.433	86*	57	53	59
4 x 1/4	24.31	4.267	8.533	66	38	36	41
4 x 5/16	29.75	5.333	10.667	82	47	44	50
4 x 3/8	35.19	6.400	12.800	91*	56	52	58
4 x 1/2	46.07	8.533	17.067	96	73	67	74
4-1/2 x 1/4	27.03	5.400	12.150	83	47	44	50
4-1/2 x 3/8	39.27	8.100	18.225	96	69	64	71
4-1/2 x 1/2	51.51	10.800	24.300	96	92	84	90*
5 x 1/4	29.75	6.667	16.667	96	58	54	60
5 x 5/16	36.55	8.333	20.833	96	71	66	73
5 x 3/8	43.35	10.000	25.000	96	85	78	86
5 x 1/2	56.95	13.333	33.333	96	96	96	96
5-1/2 x 1/4	32.47	8.067	22.183	96	69	64	71
5-1/2 x 3/8	47.43	12.100	33.275	96	96	93	96
5-1/2 x 1/2	62.39	16.133	44.367	96	96	96	96
6 x 1/4	35.19	9.600	28.800	96	82	75	83
6 x 5/16	43.35	12.000	36.000	96	96	93	96
6 x 3/8	51.51	14.400	43.200	96	96	96	96
6 x 1/2	67.83	19.200	57.600	96	96	96	96

*Span limited to 1/400 of span = Deflection. **Based on 6.4 bars/ft of grating width. Bearing bars 1-7/8" c.c.
 When serrated grating is specified, the depth of grating required for a specified load will be 1/4" greater than that shown in these tables. Weights shown are for 4" cross bar centers. Add 1.13 lbs./sq. ft. (3/8" Dia.) or 2.55 lbs./sq. ft. (1" x 1/4") for 2" cross bar centers. Cross bars are determined based on project applications and bearing bar height.

22 SPACE

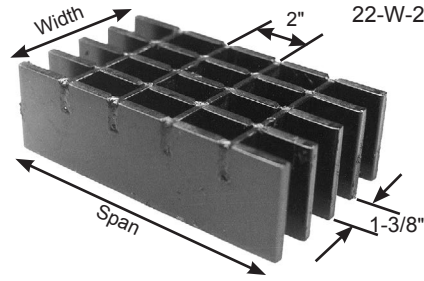
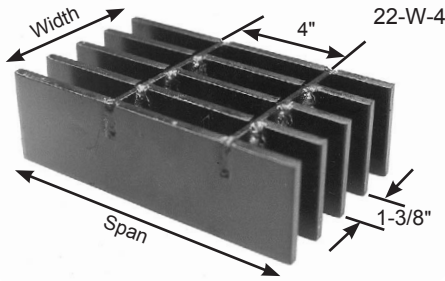

BB Size	CB Ctrs	% Open Area*			
		Bearing Bar Thickness			
		1/4"	5/16"	3/8"	1/2"
Thru	4" cc	75%	70%	66%	—
2-1/2"	2" cc	68%	64%	60%	—
3" to	4" cc	77%	72%	68%	60%
6"	2" cc	72%	68%	64%	56%

Bar Size, Inches	Wt.** Lbs. Sq. Ft.	Section Properties		Maximum Safe Clear Span, Inches- Partially Distributed Load			
		Sx**, in ³ Ft. Width	Ix**, in ⁴ Ft. Width	1 Ton	3 Ton	5 Ton	H15/H20
1 x 1/4	8.54	0.364	0.182	6	6	7	9
1 x 3/8	12.25	0.545	0.273	9	7	9	11
1-1/4 x 1/4	10.40	0.568	0.355	9	7	9	11
1-1/4 x 3/8	15.04	0.852	0.533	13	9	11	13
1-1/2 x 1/4	12.25	0.818	0.614	12	9	11	13
1-1/2 x 5/16	15.04	1.023	0.767	15	11	12	15
1-1/2 x 3/8	17.82	1.227	0.920	18	12	13	16
1-3/4 x 1/4	14.11	1.114	0.974	16	11	13	15
1-3/4 x 3/8	20.59	1.670	1.462	23	15	16	20
2 x 1/4	15.96	1.455	1.455	21	14	15	18
2 x 5/16	19.67	1.818	1.818	25	17	17	21
2 x 3/8	23.38	2.182	2.182	30	19	20	24
2-1/4 x 1/4	17.82	1.841	2.071	26	17	18	21
2-1/4 x 3/8	26.16	2.761	3.106	38	24	24	28
2-1/2 x 1/4	19.67	2.273	2.841	31	20	20	24
2-1/2 x 5/16	24.30	2.841	3.551	39	24	24	29
2-1/2 x 3/8	28.95	3.409	4.261	46	28	28	33
3 x 1/4	24.80	3.273	4.909	45	27	27	32
3 x 5/16	30.37	4.091	6.136	55	33	33	38
3 x 3/8	35.93	4.909	7.363	64*	40	38	44
3 x 1/2	47.06	6.545	9.818	74*	52	50	57*
3-1/2 x 1/4	28.51	4.454	7.795	60	36	35	41
3-1/2 x 3/8	41.50	6.682	11.693	81*	53	50	58
3-1/2 x 1/2	54.48	8.909	15.590	94*	69	66	71*
4 x 1/4	32.22	5.818	11.636	78	46	45	51
4 x 5/16	39.64	7.273	14.545	91*	57	54	62
4 x 3/8	47.06	8.727	17.454	96	68	64	73
4 x 1/2	61.89	11.636	23.272	96	86*	83*	87*
4-1/2 x 1/4	35.93	7.363	16.568	96	58	55	63
4-1/2 x 3/8	52.63	11.045	24.851	96	85	80	89*
4-1/2 x 1/2	69.31	14.727	33.135	96	96	96	96
5 x 1/4	39.64	9.091	22.727	96	71	67	76
5 x 5/16	48.92	11.363	28.408	96	88	82	92
5 x 3/8	58.18	13.636	34.090	96	96	96	96
5 x 1/2	76.73	18.181	45.453	96	96	96	96
5-1/2 x 1/4	43.35	11.000	30.249	96	85	80	90
5-1/2 x 3/8	63.75	16.499	45.374	96	96	96	96
5-1/2 x 1/2	84.15	21.999	60.498	96	96	96	96
6 x 1/4	47.06	13.091	39.272	96	96	94	96
6 x 5/16	58.18	16.363	49.089	96	96	96	96
6 x 3/8	69.31	19.636	58.907	96	96	96	96
6 x 1/2	91.57	26.181	78.543	96	96	96	96

*Span limited to 1/400 of span = Deflection. **Based on 8.727 bars/ft of grating width. Bearing bars 1-3/8" c.c.
 When serrated grating is specified, the depth of grating required for a specified load will be 1/4" greater than that shown in these tables. Weights shown are for 4" cross bar centers. Add 1.13 lbs./sq. ft. (3/8" Dia.) or 2.55 lbs./sq. ft. (1" x 1/4") for 2" cross bar centers. Cross bars are determined based on project applications and bearing bar height.

19 SPACE

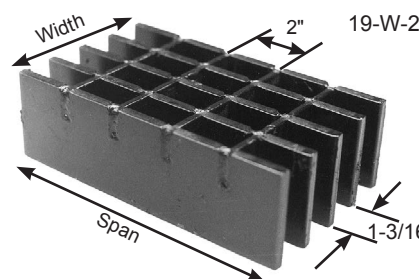
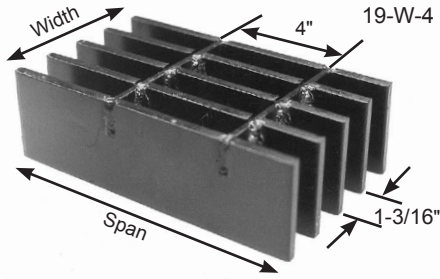

		% Open Area*			
BB Size	CB Ctrs	Bearing Bar Thickness			
		1/4"	5/16"	3/8"	1/2"
Thru 2-1/2"	4" cc	72%	67%	62%	—
	2" cc	65%	61%	56%	—
3" to 6"	4" cc	74%	69%	64%	54%
	2" cc	70%	65%	60%	51%

Bar Size, Inches	Wt.** Lbs. Sq. Ft.	Section Properties		Maximum Safe Clear Span, Inches- Partially Distributed Load			
		Sx**, in ³ Ft. Width	Ix**, in ⁴ Ft. Width	1 Ton	3 Ton	5 Ton	H15/H20
1 x 1/4	9.71	0.421	0.211	7	6	7	9
1 x 3/8	14.01	0.632	0.316	9	8	9	11
1-1/4 x 1/4	11.87	0.658	0.411	10	8	9	12
1-1/4 x 3/8	17.23	0.987	0.617	14	10	12	14
1-1/2 x 1/4	14.01	0.947	0.711	13	10	11	14
1-1/2 x 5/16	17.23	1.184	0.888	16	11	13	16
1-1/2 x 3/8	20.46	1.421	1.066	19	13	14	18
1-3/4 x 1/4	16.16	1.289	1.128	17	12	14	17
1-3/4 x 3/8	23.67	1.934	1.692	25	17	18	21
2 x 1/4	18.30	1.684	1.684	22	15	16	20
2 x 5/16	22.60	2.105	2.105	28	18	19	23
2 x 3/8	26.89	2.526	2.526	33	21	22	26
2-1/4 x 1/4	20.46	2.132	2.398	28	18	19	23
2-1/4 x 3/8	30.12	3.197	3.597	41	26	26	31
2-1/2 x 1/4	22.60	2.632	3.289	34	22	22	27
2-1/2 x 5/16	27.96	3.289	4.112	42	27	27	31
2-1/2 x 3/8	33.34	3.947	4.934	50	31	31	36
3 x 1/4	28.32	3.789	5.684	49	30	30	35
3 x 5/16	34.76	4.737	7.105	60	37	36	42
3 x 3/8	41.20	5.684	8.526	67*	44	43	49
3 x 1/2	54.09	7.579	11.368	78*	57	55	61*
3-1/2 x 1/4	32.61	5.158	9.026	66	40	39	45
3-1/2 x 3/8	47.65	7.737	13.539	85*	58	56	64
3-1/2 x 1/2	62.67	10.316	18.052	96	75*	72*	76*
4 x 1/4	36.91	6.737	13.473	85*	51	50	57
4 x 5/16	45.50	8.421	16.842	95*	63	61	70
4 x 3/8	54.09	10.105	20.210	96	75	72	80*
4 x 1/2	71.26	13.473	26.947	96	91*	88*	92*
4-1/2 x 1/4	41.20	8.526	19.184	96	64	61	70
4-1/2 x 3/8	60.53	12.789	28.776	96	94*	90	95*
4-1/2 x 1/2	79.85	17.052	38.367	96	96	96	96
5 x 1/4	45.50	10.526	26.315	96	78	75	85
5 x 5/16	56.24	13.158	32.894	96	96	92	96
5 x 3/8	66.97	15.789	39.473	96	96	96	96
5 x 1/2	88.44	21.052	52.630	96	96	96	96
5-1/2 x 1/4	49.79	12.737	35.025	96	94	89	96
5-1/2 x 3/8	73.42	19.105	52.538	96	96	96	96
5-1/2 x 1/2	97.03	25.473	70.051	96	96	96	96
6 x 1/4	54.09	15.158	45.473	96	96	96	96
6 x 5/16	66.97	18.947	56.841	96	96	96	96
6 x 3/8	79.85	22.736	68.209	96	96	96	96
6 x 1/2	105.62	30.315	90.945	96	96	96	96

*Span limited to 1/400 of span = Deflection. **Based on 10.105 bars/ft of grating width. Bearing bars 1-3/16" c.c.
 When serrated grating is specified, the depth of grating required for a specified load will be 1/4" greater than that shown in these tables. Weights shown are for 4" cross bar centers. Add 1.13 lbs./sq. ft. (3/8" Dia.) or 2.55 lbs./sq. ft. (1" x 1/4") for 2" cross bar centers. Cross bars are determined based on project applications and bearing bar height.

15 SPACE

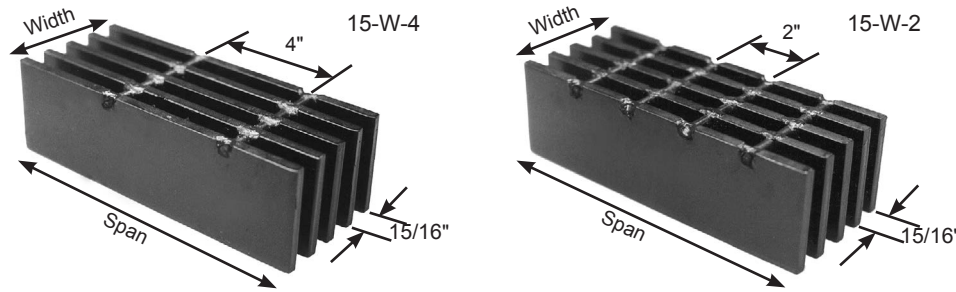

% Open Area*				
BB Size	CB Ctrs	Bearing Bar Thickness		
		1/4"	5/16"	3/8"
Thru 4"	cc	66%	60%	54%
2-1/2"	2" cc	60%	55%	49%
3" to 6"	4" cc	69%	62%	56%
	2" cc	64%	58%	53%

Bar Size, Inches	Wt.** Lbs. Sq. Ft.	Section Properties		Maximum Safe Clear Span, Inches- Partially Distributed Load			
		Sx**, in ³ Ft. Width	Ix**, in ⁴ Ft. Width	1 Ton	3 Ton	5 Ton	H15/H20
1 x 1/4	12.01	0.533	0.267	8	7	8	10
1 x 3/8	17.45	0.800	0.400	11	8	10	13
1-1/4 x 1/4	14.73	0.833	0.521	11	9	10	13
1-1/4 x 3/8	21.53	1.250	0.781	16	11	13	16
1-1/2 x 1/4	17.45	1.200	0.900	15	11	13	16
1-1/2 x 5/16	21.53	1.500	1.125	19	13	15	18
1-1/2 x 3/8	25.61	1.800	1.350	22	15	16	20
1-3/4 x 1/4	20.17	1.633	1.429	20	14	15	19
1-3/4 x 3/8	29.68	2.450	2.144	30	20	21	25
2 x 1/4	22.89	2.133	2.133	26	17	19	22
2 x 5/16	28.33	2.667	2.667	32	21	22	26
2 x 3/8	33.77	3.200	3.200	38	25	25	30
2-1/4 x 1/4	25.61	2.700	3.038	32	21	22	26
2-1/4 x 3/8	37.85	4.050	4.556	47*	30	31	36
2-1/2 x 1/4	28.33	3.333	4.167	40	26	26	31
2-1/2 x 5/16	35.12	4.167	5.208	49	31	32	37
2-1/2 x 3/8	41.93	5.000	6.250	55*	37	37	43
3 x 1/4	35.19	4.800	7.200	56	36	36	42
3 x 5/16	43.36	6.000	9.000	66*	44	43	50
3 x 3/8	51.51	7.200	10.800	73*	52	51	59*
3-1/2 x 1/4	40.63	6.533	11.433	75*	47	47	54
3-1/2 x 3/8	59.68	9.800	17.150	92*	69	67	73*
4 x 1/4	46.07	8.533	17.067	92*	61	59	69
4 x 5/16	56.95	10.667	21.333	96	75	73	81*
4 x 3/8	67.83	12.800	25.600	96	87*	84*	89*
4-1/2 x 1/4	51.51	10.800	24.300	96	76	74	85
4-1/2 x 3/8	76.00	16.200	36.450	96	96	96	96
5 x 1/4	56.95	13.333	33.333	96	93	90	96
5 x 5/16	70.56	16.667	41.667	96	96	96	96
5 x 3/8	84.15	20.000	50.000	96	96	96	96
5-1/2 x 1/4	62.39	16.133	44.367	96	96	96	96
5-1/2 x 3/8	92.32	24.200	66.550	96	96	96	96
6 x 1/4	67.83	19.200	57.600	96	96	96	96
6 x 5/16	84.15	24.000	72.000	96	96	96	96
6 x 3/8	100.47	28.800	86.400	96	96	96	96

*Span limited to 1/400 of span = Deflection. **Based on 12.8 bars/ft of grating width. Bearing bars 15/16" c.c. **Note:** When serrated grating is specified, the depth of grating required for a specified load will be 1/4" greater than that shown in these tables. Weights shown are for 4" cross bar centers. Add 1.13 lbs./sq. ft. (3/8" Dia.) or 2.55 lbs./sq. ft. (1" x 1/4") for 2" cross bar centers. Cross bars are determined based on project applications and bearing bar height.

STEEL GRATING FRAMES

GRATING FRAMES

Embed frames cast into concrete floors and substructures serve a multitude of purposes that extend the life of any project where open flooring is required. Steel frames form a permanent shield for concrete lead edges and perimeters which are subject to cracking and chipping when left unprotected. During construction these rigid frames expedite forming and provide a welded structure that assures accuracy in the concrete pour. Frames provide a uniform bearing surface for all our grating products and help eliminate the potential for rocking or irregular elevations experienced when only covers are installed on poured concrete.

All frames are available in four sided, one piece construction units and can accommodate any clear opening. Long lengths can be provided with fabricated corners for field installation when required. Frames can be provided mill finished, galvanized or with a powder coat black finish. All our steel frames are provided with 3/8" x 4" headed concrete stud anchors welded within 6" of each corner and at a maximum of 24" on center.

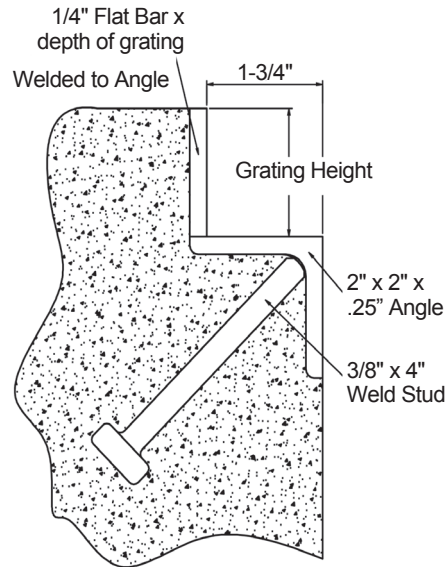

Light Duty

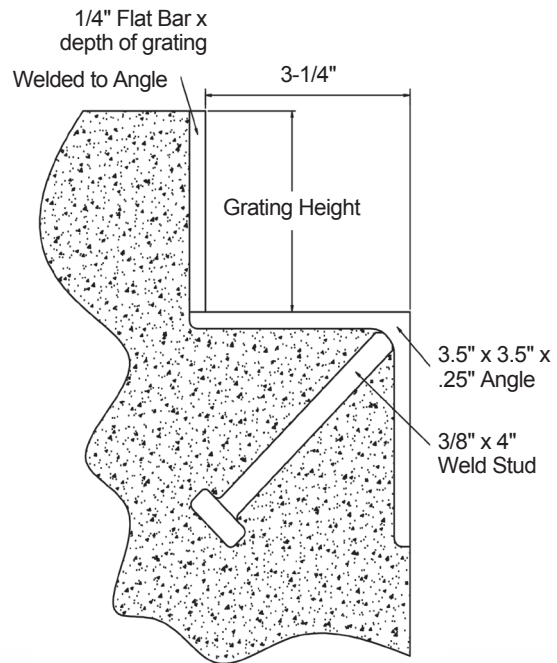

Heavy Duty

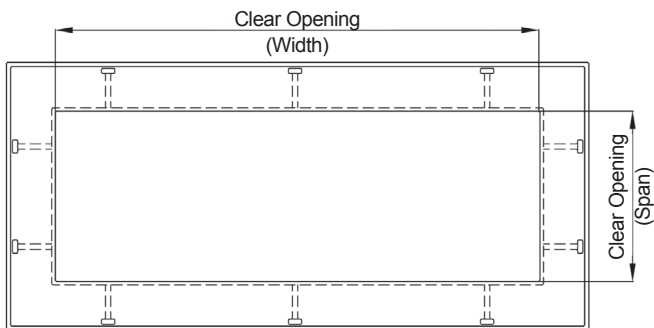

Frames are available as one piece welded construction or individual pieces

HEAVY DUTY Wheels n' Heels®



Wheels n' Heels® is the first grating product which satisfies both the vehicular loading requirements of AASHTO and the pedestrian comfort requirements of the “Americans with Disabilities Act”. Made from carbon or stainless steel, our newest versions, Metro® and InVent®, weigh less than other products in the marketplace and are more aesthetically appealing. OnGrip® Spray Traction Surface is also available. Check with our Sales Representatives for specific piece size limits on each type and size.

Applications for these products include:

- City Utility Vaults
- MTA Applications
- Parks & Recreation
- Tree Grates
- Pedestrian Bridges
- Piers

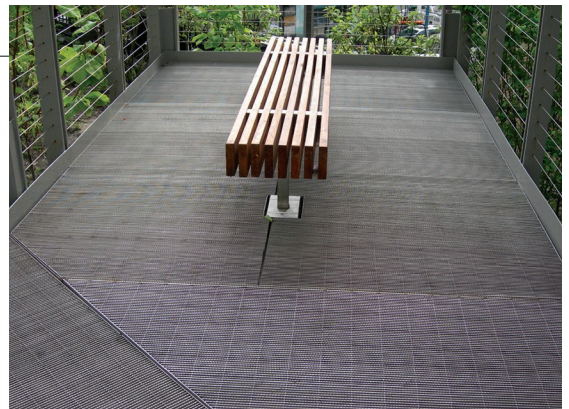

HEAVY DUTY Wheels n' Heels® Metro®



METRO®

The new **Wheels n' Heels® Metro®** has an even greater strength to weight ratio, and much improved aesthetic appeal, since there are now no welds on the top surface. In addition, the filler bars and main bearing bars are both the same thickness thus providing increased percent open area. Included in this new line are types with spacing of 1/2" between the bars to meet ADA requirements as well as types with spacing of 1/4" between bars to accommodate High Heel pedestrian use. **Wheels n' Heels® Metro®** is also bicycle friendly. Also available in Stainless Steel upon request.

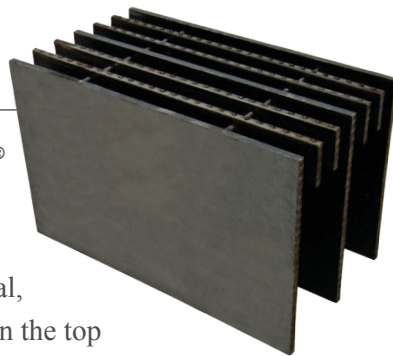

OnGrip® Spray Traction Surface is recommended to meet ADA guidelines.

GRATING PROFILES AVAILABLE... Heavy Duty Wheels n' Heels® METRO®

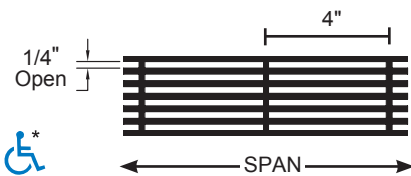

28-WH-4* & 42-WH-4*

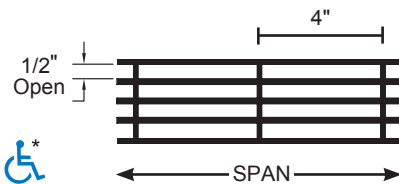

33-WH-4* & 44-WH-4*

*Note: Conforms with the spacing requirements of ADA (September 2010) when installed with the elongated opening perpendicular to the dominant direction of travel. See ADA Guidelines

Wheels n' Heels® Metro® 28-WH-4 Grade 50 Carbon Steel

Bicycle Friendly

Banding Optional ▶

This grating meets ANSI/NAAMM MBG - 532, ADA & High Heel spacing & AASHTO H20/H15 standards.

A OnGrip® Spray Traction Surface is recommended to meet ADA guidelines.

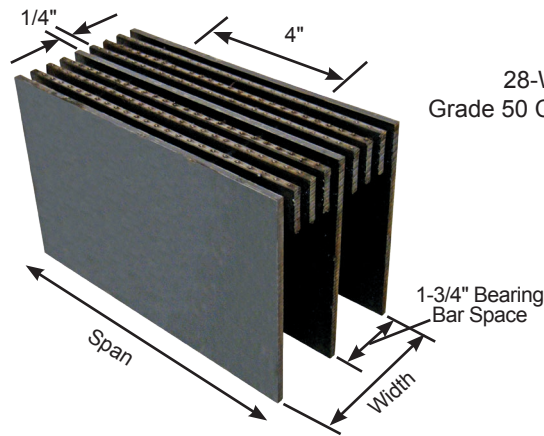

28-WH-4
Grade 50 Carbon Steel

% Open Area*
52%

with 1/4" opening between bearing or filler bars.

Main Bearing Bar Size Inches	Weight Lbs. Sq. Ft.	Section Properties		Cross Bar Size, Inches	Maximum Safe ClearSpan , Inches - Partially Distributed Load				Maximum Manufactured Spans Inches
		Sx, in ³ Ft. Width	Ix, in ⁴ Ft. Width		Lift truck Capacity			AASHTO	
					1 Ton	3 Ton	5 Ton	H15/H20	
3 x 3/16	28.17	1.929	2.893	1 x 1/8	40	24	24	28	288
3-1/2 x 3/16	30.36	2.625	4.594	1 x 1/8	54	32	31	36	288
4 x 3/16	32.55	3.429	6.857	1 x 1/8	66 *	40 *	39	44	288
4-1/2 x 3/16	34.74	4.339	9.763	1 x 1/8	78 *	47 *	48	54	288
5 x 3/16	36.93	5.357	13.393	1 x 1/8	92 *	55 *	57	64	288
6 x 3/16	41.31	7.714	23.143	1 x 1/8	96 *	72 *	80	88	288

*Span limited based on L / 400 max deflection or 96" max span

Main Bearing Bar Size, Inches	Maximum Safe Concentrated Load, Lbs./Ft. Width - at ClearSpan										
	2'- 0"	2'- 6"	3'- 0"	3'- 6"	4'- 0"	4'- 6"	5'- 0"	5'- 6"	6'- 0"	7'- 0"	8'- 0"
3 x 3/16	8679	6943	5786	4959	4339						
3-1/2 x 3/16	11813	9450	7875	6750	5906	5250					
4 x 3/16	15429	12343	10286	8816	7714	6857	6171				
4-1/2 x 3/16	19527	15621	13018	11158	9763	8679	7811	7101	6509		
5 x 3/16	24107	19286	16071	13776	12054	10714	9643	8766	8036		
6 x 3/16	34714	27771	23143	19837	17357	15429	13886	12623	11571	9918	8679

Loads given are theoretical and based on a unit stress of 27,000 psi.

Panel Width Chart (in.) - 28-WH-4		Dimensions Are Out-to-Out of Bearing Bars														
No. of Bars		2	3	4	5	6	7	8	9	10	11	12	13	14	15	16
3/16" Bars		1-15/16	3-11/16	5-7/16	7-3/16	8-15/16	10-11/16	12-7/16	14-3/16	15-15/16	17-11/16	19-7/16	21-3/16	22-15/16	24-11/16	26-7/16
No. of Bars		17	18	19	20	21	22	23	24							
3/16" Bars		28-3/16	29-15/16	31-11/16	33-7/16	35-3/16	36-15/16	38-11/16	40-7/16							

Wheels n' Heels® Metro® 33-WH-4 Grade 50 Carbon Steel

Bicycle Friendly

Banding Optional ▶

This grating meets ANSI/NAAMM MBG - 532, ADA spacing & AASHTO H20/H15 standards.

A OnGrip® Spray Traction Surface is recommended to meet ADA guidelines.

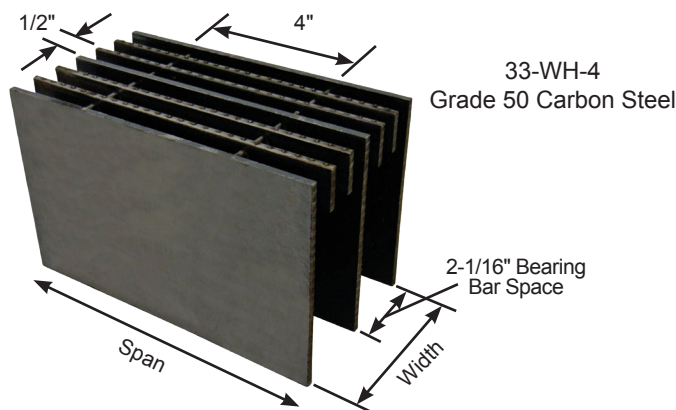

% Open Area*

67%

with 1/2" opening between bearing or filler bars.

Main Bearing Bar Size Inches	Weight Lbs. Sq. Ft.	Section Properties		Cross Bar Size, Inches	Maximum Safe ClearSpan , Inches- Partially Distributed Load				Maximum Manufactured Spans Inches
		Sx, in ³ Ft. Width	Ix, in ⁴ Ft. Width		Lift truck Capacity			AASHTO H15/H20	
					1 Ton	3 Ton	5 Ton		
3 x 3/16	20.47	1.636	2.455	1 x 1/8	37	22	22	26	288
3-1/2 x 3/16	22.33	2.227	3.898	1 x 1/8	50	29	28	32	288
4 x 3/16	24.19	2.909	5.818	1 x 1/8	63 *	37	35	40	288
4-1/2 x 3/16	26.04	3.682	8.284	1 x 1/8	75 *	45 *	43	48	288
5 x 3/16	27.90	4.545	11.364	1 x 1/8	88 *	52 *	51	57	288
6 x 3/16	31.62	6.545	19.636	1 x 1/8	96 *	69 *	72	78	288
7 x 3/16	35.34	8.909	31.182	1 x 1/8	96 *	86 *	95	96 *	288

*Span limited based on L / 400 max deflection or 96" max span

Main Bearing Bar Size Inches	Maximum Safe Concentrated Load, Lbs./Ft. Width - at ClearSpan										
	2'- 0"	2'- 6"	3'- 0"	3'- 6"	4'- 0"	4'- 6"	5'- 0"	5'- 6"	6'- 0"	7'- 0"	8'- 0"
3 x 3/16	7364	5891	4909	4208	3682						
3-1/2 x 3/16	10023	8018	6682	5727	5011	4455					
4 x 3/16	13091	10473	8727	7481	6545	5818	5236				
4-1/2 x 3/16	16568	13255	11045	9468	8284	7364	6627	6025	5523		
5 x 3/16	20455	16364	13636	11688	10227	9091	8182	7438	6818		
6 x 3/16	29455	23564	19636	16831	14727	13091	11782	10711	9818	8416	7364
7 x 3/16	40091	32073	26727	22909	20045	17818	16036	14579	13364	11455	10023

Loads given are theoretical and based on a unit stress of 27,000 psi.

Panel Width Chart (in.) - 33-WH-4 **Dimensions Are Out-to-Out of Bearing Bars**

No. of Bars	2	3	4	5	6	7	8	9	10	11	12	13	14	15	16
3/16" Bars	2-1/4	4-5/16	6-3/8	8-7/16	10-1/2	12-9/16	14-5/8	16-11/16	18-3/4	20-13/16	22-7/8	24-15/16	27	29-1/16	31-1/8
No. of Bars	17	18	19												
3/16" Bars	33-3/16	35-1/4	37-5/16												

Wheels n' Heels® Metro® 42-WH-4 Grade 50 Carbon Steel

Bicycle Friendly

Banding Optional ▶

This grating meets ANSI/NAAMM MBG - 532, ADA & High Heel spacing & AASHTO H20/H15 standards.

A OnGrip® Spray Traction Surface is recommended to meet ADA guidelines.

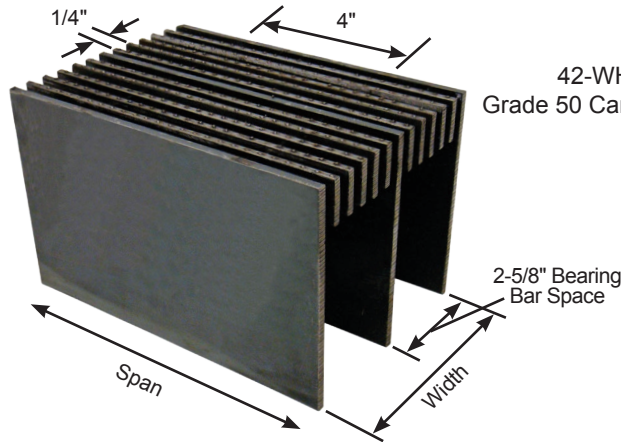

42-WH-4
Grade 50 Carbon Steel

% Open Area*
52%

with 1/4" opening between bearing or filler bars.

Main Bearing Bar Size Inches	Weight Lbs. Sq. Ft.	Section Properties		Cross Bar Size, Inches	Maximum Safe ClearSpan , Inches-Partially Distributed Load				Maximum Manufactured Spans Inches
		Sx, in ³ Ft. Width	Ix, in ⁴ Ft. Width		Lift truck Capacity			AASHTO	
					1 Ton	3 Ton	5 Ton	H15/H20	
3 x 3/16	25.25	1.286	1.929	1 x 1/8	33	20	19	23	288
3-1/2 x 3/16	26.71	1.750	3.063	1 x 1/8	45	26	24	28	288
4 x 3/16	28.17	2.286	4.571	1 x 1/8	58	32	30	34	288
4-1/2 x 3/16	29.63	2.893	6.509	1 x 1/8	71 *	40	37	41	288
5 x 3/16	31.09	3.571	8.929	1 x 1/8	83 *	49	44	49	288
6 x 3/16	34.01	5.143	15.429	1 x 1/8	96 *	64 *	61	66	288
7 x 3/16	36.93	7.000	24.500	1 x 1/8	96 *	80 *	81	86	288

*Span limited based on L / 400 max deflection or 96" max span

Main Bearing Bar Size Inches	Maximum Safe Concentrated Load, Lbs./Ft. Width - at ClearSpan										
	2'- 0"	2'- 6"	3'- 0"	3'- 6"	4'- 0"	4'- 6"	5'- 0"	5'- 6"	6'- 0"	7'- 0"	8'- 0"
3 x 3/16	5786	4629	3857	3306	2893						
3-1/2 x 3/16	7875	6300	5250	4500	3938	3500					
4 x 3/16	10286	8229	6857	5878	5143	4571	4114				
4-1/2 x 3/16	13018	10414	8679	7439	6509	5786	5207	4734	4339		
5 x 3/16	16071	12857	10714	9184	8036	7143	6429	5844	5357		
6 x 3/16	23143	18514	15429	13224	11571	10286	9257	8416	7714	6612	5786
7 x 3/16	31500	25200	21000	18000	15750	14000	12600	11455	10500	9000	7875

Loads given are theoretical and based on a unit stress of 27,000 psi.

Panel Width Chart (in.) - 42-WH-4		Dimensions Are Out-to-Out of Bearing Bars														
No. of Bars		2	3	4	5	6	7	8	9	10	11	12	13	14	15	16
3/16" Bars		2-13/16	5-7/16	8-1/16	10-11/16	13-5/16	15-15/16	18-9/16	21-3/16	23-13/16	26-7/16	29-1/16	31-11/16	34-5/16	36-15/16	39-9/16

Wheels n' Heels® Metro® 44-WH-4 Grade 50 Carbon Steel

Bicycle Friendly

Banding Optional ▶

This grating meets ANSI/NAAMM MBG - 532, ADA spacing & AASHTO H20/H15 standards.

A OnGrip® Spray Traction Surface is recommended to meet ADA guidelines.

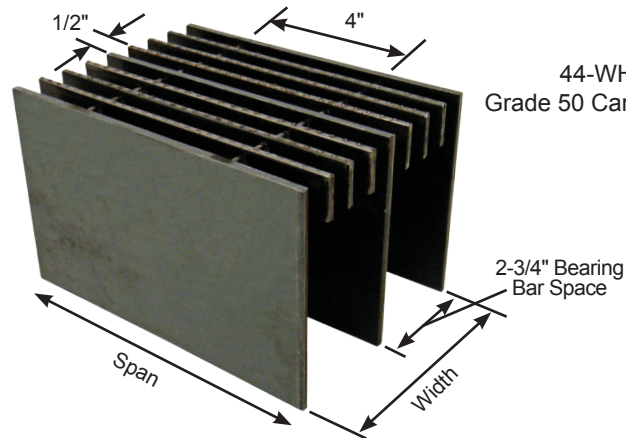

44-WH-4
Grade 50 Carbon Steel

% Open Area*

67%

with 1/2" opening
between bearing or
filler bars.

Main Bearing Bar Size Inches	Weight Lbs. Sq. Ft.	Section Properties		Cross Bar Size, Inches	Maximum Safe ClearSpan , Inches- Partially Distributed Load				Maximum Manufactured Spans Inches
		Sx, in ³ Ft. Width	Ix, in ⁴ Ft. Width		Lift truck Capacity			AASHTO H15/H20	
					1 Ton	3 Ton	5 Ton		
3 x 3/16	18.61	1.227	1.841	1 x 1/8	33	19	19	22	288
3-1/2 x 3/16	20.00	1.670	2.923	1 x 1/8	44	25	24	27	288
4 x 3/16	21.40	2.182	4.364	1 x 1/8	56	32	30	33	288
4-1/2 x 3/16	22.79	2.761	6.213	1 x 1/8	70 *	39	36	40	288
5 x 3/16	24.19	3.409	8.523	1 x 1/8	82 *	47	43	48	288
6 x 3/16	26.97	4.909	14.727	1 x 1/8	96 *	63 *	60	64	288
7 x 3/16	29.76	6.682	23.386	1 x 1/8	96 *	79 *	79	84	288

*Span limited based on L / 400 max deflection or 96" max span.

Main Bearing Bar Size Inches	Maximum Safe Concentrated Load, Lbs./Ft. Width - at ClearSpan										
	2'- 0"	2'- 6"	3'- 0"	3'- 6"	4'- 0"	4'- 6"	5'- 0"	5'- 6"	6'- 0"	7'- 0"	8'- 0"
3 x 3/16	5523	4418	3682	3156	2761						
3-1/2 x 3/16	7517	6014	5011	4295	3759	3341					
4 x 3/16	9818	7855	6545	5610	4909	4364	3927				
4-1/2 x 3/16	12426	9941	8284	7101	6213	5523	4970	4519	4142		
5 x 3/16	15341	12273	10227	8766	7670	6818	6136	5579	5114		
6 x 3/16	22091	17673	14727	12623	11045	9818	8836	8033	7364	6312	5523
7 x 3/16	30068	24055	20045	17182	15034	13364	12027	10934	10023	8591	7517

Loads given are theoretical and based on a unit stress of 27,000 psi.

Panel Width Chart (in.) - 44-WH-4 **Dimensions Are Out-to-Out of Bearing Bars**

No. of Bars	2	3	4	5	6	7	8	9	10	11	12	13	14	15	16
3/16" Bars	2-15/16	5-11/16	8-7/16	11-3/16	13-15/16	16-11/16	19-7/16	22-3/16	24-15/16	27-11/16	30-7/16	33-3/16	35-15/16	38-11/16	

HEAVY DUTY Wheels n' Heels® InVent®



InVent®

The **Wheels n' Heels® InVent®** is the newest addition to the **Wheels n' Heels®** family of grate products. This product type offers the same high strength to weight ratio, excellent appearance and compliance with AASHTO and ADA and High Heel requirements as the Metro® type along with being bicycle friendly. The major difference with the **InVent®** style is that the main support bearing bars are hidden under the top surface bars and run in the direction perpendicular to the top surface bars. This feature allows us to offer you the most flexibility in product types to fit the grating supports of your project. Also available in Stainless Steel upon request.

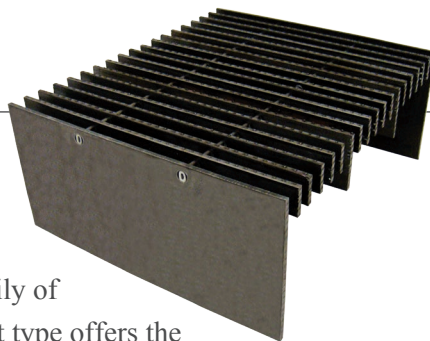

GRATING PROFILES AVAILABLE... Heavy Duty Wheels n' Heels® InVent®

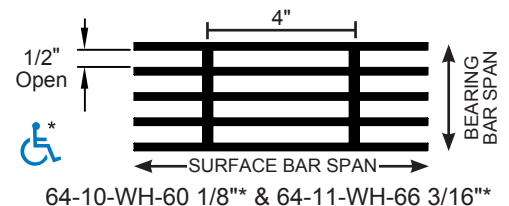
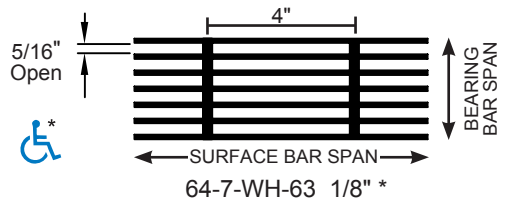
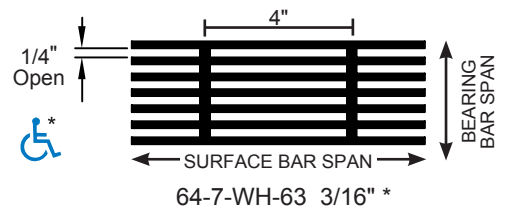

*Note: Conforms with the spacing requirements of ADA (September 2010) when installed with the elongated opening perpendicular to the dominant direction of travel. See ADA Guidelines

OnGrip® Spray Traction Surface is recommended to meet ADA guidelines.

Wheels n' Heels® InVent® 64-7-WH-63 1/8" Grade 50 Carbon Steel

Bicycle Friendly

Banding Optional ▶

This grating meets ANSI/NAAMM MBG - 532, ADA & High heel spacing & AASHTO H20/H15 standards.

A OnGrip® Spray Traction Surface is recommended to meet ADA guidelines.

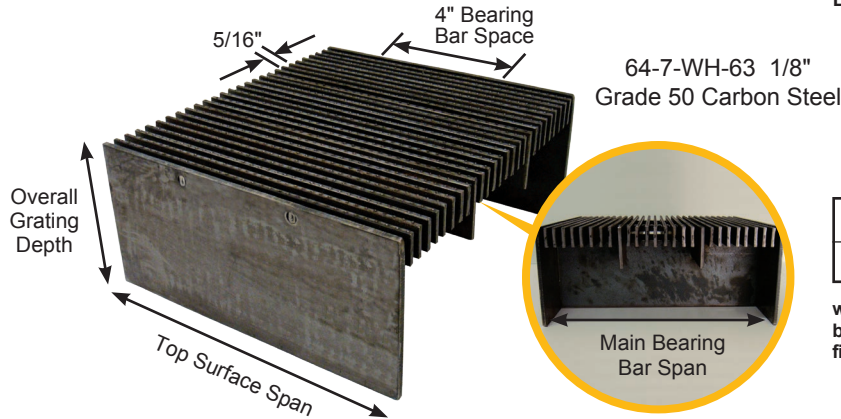

% Open Area*
66%

with 5/16" opening between bearing or filler bars.

Main bearing bars are concealed below the swaged panel.

Size, Overall Grating Depth Inches	Main Bearing Bar Inches Grade 50	Weight Lbs./ Sq. Ft.	Section Properties		Top Surface Bar Size, Inches	Maximum Safe ClearSpan, Inches- Partially Distributed Load				Maximum Manufactured Span Top Surface Bars Inches
			Sx, in³ Ft. Width	Ix, in⁴ Ft. Width		Lift Truck Capacity			AASHTO H15/H20	
						1 Ton	3 Ton	5 Ton		
2-1/2	1-1/2 x 1/4	16.69	0.281	0.211	1 x 1/8	11	8	9	11	288
3	2 x 1/4	17.97	0.500	0.500	1 x 1/8	18	11	12	14	288
3-1/2	2-1/2 x 1/4	19.24	0.781	0.977	1 x 1/8	27	16	15	18	288
4	3 x 1/4	20.52	1.125	1.688	1 x 1/8	37	21	20	22	288
4-1/2	3-1/2 x 1/4	21.80	1.531	2.680	1 x 1/8	50	27	25	28	288
5	4 x 1/4	23.08	2.000	4.000	1 x 1/8	63 *	34	31	34	288
5-1/2	4-1/2 x 1/4	24.36	2.531	5.695	1 x 1/8	76 *	43	38	41	288
6	5 x 1/4	25.63	3.125	7.813	1 x 1/8	89 *	50 *	45	48	288
6-1/2	5-1/2 x 1/4	26.91	3.781	10.398	1 x 1/8	96 *	58 *	53	56	288
7	6 x 1/4	28.19	4.500	13.500	1 x 1/8	96 *	66 *	63	65	288
8	7 x 1/4	30.75	6.125	21.438	1 x 1/8	96 *	83 *	83	84	288

*Span limited based on L / 400 max deflection or 96" max span.

Size Inches	Main Bearing Bar Inches	Maximum Safe Concentrated Load, Lbs./Ft. Width - at ClearSpan											
		2'- 0"	2'- 6"	3'- 0"	3'- 6"	4'- 0"	4'- 6"	5'- 0"	5'- 6"	6'- 0"	7'- 0"	8'- 0"	
2-1/2	1-1/2 x 1/4	1266											
3	2 x 1/4	2250	1800										
3-1/2	2-1/2 x 1/4	3516	2813	2344									
4	3 x 1/4	5063	4050	3375	2893	2531							
4-1/2	3-1/2 x 1/4	6891	5513	4594	3938	3445	3063						
5	4 x 1/4	9000	7200	6000	5143	4500	4000	3600					
5-1/2	4-1/2 x 1/4	11391	9113	7594	6509	5695	5063	4556	4142	3797			
6	5 x 1/4	14063	11250	9375	8036	7031	6250	5625	5114	4688			
6-1/2	5-1/2 x 1/4	17016	13613	11344	9723	8508	7563	6806	6188	5672	4862		
7	6 x 1/4	20250	16200	13500	11571	10125	9000	8100	7364	6750	5786	5063	
8	7 x 1/4	27563	22050	18375	15750	13781	12250	11025	10023	9188	7875	6891	

Loads given are theoretical and based on a unit stress of 27,000 psi.

Wheels n' Heels® InVent® 64-7-WH-63 3/16" Grade 50 Carbon Steel

Bicycle Friendly

Banding Optional ▶

This grating meets ANSI/NAAMM MBG - 532, ADA & High heel spacing & AASHTO H20/H15 standards.

A OnGrip® Spray Traction Surface is recommended to meet ADA guidelines.

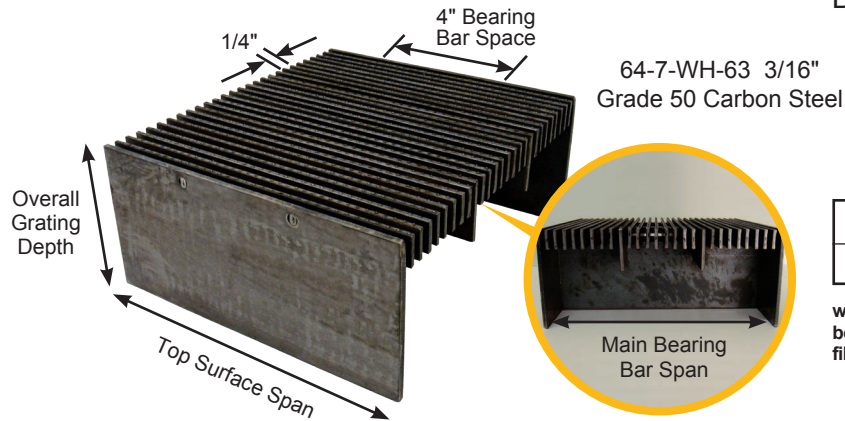

64-7-WH-63 3/16"
Grade 50 Carbon Steel

% Open Area*
52%

with 1/4" opening between bearing or filler bars.

Main bearing bars are concealed below the swaged panel.

Size, Overall Grating Depth Inches	Main Bearing Bar Inches Grade 50	Weight Lbs./ Sq. Ft.	Section Properties		Top Surface Bar Size, Inches	Maximum Safe ClearSpan , Inches- Partially Distributed Load				Maximum Manufactured Span Top Surface Bars Inches
			Sx, in ³ Ft. Width	Ix, in ⁴ Ft. Width		Lift Truck Capacity			AASHTO H15/H20	
						1 Ton	3 Ton	5 Ton		
2-1/2	1-1/2 x 1/4	22.85	0.281	0.211	1 x 3/16	11	8	9	11	288
3	2 x 1/4	24.13	0.500	0.500	1 x 3/16	18	11	12	14	288
3-1/2	2-1/2 x 1/4	25.41	0.781	0.977	1 x 3/16	27	16	15	18	288
4	3 x 1/4	26.69	1.125	1.688	1 x 3/16	37	21	20	22	288
4-1/2	3-1/2 x 1/4	27.97	1.531	2.680	1 x 3/16	50	27	25	28	288
5	4 x 1/4	29.24	2.000	4.000	1 x 3/16	63 *	34	31	34	288
5-1/2	4-1/2 x 1/4	30.52	2.531	5.695	1 x 3/16	76 *	43	38	41	288
6	5 x 1/4	31.80	3.125	7.813	1 x 3/16	89 *	50 *	45	48	288
6-1/2	5-1/2 x 1/4	33.08	3.781	10.398	1 x 3/16	96 *	58 *	53	56	288
7	6 x 1/4	34.36	4.500	13.500	1 x 3/16	96 *	66 *	63	65	288
8	7 x 1/4	36.91	6.125	21.438	1 x 3/16	96 *	83 *	83	84	288

*Span limited based on L / 400 max deflection or 96" max span.

Size Inches	Main Bearing Bar Inches	Maximum Safe Concentrated Load, Lbs./Ft. Width - at ClearSpan										
		2'- 0"	2'- 6"	3'- 0"	3'- 6"	4'- 0"	4'- 6"	5'- 0"	5'- 6"	6'- 0"	7'- 0"	8'- 0"
2-1/2	1-1/2 x 1/4	1266										
3	2 x 1/4	2250	1800									
3-1/2	2-1/2 x 1/4	3516	2813	2344								
4	3 x 1/4	5063	4050	3375	2893	2531						
4-1/2	3-1/2 x 1/4	6891	5513	4594	3938	3445	3063					
5	4 x 1/4	9000	7200	6000	5143	4500	4000	3600				
5-1/2	4-1/2 x 1/4	11391	9113	7594	6509	5695	5063	4556	4142	3797		
6	5 x 1/4	14063	11250	9375	8036	7031	6250	5625	5114	4688		
6-1/2	5-1/2 x 1/4	17016	13613	11344	9723	8508	7563	6806	6188	5672	4862	
7	6 x 1/4	20250	16200	13500	11571	10125	9000	8100	7364	6750	5786	5063
8	7 x 1/4	27563	22050	18375	15750	13781	12250	11025	10023	9188	7875	6891

Loads given are theoretical and based on a unit stress of 27,000 psi.

Wheels n' Heels® InVent® 64-10-WH-60 1/8" Grade 50 Carbon Steel

Bicycle Friendly

Banding Optional ▶

This grating meets ANSI/NAAMM MBG - 532, ADA spacing & AASHTO H20/H15 standards.

A OnGrip® Spray Traction Surface is recommended to meet ADA guidelines.

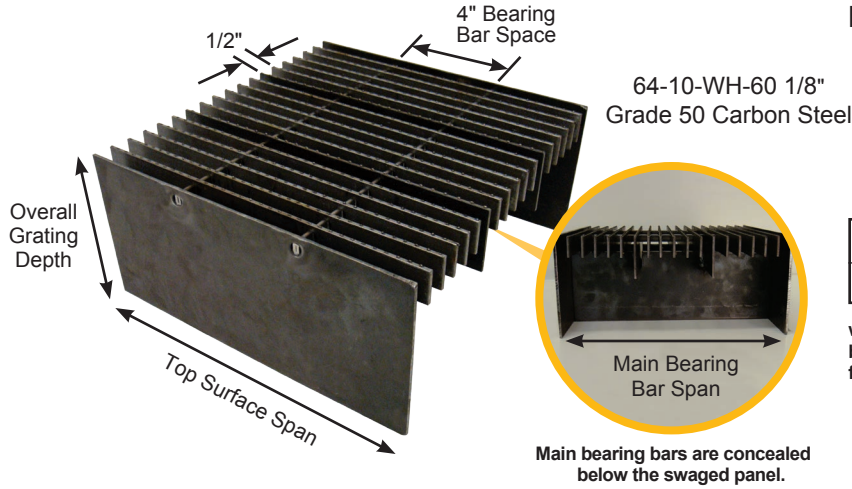

64-10-WH-60 1/8"
Grade 50 Carbon Steel

% Open Area*
76%

with 1/2" opening between bearing or filler bars.

Size, Overall Grating Depth Inches	Main Bearing Bar Inches Grade 50	Weight Lbs./ Sq. Ft.	Section Properties		Top Surface Bar Size, Inches	Maximum Safe ClearSpan, Inches- Partially Distributed Load				Maximum Manufactured Span Top Surface Bars Inches
			Sx, in ³ Ft. Width	Ix, in ⁴ Ft. Width		Lift Truck Capacity			AASHTO H15/H20	
						1 Ton	3 Ton	5 Ton		
2-1/2	1-1/2 x 1/4	13.21	0.281	0.211	1 x 1/8	11	8	9	11	288
3	2 x 1/4	14.49	0.500	0.500	1 x 1/8	18	11	12	14	288
3-1/2	2-1/2 x 1/4	15.77	0.781	0.977	1 x 1/8	27	16	15	18	288
4	3 x 1/4	17.05	1.125	1.688	1 x 1/8	37	21	20	22	288
4-1/2	3-1/2 x 1/4	18.33	1.531	2.680	1 x 1/8	50	27	25	28	288
5	4 x 1/4	19.60	2.000	4.000	1 x 1/8	63 *	34	31	34	288
5-1/2	4-1/2 x 1/4	20.88	2.531	5.695	1 x 1/8	76 *	43	38	41	288
6	5 x 1/4	22.16	3.125	7.813	1 x 1/8	89 *	50 *	45	48	288
6-1/2	5-1/2 x 1/4	23.44	3.781	10.398	1 x 1/8	96 *	58 *	53	56	288
7	6 x 1/4	24.72	4.500	13.500	1 x 1/8	96 *	66 *	63	65	288
8	7 x 1/4	27.27	6.125	21.438	1 x 1/8	96 *	83 *	83	84	288

*Span limited based on L / 400 max deflection or 96" max span.

Size Inches	Main Bearing Bar Inches	Maximum Safe Concentrated Load, Lbs./Ft. Width - at ClearSpan											
		2'- 0"	2'- 6"	3'- 0"	3'- 6"	4'- 0"	4'- 6"	5'- 0"	5'- 6"	6'- 0"	7'- 0"	8'- 0"	
2-1/2	1-1/2 x 1/4	1266											
3	2 x 1/4	2250	1800										
3-1/2	2-1/2 x 1/4	3516	2813	2344									
4	3 x 1/4	5063	4050	3375	2893	2531							
4-1/2	3-1/2 x 1/4	6891	5513	4594	3938	3445	3063						
5	4 x 1/4	9000	7200	6000	5143	4500	4000	3600					
5-1/2	4-1/2 x 1/4	11391	9113	7594	6509	5695	5063	4556	4142	3797			
6	5 x 1/4	14063	11250	9375	8036	7031	6250	5625	5114	4688			
6-1/2	5-1/2 x 1/4	17016	13613	11344	9723	8508	7563	6806	6188	5672	4862		
7	6 x 1/4	20250	16200	13500	11571	10125	9000	8100	7364	6750	5786	5063	
8	7 x 1/4	27563	22050	18375	15750	13781	12250	11025	10023	9188	7875	6891	

Loads given are theoretical and based on a unit stress of 27,000 psi.

Wheels n' Heels® InVent® 64-11-WH-66 3/16" Grade 50 Carbon Steel

Bicycle Friendly

Banding Optional ▶

This grating meets ANSI/NAAMM MBG - 532, ADA spacing & AASHTO H20/H15 standards.

A OnGrip® Spray Traction Surface is recommended to meet ADA guidelines.

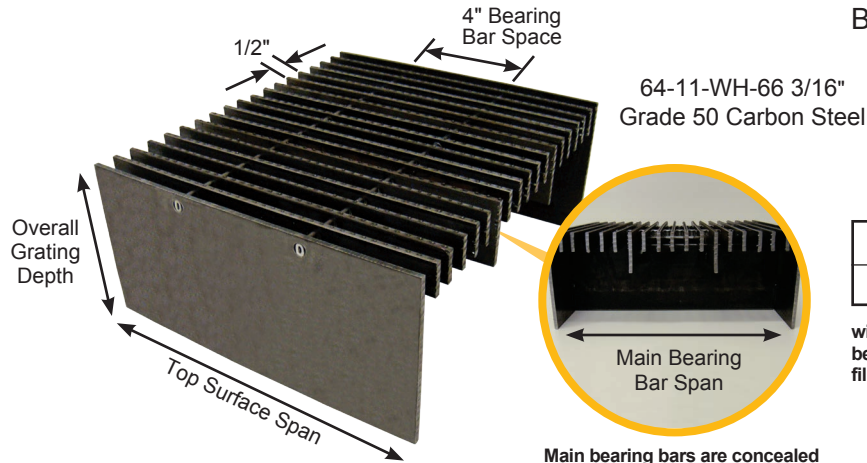

% Open Area*
68%

with 1/2" opening between bearing or filler bars.

Size, Overall Grating Depth Inches	Main Bearing Bar Inches Grade 50	Weight Lbs./ Sq. Ft.	Section Properties		Top Surface Bar Size, Inches	Maximum Safe ClearSpan , Inches- Partially Distributed Load				Maximum Manufactured Span Top Surface Bars Inches
			Sx, in ³ Ft. Width	Ix, in ⁴ Ft. Width		Lift Truck Capacity			AASHTO H15/H20	
						1 Ton	3 Ton	5 Ton		
2-1/2	1-1/2 x 1/4	16.44	0.281	0.211	1 x 3/16	11	8	9	11	288
3	2 x 1/4	17.71	0.500	0.500	1 x 3/16	18	11	12	14	288
3-1/2	2-1/2 x 1/4	18.99	0.781	0.977	1 x 3/16	27	16	15	18	288
4	3 x 1/4	20.27	1.125	1.688	1 x 3/16	37	21	20	22	288
4-1/2	3-1/2 x 1/4	21.55	1.531	2.680	1 x 3/16	50	27	25	28	288
5	4 x 1/4	22.83	2.000	4.000	1 x 3/16	63 *	34	31	34	288
5-1/2	4-1/2 x 1/4	24.10	2.531	5.695	1 x 3/16	76 *	43	38	41	288
6	5 x 1/4	25.38	3.125	7.813	1 x 3/16	89 *	50 *	45	48	288
6-1/2	5-1/2 x 1/4	26.66	3.781	10.398	1 x 3/16	96 *	58 *	53	56	288
7	6 x 1/4	27.94	4.500	13.500	1 x 3/16	96 *	66 *	63	65	288
8	7 x 1/4	30.49	6.125	21.438	1 x 3/16	96 *	83 *	83	84	288

*Span limited based on L / 400 max deflection or 96" max span.

Size Inches	Main Bearing Bar Inches	Maximum Safe Concentrated Load, Lbs./Ft. Width - at ClearSpan											
		2'- 0"	2'- 6"	3'- 0"	3'- 6"	4'- 0"	4'- 6"	5'- 0"	5'- 6"	6'- 0"	7'- 0"	8'- 0"	
2-1/2	1-1/2 x 1/4	1266											
3	2 x 1/4	2250	1800										
3-1/2	2-1/2 x 1/4	3516	2813	2344									
4	3 x 1/4	5063	4050	3375	2893	2531							
4-1/2	3-1/2 x 1/4	6891	5513	4594	3938	3445	3063						
5	4 x 1/4	9000	7200	6000	5143	4500	4000	3600					
5-1/2	4-1/2 x 1/4	11391	9113	7594	6509	5695	5063	4556	4142	3797			
6	5 x 1/4	14063	11250	9375	8036	7031	6250	5625	5114	4688			
6-1/2	5-1/2 x 1/4	17016	13613	11344	9723	8508	7563	6806	6188	5672	4862		
7	6 x 1/4	20250	16200	13500	11571	10125	9000	8100	7364	6750	5786	5063	
8	7 x 1/4	27563	22050	18375	15750	13781	12250	11025	10023	9188	7875	6891	

Loads given are theoretical and based on a unit stress of 27,000 psi.

HEAVY DUTY RIVETED STEEL



R SERIES

Heavy duty riveted grating is the oldest style of industrial grating, but still the choice of many engineers due to its ruggedness, reliability and durability. This grating is composed of straight bearing bars and bent connecting bars which are joined at their contact points by rivets. Since the connecting bars extend continuously between bearing bars along the grating spans, they not only serve to join the bearing bars together, but also contribute to the load carrying capability and lateral stability of the grating panels. This added dimension makes heavy duty riveted grating an ideal choice where high strength and stiffness are required. These products are ideal for vehicle bridge decks. Slip resistant surfaces are available.

Serrated surface also available.
*** Other bridge deck configurations are available.**
Please call for details.

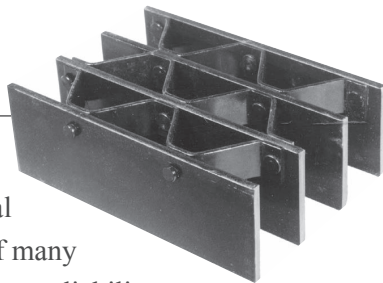

GRATING PROFILES AVAILABLE...

R Series Heavy Duty Riveted Steel

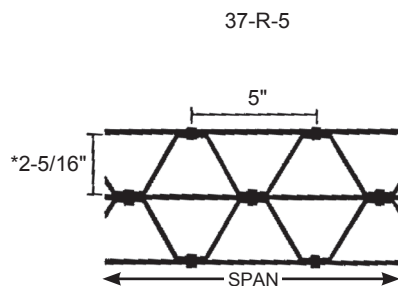

***Note:** That riveted grating marking indicates space between bearing bars.

37 SPACE

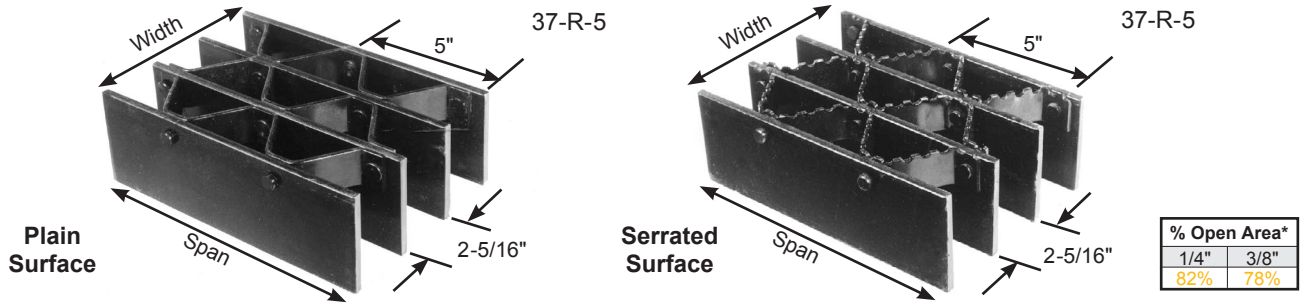

Bar Size, Inches	Wt.* Lbs. Sq. Ft.	Section Properties		Cross Bar Size, Inches	Maximum Safe ClearSpan, Inches- Partially Distributed Load			
		Sx*, in ³ Ft. Width	Ix*, in ⁴ Ft. Width		1 Ton	3 Ton	5 Ton	H15/H20
2 x 1/4	14.63	0.991	1.080	1-1/2 x 3/16	19	12	13	16
2 x 3/8	17.91	1.319	1.409	1-1/2 x 3/16	25	16	16	19
2-1/4 x 1/4	15.68	1.185	1.482	1-1/2 x 3/16	22	14	15	17
2-1/4 x 3/8	19.41	1.606	1.957	1-1/2 x 3/16	30	18	18	21
2-1/2 x 1/4	17.02	1.422	1.999	1-1/2 x 3/16	26	16	17	20
2-1/2 x 3/8	20.84	1.946	2.657	1-1/2 x 3/16	37	22	21	24
3 x 1/4	19.27	2.006	3.420	1-1/2 x 3/16	37	22	21	25
3 x 3/8	23.96	2.769	4.568	1-1/2 x 3/16	51	29	28	31
3-1/2 x 1/4	21.52	2.723	5.427	1-1/2 x 3/16	49	28	27	31
3-1/2 x 3/8	27.09	3.764	7.252	1-1/2 x 3/16	65	38	36	40
4 x 1/4	23.78	3.560	8.097	1-1/2 x 3/16	63	36	33	38
4 x 3/8	30.21	4.923	10.818	1-1/2 x 3/16	74	49	45	50
4-1/2 x 1/4	26.03	4.513	11.508	1-1/2 x 3/16	74	44	41	46
4-1/2 x 3/8	33.34	6.238	15.372	1-1/2 x 3/16	83	61	55	60
5 x 1/4	28.28	5.577	15.735	1-1/2 x 3/16	83	54	49	54
5 x 3/8	36.46	7.705	21.021	1-1/2 x 3/16	92	74	67	72

*Based on approximately 4.5 bars/ft of grating width. Bearing bars 2-5/16" face-to-face.

Bar Size, Inches	Maximum Safe Concentrated Load*, Lbs. - ClearSpan													
	1'- 0"	1'- 6"	2'- 0"	2'- 6"	3'- 0"	3'- 6"	4'- 0"	4'- 6"	5'- 0"	5'- 6"	6'- 0"	6'- 6"	7'- 0"	8'- 0"
2 x 1/4	6607	4404	3303	2643	2202	1888	1652	1468	1321	1201	1101	1016	944	826
2 x 3/8	8792	5862	4396	3517	2931	2512	2198	1954	1758	1599	1465	1353	1256	1099
2-1/4 x 1/4	7903	5268	3951	3161	2634	2258	1976	1756	1581	1437	1317	1216	1129	988
2-1/4 x 3/8	10706	7137	5353	4282	3569	3059	2677	2379	2141	1947	1784	1647	1529	1338
2-1/2 x 1/4	9481	6321	4741	3793	3160	2709	2370	2107	1896	1724	1580	1459	1354	1185
2-1/2 x 3/8	12974	8649	6487	5190	4325	3707	3244	2883	2595	2359	2162	1996	1853	1622
3 x 1/4	13373	8916	6687	5349	4458	3821	3343	2972	2675	2432	2229	2057	1910	1672
3 x 3/8	18457	12304	9228	7383	6152	5273	4614	4101	3691	3356	3076	2839	2637	2307
3-1/2 x 1/4	18151	12101	9076	7261	6050	5186	4538	4034	3630	3300	3025	2793	2593	2269
3-1/2 x 3/8	25096	16731	12548	10038	8365	7170	6274	5577	5019	4563	4183	3861	3585	3137
4 x 1/4	23735	15823	11867	9494	7912	6781	5934	5274	4747	4315	3956	3651	3391	2967
4 x 3/8	32821	21880	16410	13128	10940	9377	8205	7293	6564	5967	5470	5049	4689	4103
4-1/2 x 1/4	30087	20058	15044	12035	10029	8596	7522	6686	6017	5470	5015	4629	4298	3761
4-1/2 x 3/8	41587	27724	20793	16635	13862	11882	10397	9241	8317	7561	6931	6398	5941	5198
5 x 1/4	37181	24787	18590	14872	12394	10623	9295	8262	7436	6760	6197	5720	5312	4648
5 x 3/8	51366	34244	25683	20546	17122	14676	12842	11415	10273	9339	8561	7902	7338	6421

*Based on Bearing bars/ Ft of Width = No. of Connecting bars/ Ft of Width = 4.683 for b = 1/4" & Based on Bearing bars/ Ft of Width = No. of Connecting bars/ Ft of Width = 4.465 for b = 3/8" Allowable Fiber Stress = 20,000 psi

Panel Width Chart (in.) - 37-R-5		Dimensions Are Out-to-Out of Bearing Bars**													
No. of Bars	2	3	4	5	6	7	8	9	10	11	12	13	14	15	16
1/4" Bars	2-13/16	5-3/8	7-15/16	10-1/2	13-1/16	15-5/8	18-3/16	20-3/4	23-5/16	25-7/8	28-7/16	31	33-9/16	36-1/8	38-11/16
3/8" Bars	3-1/16	5-3/4	8-7/16	11-1/8	13-13/16	16-1/2	19-3/16	21-7/8	24-9/16	27-1/4	29-15/16	32-5/8	35-5/16	38	40-11/16

**Add 3/8" for rivet heads.

ANCHORING DEVICES

Saddle Clip

A special bent-clip type fastener for removable bar grating panels, available in aluminum, stainless steel and galvanized steel.

Note: Cross bars may need to be snipped in the field to facilitate placement of saddle clips.

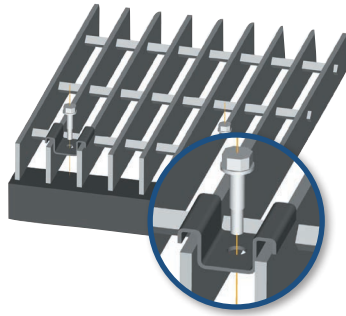

Lug

A plank lug inserted then tack welded between flanges, can serve as an ideal anchor block for plank grating.

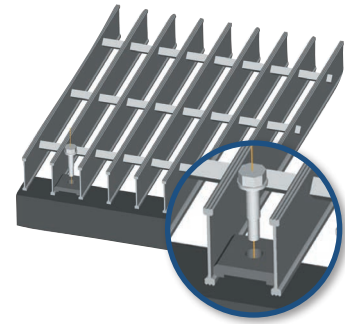

Channel Frame

A special C-channel frame fastener system used in conjunction with welded anchor blocks between bearing bars. The fabricated frame is held in place by TEK screws that are attached to the anchor blocks. Recommended spacing is between 12" and 16" O.C."

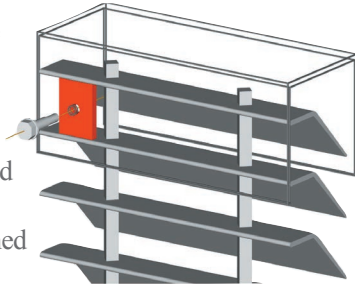

Z-Clip

The most versatile clip anchor available is the Z-Clip. They are especially helpful in holding down riveted grating. Z-Clips are manufactured from stainless steel and are available in 1" (1" & 1-1/4" grating), 1-1/2" (1-1/2" & 1-3/4" grating), and 2" (2", 2-1/4" & 2-1/2" grating) with a pre-punched hole to accept a 1/4" bolt or TEK screw.

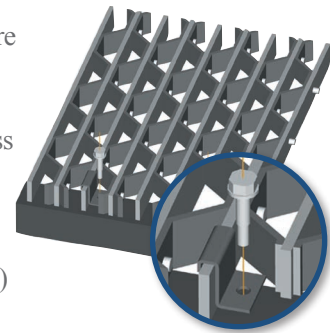

Grating Clamp

A special friction fastener available in stainless steel and galvanized steel used in conjunction with bar grating and embedded grating frames.

Note: Cross bars may need to be snipped in the field to facilitate placement of grating clamps.

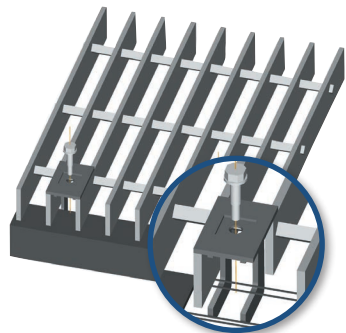

Countersunk Land

For close-mesh aluminum grating (7/16") bearing bar centers, a countersunk land may be drilled by the grating manufacturer for use with a 1/4" dia. TEK screw.

Note: Available for aluminum grating and steel.

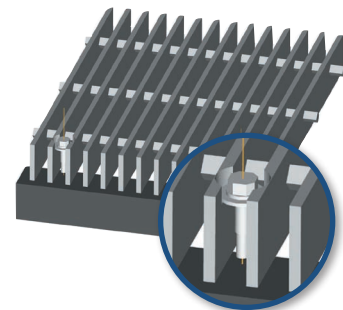

Anchor Block

Anchor blocks of 1/4" or 3/16" thick aluminum or steel may be shop welded by the grating manufacturer and used to fasten permanent or removable grating panels. Anchor blocks are recessed thus offering a trip-free surface.

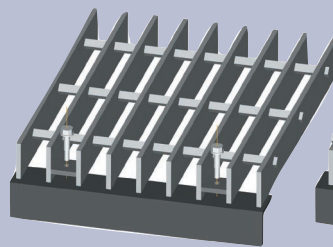

19-SG-4

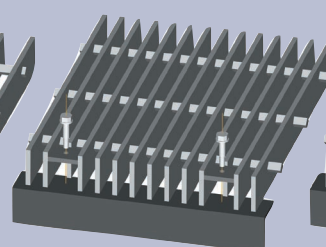

11-SG-4

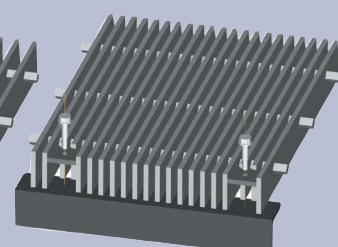

7-SG-4

Note: For ADA compliant spacings, the lug will typically be installed at the top. Tack welding of grating in the field (by others) is also a positive method for anchoring all permanently installed grating.

STANDARD PRACTICES

The following information has been excerpted from the NAAMM Metal Bar Grating Manual and represents those practices which are generally accepted to be standard in the metal bar grating industry.

Quotations

Quotations shall be offered on the basis of unit price per square foot (in rectangular sections) and per tread. Plans submitted for bidding shall be fully dimensioned and shall provide the complete product description, including bar spacing, span direction, cutout locations, anchorage devices, and finish required.

Extras

A partial list of those items not included in unit price quotations, and which shall be treated as unit price extras, is as follows: straight and circular cutting and banding, toe plates, support plates or angles, hinges, lift handles, locking devices, anchors, hole drilling or punching, grinding of welds, sandblasting, deburring and special bundling.

Drawings & Specifications

The Buyer is expected to furnish a set of construction drawings and specifications of current issue showing the layout of supports and floor openings correctly dimensioned, together with the sizes and types of grating and treads required. The Seller shall submit to the Buyer three (3) prints or one reproducible paper copy of detailed drawings in outline form for the latter's approval or desired changes. The Buyer shall return one copy marked with approval or desired changes. Should changes be required which involve work not called for in the original plans and specifications, the Seller shall have the right to charge extra for the engineering work required to make such changes. After all necessary corrections and/or changes are made, the drawings shall be resubmitted to the Buyer for his final approval. The Seller shall not proceed with any shop work until drawings are finally approved.

Installation Drawings

If requested, the Seller shall furnish to the Buyer, a maximum of four sets of prints or one reproducible paper copy of all installation drawings.

Quantity Measurements

Quantity measurements for gratings ordered to specific dimensions without drawings, shall be based on span times width of each panel, with no deduction made for cutouts. Final calculated grating quantities supplied from drawings shall be on the basis of gross area measured center-to-center of supports, or back-to-back of supporting angles or channels, or overall dimensions of grating, whichever is larger, with no deduction for clearances. Measurement of cuts shall be on the basis of a minimum of one lineal foot per cut panel. Any cut in excess of one lineal foot shall be measured to the next higher lineal foot. Measurement of banding, toe plates and nosings shall be on the same basis as that of cuts.

Changes in Scope

If at any time during the course of the work, the Buyer orders changes made which require materials and/or labor not called for in the original bidding plans, the cost of making such changes shall be paid by the Buyer at a price to be agreed upon.

Field Work

The Seller shall not be responsible for taking actual measurements of construction work in the field, nor for erection or installation of the grating.

Backcharges

Upon discovery of unsatisfactory material, the Buyer shall immediately notify the Seller, who will initiate an investigation into the complaint. The Seller shall be given the opportunity to inspect the material **PRIOR TO ANY CORRECTIVE WORK BEING DONE**. The Seller is responsible for providing grating in accordance with approved drawings and specifications. The Seller is not responsible for field changes, drawing changes not received and approved by Seller prior to grating fabrication, improper fabrication and/or erection of supporting members. If the investigation and inspection confirm errors in grating fabrication, the Seller agrees to repair and/or replace defective material at no additional charge to Buyer.

Claims

All claims are handled independently of all initial orders or invoices.

SPECIFICATION INFORMATION

OGi is a member in good standing with the National Association of Architectural Metal Manufacturers.

All aluminum and steel grating manufactured and fabricated by Ohio Gratings is done so in accordance with the NAAMM Metal Bar Grating Manual, current edition, which is an approved standard of the American National Standards Institute and designated as ANSI/

NAAMM MBG 531 (steel, stainless steel, and aluminum grating and stair treads) and ANSI/NAAMM MBG 532 (structural carbon steel and stainless steel).

The following table outlines the material, Federal, Military and finishing specifications routinely used by the grating industry. In the absence of customer furnished specifications, the following will apply:

SPECIFICATIONS				
PRODUCT	MATERIAL	FEDERAL	MILITARY	FINISH
Aluminum Flush Top, Aluminum Rectangular Bar, Aluminum I-Bar, Lite Bar, Aluminum Dove Tail, Aluminum Riveted	1. Alloy 6063-T6 per ASTM B-221 and QQ -A-200/9. 2. Alloy 6061-T6 per ASTM B-221 and QQ -A-200/8 (by inquiry).	ANSI /NAAMM MBG 531	MIL-G-18014 (Ships)	1. Mill Finish 2. Clear Anodized AA-A31 (30 min.) or AA-A41 (60 min.) (by inquiry). 3. Other (by inquiry).
Aluminum Plank, Aluminum Grating Frames	1. Alloy 6063-T6 per ASTM B-221 and QQ -A-200/9.		MIL-G-18015 (Ships)	1. Mill Finish 2. Other (by inquiry).
Heavy Duty Welded Steel, Heavy Duty Riveted Steel	1. Grade 36 (1/4", 5/16", 3/8", 1/2" carbon steel). 2. Other (by inquiry).	AASHTO (American Association of State Highway & Transportation Officials) Standard Specification For Highway Bridges ANSI/NAAMM MBG 532		1. One coat manufacturer's standard black paint. This is not a permanent finish system, but is intended to protect the grating in transit only because it will chip. 2. Galvanizing per ASTM A-123/A-385.
Light Duty Welded Carbon Steel, Light Duty Dove Tail Carbon Steel, Light Duty Swaged Carbon Steel, Light Duty Swaged Stainless Steel, Light Duty Riveted Carbon Steel, Light Duty Welded Stainless Steel	1. ASTM A-1011 (1/8", 3/16", 1/4" carbon steel). 2. Grade 36 (1/4" carbon steel) by inquiry. 3. Type 304 per ASTM A-666 (1/8" and 3/16" stainless steel). 4. Other (by inquiry).	ANSI /NAAMM MBG 531	MIL-G-18014 (Ships)	1. One coat manufacturer's standard black paint. This is not a permanent finish system, but is intended to protect the grating in transit only because it will chip. 2. Galvanizing per ASTM A-123/A-385.
Light Duty Carbon Steel All Aluminum Products	1. Alloy 6063-T6 per ASTM B-221 and QQ -A-200/9.	ANSI /NAAMM MBG 531	NA	1. TGIC Polyester Systems, a permanent durable finish that resists impact, humidity and salt spray which increases material longevity.

*Effective March 10, 1989, the Naval Facilities Engineering Command adopted the NAAMM Metal Bar Grating Manual for Department of Defense use, replacing Federal Spec RR-G-661 as the specification for carbon steel and aluminum metal bar grating flooring, except for naval vessels.

A Word About Finishing Grating

Since the aluminum oxide coating of aluminum bar is relatively inert chemically, and is self-repairing when damaged in the presence of oxygen, aluminum bar

grating possesses a high degree of corrosion resistance in the mill finished condition, and is typically specified without additional coatings or treatment.

ADA GUIDELINES

ADA Accessibility Guidelines

On July 26, 1991 the Architectural and Transportation Barriers Compliance Board (Access Board) published the Americans with Disabilities Act Accessibility Guidelines (ADAAG). The ADA establishes accessibility requirements for new construction and alterations of State and local government facilities, and places of public accommodation and commercial facilities. As updated in the November 16, 1999 ADAAG Notice of Proposed Rule making, section 302.3 states that “openings in floor or ground surfaces shall allow passage of a sphere not more than 1/2 inch (13 mm) diameter. Elongated openings shall be placed so that the long dimension is perpendicular to the dominant direction of travel.”

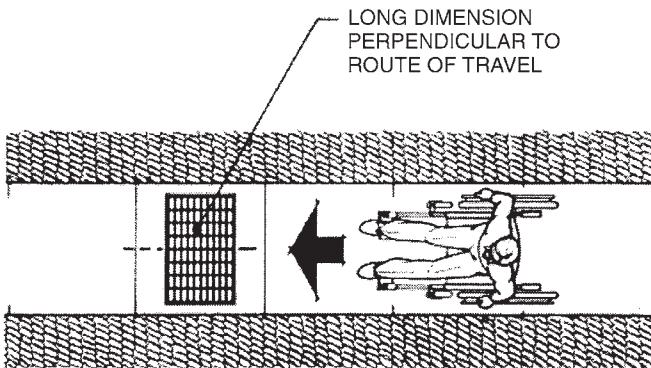

Ohio Gratings manufactures Aluminum, Light Duty Carbon and Stainless Steel, and Heavy Duty Carbon Steel grating products which conform with the spacing requirements of the ADA Accessibility Guidelines for Buildings and Facilities. The specification and use of this family of **GRATER AccESS®** products will ensure that your project is both pedestrian friendly and vehicle safe. Since these Accessibility Guidelines are subject to change, please contact the factory for up-to-date information regarding the use of grating in ADA applications.

Note: Bar grating has historically been an industrial foot walk product, intended for use in catwalks, platforms, stairways, and roadways (Heavy Duty only), and is designed to be installed in a fastened condition. This grating is standardly subject to manufacturing and fabrication tolerances as dictated by the ANSI/NAAMM Metal Bar Grating Manual. While these tolerances and the various finishes available are suitable for most industrial applications, they may not be appropriate for some commercial or architectural uses. Please contact the factory for further specification assistance.



ADA Note: As of the publication date of this catalog, Ohio Gratings' products having a 1/2" maximum opening conform with the Americans with Disabilities Act Accessibility Guidelines (ADAAG), issued in July 1991, and the ADAAG Notice of Proposed Rule making issued on November 16, 1999, for grating when installed with the elongated opening perpendicular to the dominant direction of travel.

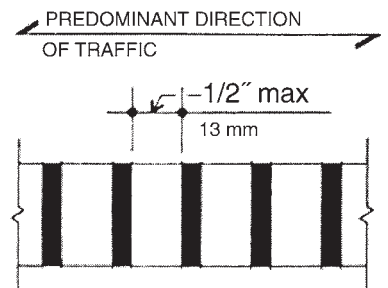

NOMENCLATURE & VOCABULARY

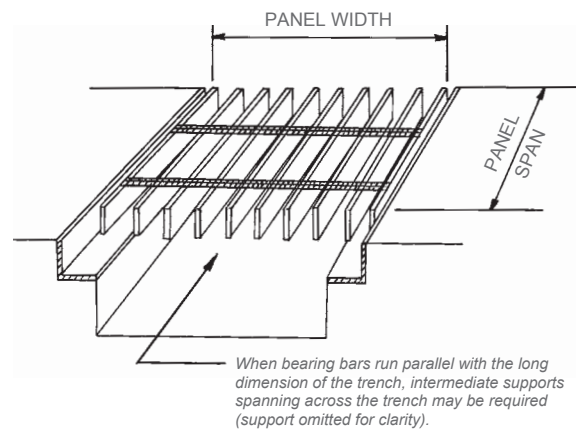
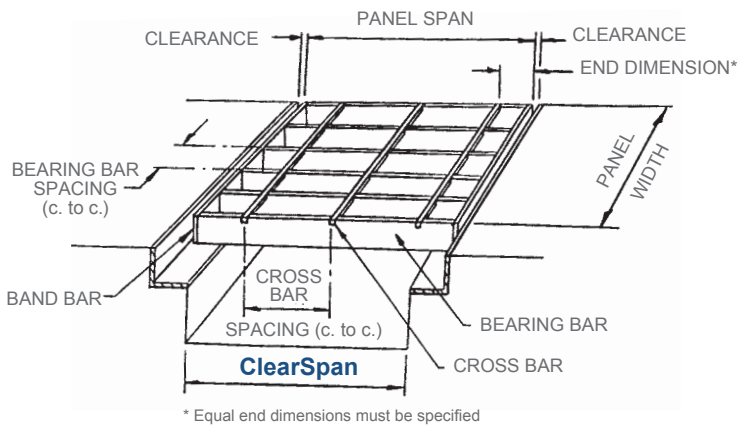

Methods of name identification used in this catalog

This catalog uses a form of the NAAMM alpha-numeric designation for bar spacing and manufacturing identification. The first number signifies center-to-center bearing bar spacing in 1/16ths of an inch*. A letter designates method of manufacture. The last number details center-to-center cross bar spacing in whole inches (usually 4" or 2"), or rivet spacing (usually 3-1/2", 5" or 7").

Methods of manufacturing and their letter designations used in this catalog:

SG- Swaged Rectangular Bar	W- Welded Steel
SGF- Swaged Flush	DT- Dove Tail
SGLI- Swaged I-Bar	ADT- Dove Tail (Aluminum)
SGLi- Swaged Lite Bar	SGCS- Swaged Carbon Steel
R- Riveted (Steel)	SGSS- Swaged Stainless Steel
AR- Riveted Aluminum	WH- Wheels n' Heels®
LG- Louver	PL- MBG PressLock

For Example:

19-W-4	Bearing Bars 19/16" (or 1-3/16") c.c. – Welded Steel Construction – Cross Bars 4" c.c.
15-SGLI-2	Bearing Bars 15/16" c.c. – Swaged I-Bar – Cross Bars 2" c.c.

Other Bearing Bar spacings commonly used throughout the industry are designated this way:

38-W-4 (or 2)	Bearing Bars 38/16" c.c.(2-3/8" c.c.)
30-W-4 (or 2)	Bearing Bars 30/16" c.c.(1-7/8" c.c.)
22-W-4 (or 2)	Bearing Bars 22/16" c.c.(1-3/8" c.c.)
11-SG-4 (or 2)	Bearing Bars 11/16" c.c.
7-SG-4 (or 2)	Bearing Bars 7/16" c.c.
18-R-7 (or 3-1/2)	Bearing Bars 18/16" c.c. face-to-face (1-1/8")*
37-R-5	Bearing Bars 37/16" c.c. face-to-face (2-5/16")*
12-R-7 (or 3-1/2)	Bearing Bars 12/16" c.c. face-to-face (3/4")*

PRESSURE LOCKED GRATING

Pressure Locking

The most common method of manufacturing aluminum bar grating is through a process known as pressure locking. Pressure locked grating as defined by the NAAMM Metal Bar Grating Manual is grating in which “bearing bars are locked in position by cross bar deformation instead of riveting or welding.” Ohio Gratings manufactures both traditional, dove tail pressure locked grating, and swaged grating. Both manufacturing processes are used to manufacture, not only aluminum grating, but also carbon steel grating (see pages 43). Additionally, the swaging process is used to produce stainless steel grating (see page 61). Each method of manufacture is further described below.

Aluminum Flush Top Grating

Aluminum Flush Top grating from Ohio Gratings combines the sure lock reliability of swage-locked grating with the cosmetic appeal and added walking surface of traditional pressure locked grating. Best of all, by taking advantage of the swage-lock manufacturing process, Aluminum Flush Top grating offers a cost savings over traditional pressure locked grating while at the same time allowing banding to be an option rather than a requirement. Field cutting is also possible.

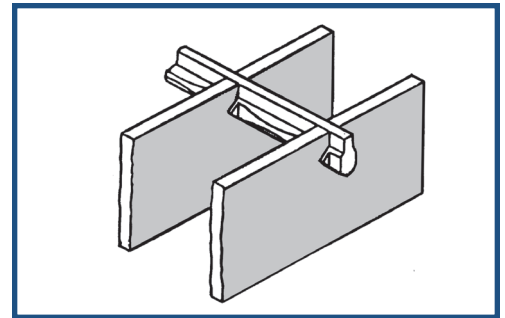

Aluminum Rectangular/I-Bar Grating

These two grating designs utilize a process by which 1/4" or 5/16" square cross bars are assembled through punched, diamond shaped holes in the bearing bars, and then secured by swaging to prevent turning, twisting, or loosening. Available with either rectangular or I-shaped bearing bar sections, this manufacturing process offers:

1. The economy of cutting individual pieces from panels.
2. Enables field alteration of grating panels.
3. Allows banding as an option rather than as a requirement.

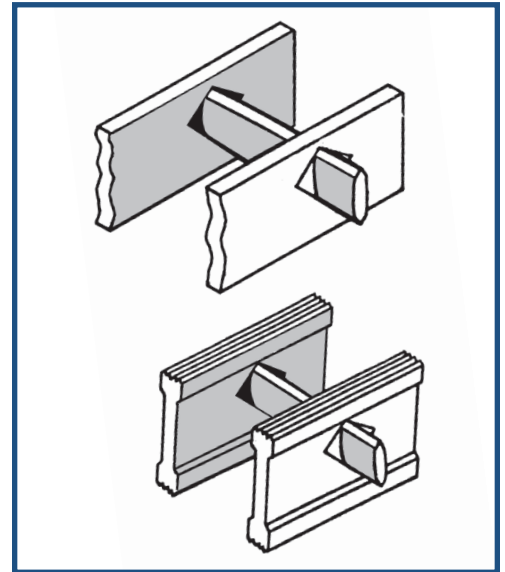

Dove Tail Pressure Locked Grating

This first generation pressure locked design involves pressing the cross bars into the main bars under hydraulic pressure, forcing 1/16" of cross bar material laterally into “dove tail” slots in the main bars. Each piece is then generally end banded to provide panel stability, and outside bearing bars and cross bars are usually tack welded to ensure integrity. Pieces may be made individually to size, or may be shop cut from panels. Field alteration of this style of grating is typically more difficult than field fabrication of swaged grating, and is generally discouraged.

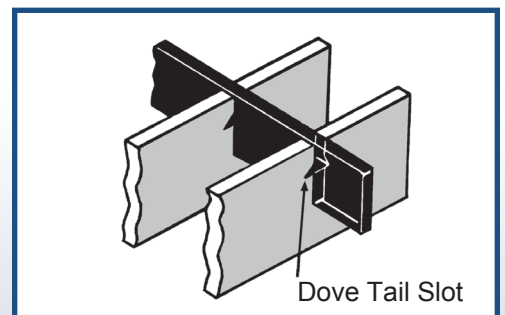

CUSTOM FABRICATION

All types of fabrication typically associated with the grating industry are performed by experienced and expert craftsmen at Ohio Gratings. Services available include straight and circular cutting and banding, fabrication of radially cut grating panels, toe plate attachment, grating with checker plate, heavy duty grating with cross bars top and bottom, serrated heavy duty bearing bars and cross bars, egg-crate construction, vault grating, grating with hinges and locks, and heavy duty grating with spacer bars to form an extremely close mesh (see Wheels n' Heels® Heavy Duty Steel Grating).

Drawings & Templates

The majority of fabrication performed by Ohio Gratings is done in accordance with grating drawings prepared by the Engineering Department. These grating erection drawings are generally produced from the structural drawings, or grating outline drawings, as supplied by the customer.

Each grating panel is tagged with a mark number which corresponds to a mark number on the drawing. This marking system allows grating panels to be identified during the fabrication process, and, when used in conjunction with the grating drawing, facilitates the correct placement of grating panels during erection.

While some grating companies work from floor layouts, Ohio Gratings has chosen to employ personnel thoroughly versed in the trigonometry of grating design, and shop employees who are experts at blueprint reading. This combination has been found to be the most efficient approach to drawing preparation, customer drawing approval, and shop fabrication.

Occasionally, extremely intricate grating areas require that fabrication be accomplished from a template used to supplement the grating drawing. Templates supplied by the customer are usually made from cardboard or plastic. In addition to grating configuration, templates must indicate top and bottom sides, and whether or not they represent the size of the opening or the size of the grating. Grating can be fabricated from templates for a nominal charge, over and above the standard fabrication charge.

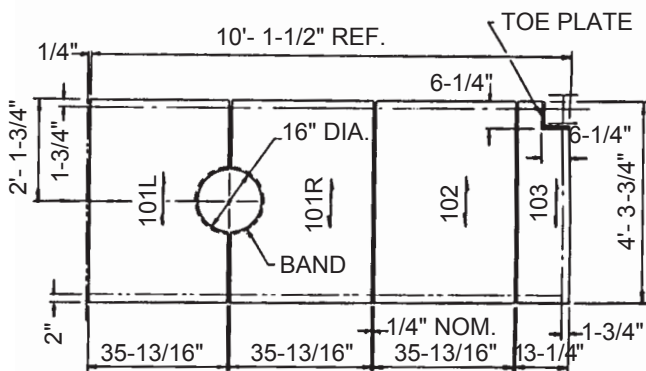
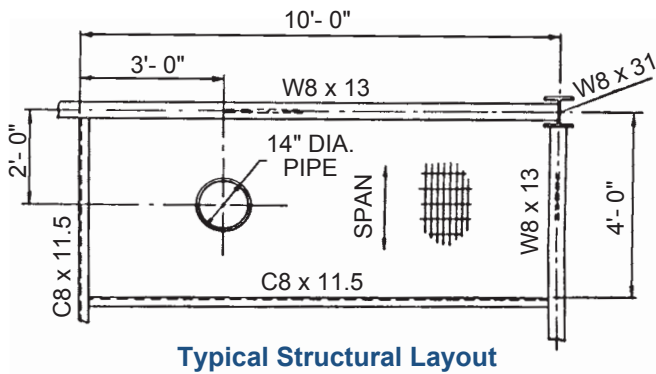

Shown above is an example of a customer supplied structural drawing (top sketch) and the corresponding grating layout drawing as furnished by Ohio Gratings (bottom sketch).

CUSTOM FABRICATION

Grating/Plate Combinations

For those flooring areas requiring the solid surface of plate, and the structural strength and removability of grating, assemblies combining checkered or smooth plate with aluminum, light duty steel, or heavy duty steel can be furnished. Unless otherwise specified, 3/16" welds, one inch long on 12" centers in each direction are used to join grating and plate. Due to the rolled in stresses inherent in plate, and the subsequent stress release and warping which can accompany galvanizing, the following limitations apply to steel grating/checker plate assemblies:

1. Light Duty Steel Grating and Plate combinations will be furnished in the mill finished or painted black conditions only. Deviation from this policy will be at customer risk, i.e., flatness tolerances will not be guaranteed for galvanized material.
2. In addition to the painted or mill finished condition, Heavy Duty Grating/Plate assemblies having bearing bars 2" x 3/8" or larger can be provided with a galvanized finish.
3. Steel Grating/Plate combinations will be installed with the plate on the BOTTOM of the grating. When installed with the plate facing up, the cross bars will be on the bottom of the grating. This will apply to steel only (not aluminum).
4. Galvanized Steel Grating/Plate will be fabricated with 1/2" diameter handling/drain hole in one corner of the plate.

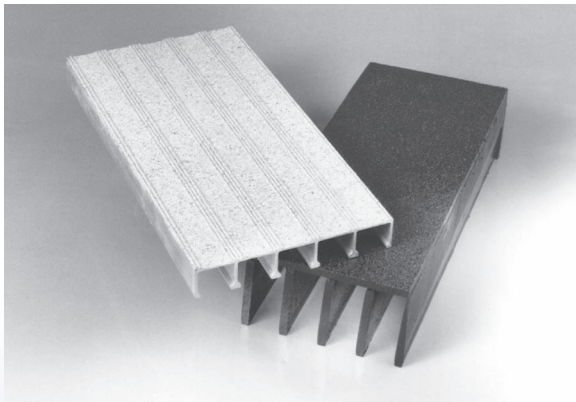

Shown above is a steel grating/solid plate assembly coated with OnGrip® Spray Traction Surface. For applications requiring the light weight or corrosion resistance of an aluminum grating / checkerplate combination, unpunched plank (shown above with OnGrip® Slip Resistant Surface) offers an economical alternative.

Serrated Rectangular Bearing Bars & Cross Bars

In order to achieve maximum skid resistance for wheel traffic, Ohio Gratings manufactures heavy duty welded steel grating with serrated rectangular bearing bars and cross bars. The rectangular cross bar design is especially suited to this application, providing a skid free surface, while at the same time offering lateral stability which is superior to the round cross rod design most common to the industry. Serrated bearing bars range from 1/4" thru 1/2" thick, while serrated cross bars are available in 1/4" and 3/8" thickness.

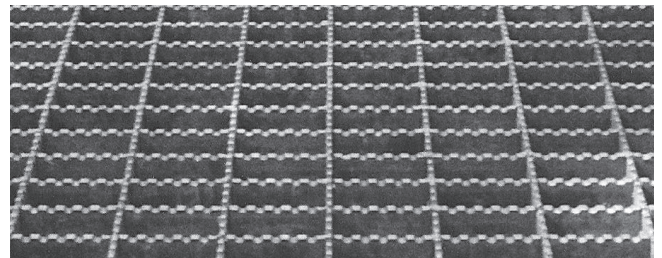

Egg-Crate Construction

Occasionally requirements call for the cross bars to be larger than standard, or in some cases, equal in size to the bearing bars. This condition may necessitate the notching of both the bearing bar and the cross bar resulting in a type of construction known as "egg-crate". Unless otherwise specified, each internal intersection is welded at two of the four corners, while the outside intersection is welded at one of the two corners. Depth of weld can vary depending upon the depth of the grating and the opening between bars. In general, egg-crate construction is limited to bars from 2" to 6" in depth and ranging from 1/4" up to 1" in thickness, with a minimum clear opening ranging from 2" to 4", depending upon bar size. The maximum panel size is typically 50 - 60 SF per piece.

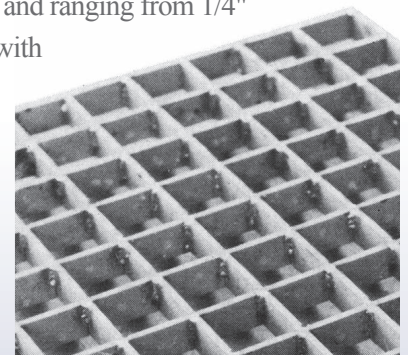

CUSTOM FABRICATION

Hinges, Locks & Lift Handles

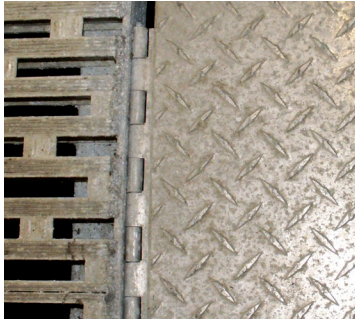

Since grating is typically used to provide multiple level flooring, quite often, grating hatches are needed to facilitate access from one level to another.

Ohio Gratings has years

of experience in fabricating grating panels with hinges and lift handles, and with locking devices for security purposes. Numerous typical details have been developed, and are on file.

Cross Bars Top & Bottom

For those areas requiring added resistance to lateral forces, Ohio Gratings manufactures heavy duty welded steel grating with cross bars on the bottom, in addition to the standard cross bars which are located on the top. Bottom cross bars can be provided in rectangular or round design, and can be positioned as close together as 2" on center. Bottom cross bars are especially helpful in resisting the lateral impact of accelerating and decelerating wheel loads.

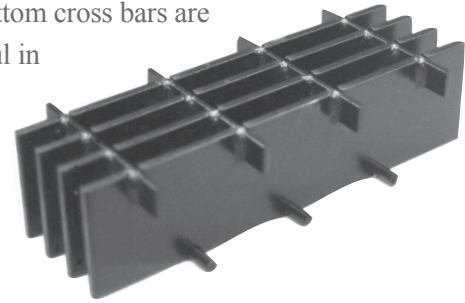

Notching/Welding

Notching is somewhat common in the industry, however, not recommended under certain conditions. Please consult Ohio Gratings for recommendations.

* Grating which is welded to an inverted angle or toe plate, and supported by the weld rather than by a bearing surface, is not recommended and should never be specified.

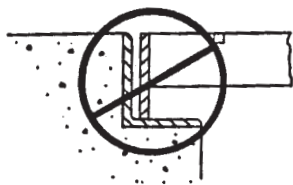

* Toe Plate

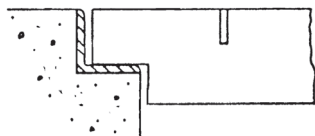

Notched Grating

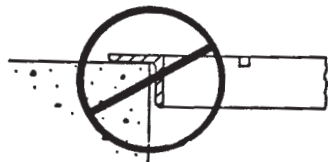

* Inverted Angle

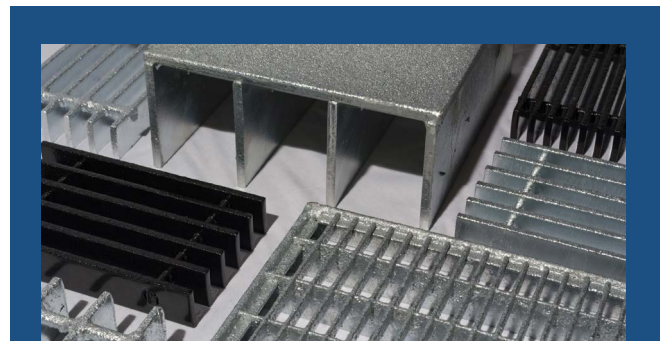

OnGrip® Spray Traction Surface

All Ohio Gratings' products are available with the OnGrip® Spray Traction Surface. This Metalspray surface has been proven to provide very high traction under the Wet Dynamic Testing conditions of ANSI-NFSI B101.3-2012. This is especially important to meet the traction requirements of the American with Disabilities Act (ADA) 2010 Regulations Section 302 for closer spaced gratings that also meet the ADA maximum opening requirement. For more details see the OnGrip® Brochure.

STANDARD INSTALLATION CLEARANCES

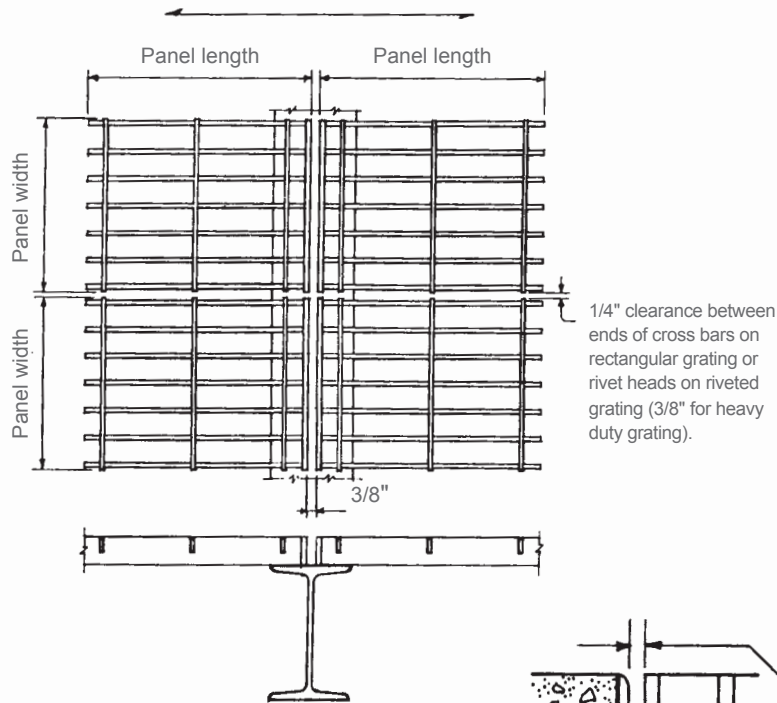

1/4" clearance between ends of cross bars on rectangular grating or rivet heads on riveted grating (3/8" for heavy duty grating).

Banding may have less depth than bearing bars for trench grating to allow drainage. Full depth banding will be provided unless otherwise specified.

Clearances shown are recommended, but may vary in accordance with dimensional tolerances.

Heavy duty grating should be designed to have structural support under each bearing bar at cutouts.

As shown in the drawing below, all rectangular cutouts are made to the next bearing bar beyond the penetration with a clearance not to exceed bearing bar spacing.

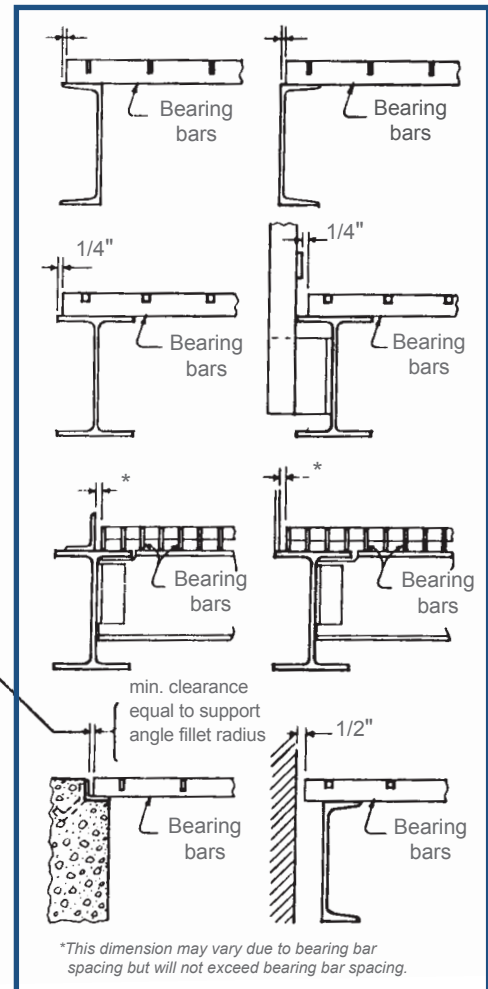
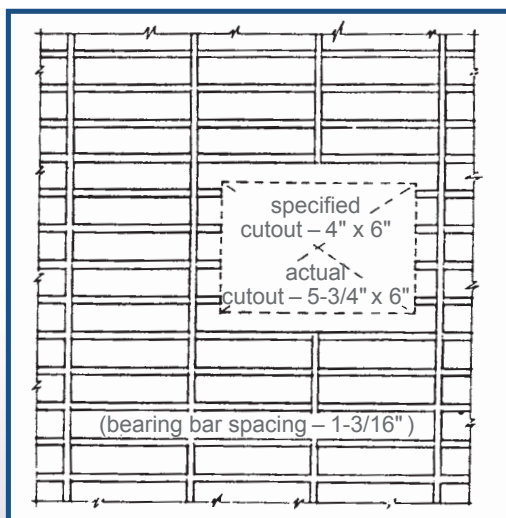

*This dimension may vary due to bearing bar spacing but will not exceed bearing bar spacing.

Cutouts for circular obstructions are recommended to be at least 2" larger in diameter than the obstruction. It is further recommended that cutouts for all piping 4" or less be made in the field.

General Recommendations for Grating Installation

- Gratings must be installed with cross bars on top side.
- Notching of bearing bars at supports to maintain proper elevation is generally not recommended. If notching is required for installation, manufacturer should be consulted.
- Metal should always be used for all grating supports.
- A minimum of 1" bearing shall be provided for Aluminum and Light Duty Steel Grating. For Heavy Duty Steel Grating, 1" minimum bearing shall be provided for bearing bar depths up to 2-1/4", and 2" minimum bearing shall be provided for depths of 2-1/2" and over. This bearing surface does not include the support angle fillet radius noted above.

GRATING TOLERANCES

Light Duty Steel Grating & Aluminum Grating

Overall Dimensions and Squareness

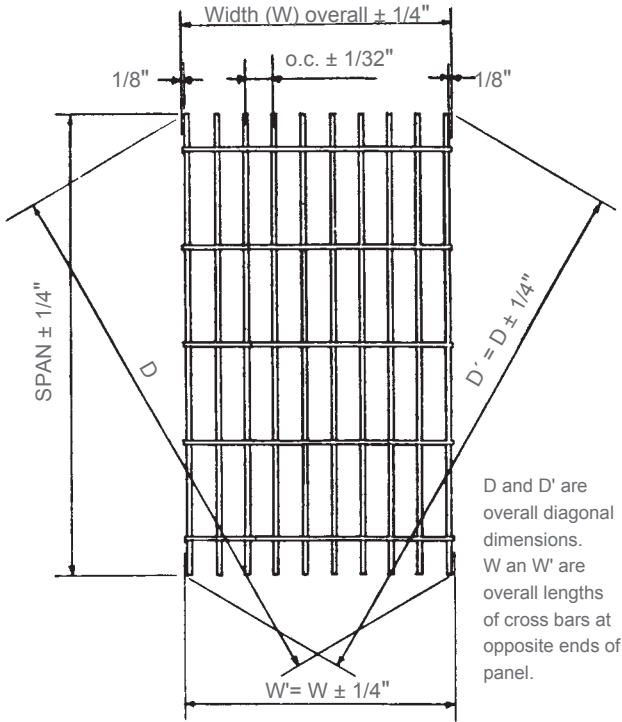

Cross Bar Alignment and Spacing

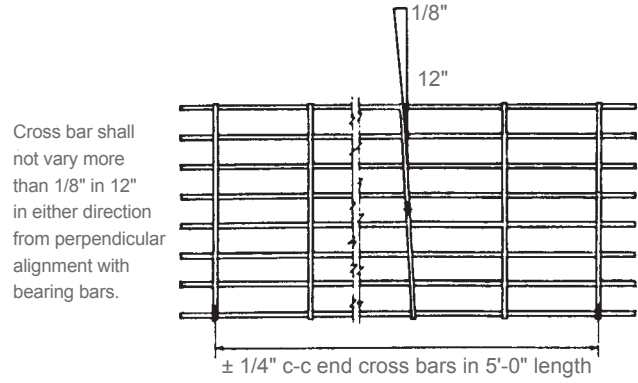

Cross Bar Location

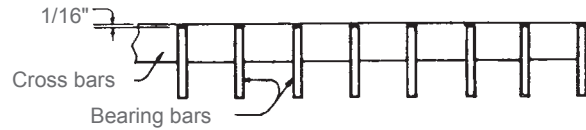

Bearing Bar Lean

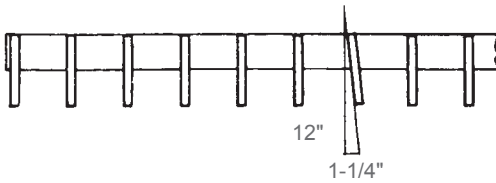

Cross Bar Lean

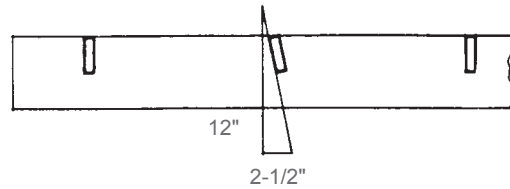

Longitudinal Bow

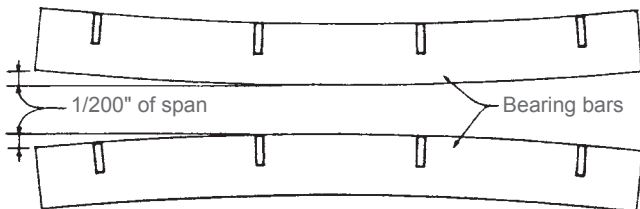

Transverse Bow (Before fastening to supports)

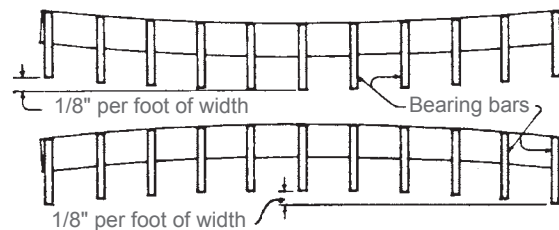

GRATING TOLERANCES

Heavy Duty Steel Grating

Overall Dimensions and Squareness

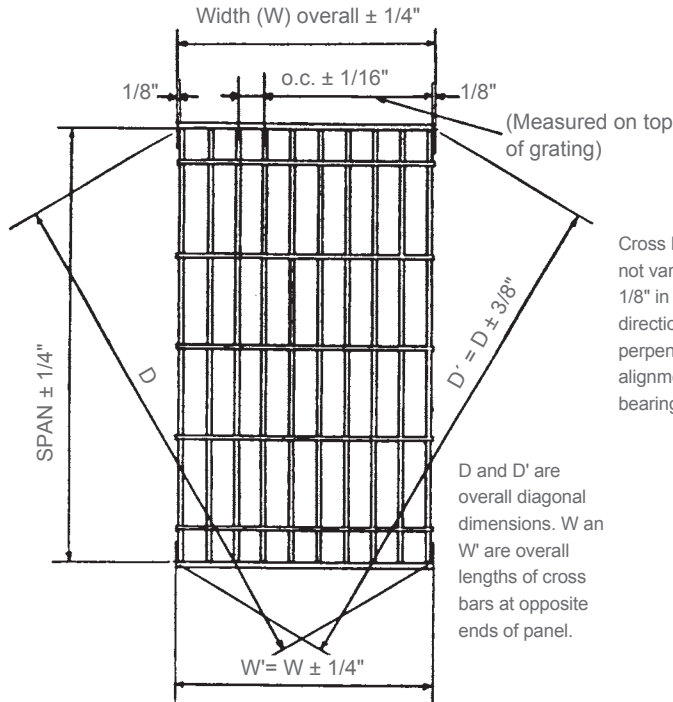

Cross Bar Alignment and Spacing

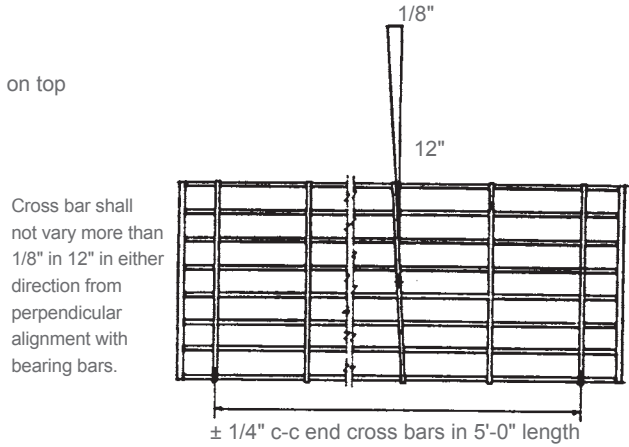

Cross Bar Location



Bearing Bar Lean

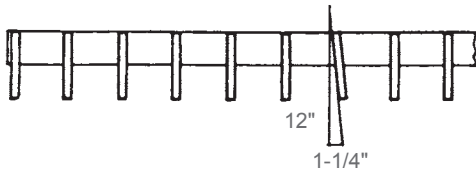

Cross Bar Lean

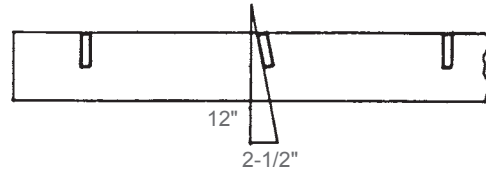

Longitudinal Bow

(Before fastening to supports)

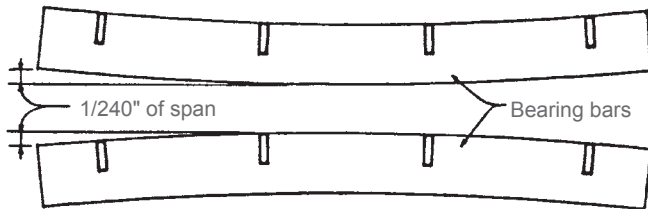

Transverse Bow

(Before fastening to supports)

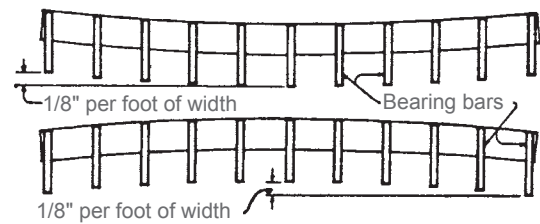

WELDING STANDARDS

Light Duty Steel Grating & Aluminum Grating

The welding standards shown here apply to those gratings and treads having a clear opening of not less than 5/8" between bearing bars and those galvanized as per ASTM A-123.

Toe Plates

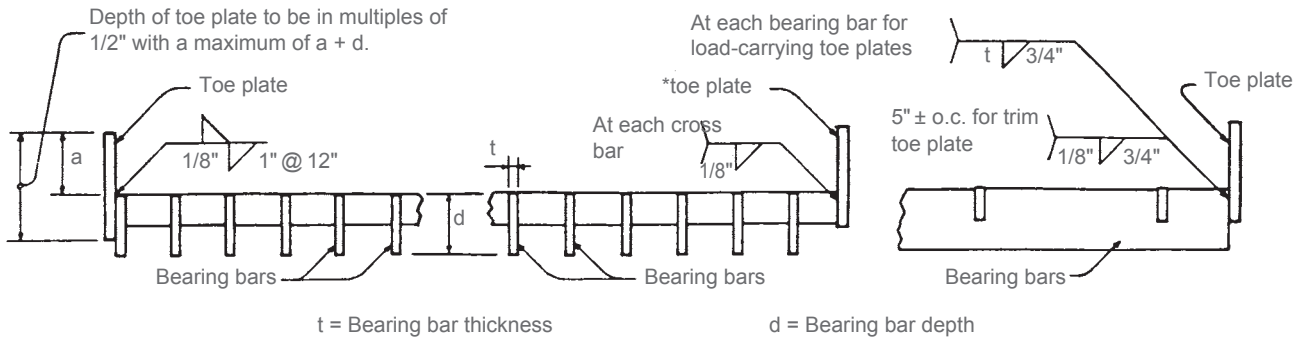

*Example shown occurs at a diagonal or circular cutout.

Banding

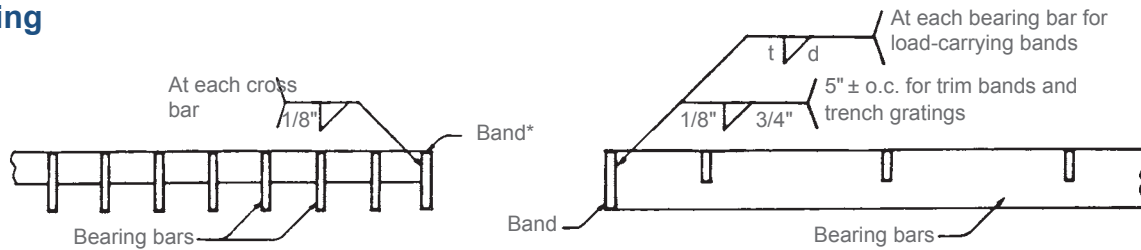

*Example shown occurs at a diagonal or circular cutout. Since the outside bearing bar becomes the edge bar of a panel width, side bands are never specified. Full depth banding will be provided unless otherwise specified.

Stair Treads

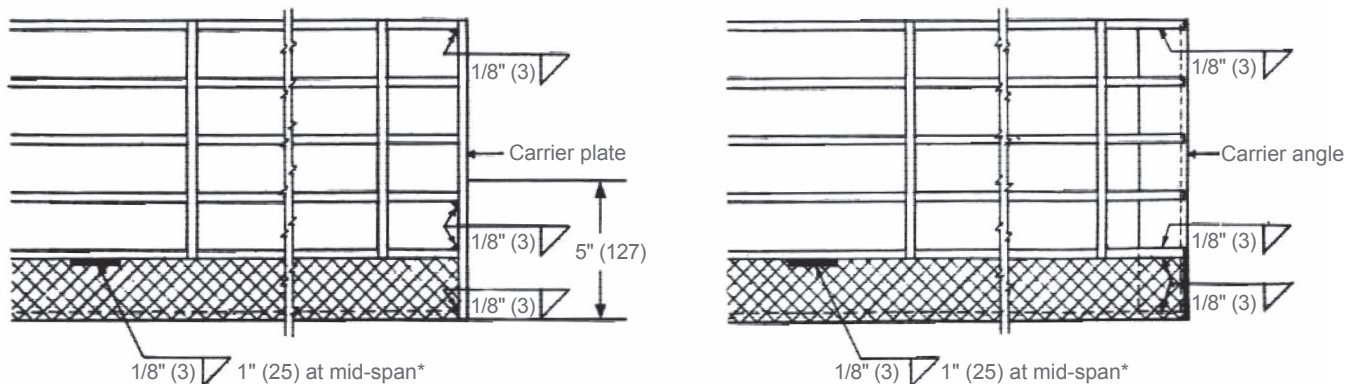

When carrier plates are used, the bearing bars and the nosing in the front five inches shall be welded to the carrier plate as shown.

On treads over 9-3/4" (248) wide, weld end of center bar also.

*Treads spanning 4' (1.2 m) or more shall have two welds, located at the third points.

WELDING STANDARDS

Heavy Duty Steel Grating

The welding standards shown here apply to those gratings and treads having a clear opening of not less than 5/8" between bearing bars and those galvanized as per ASTM A-123.

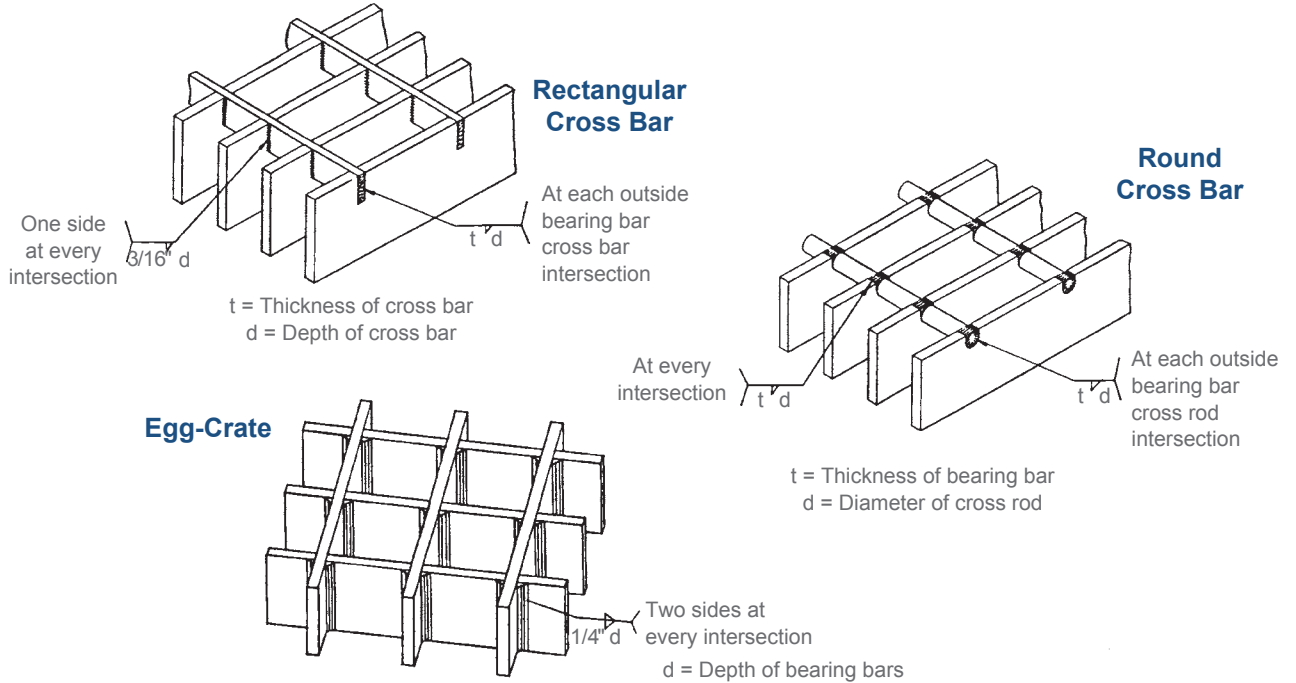

Toe Plates

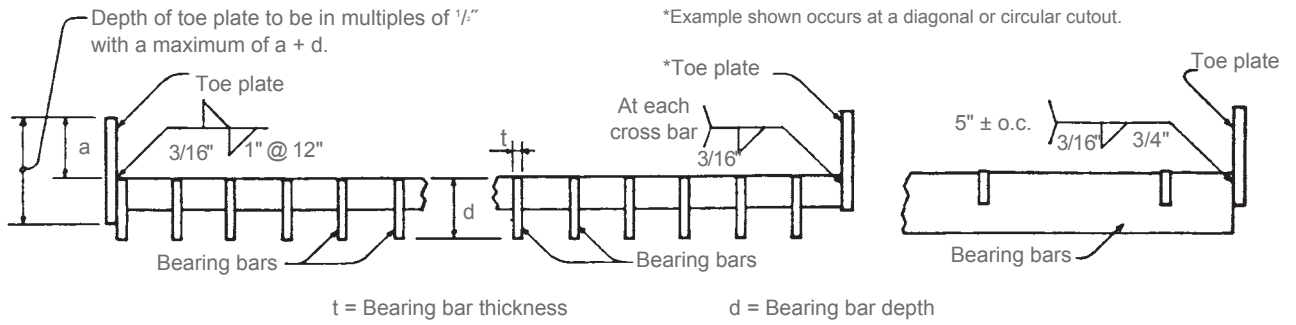

Banding

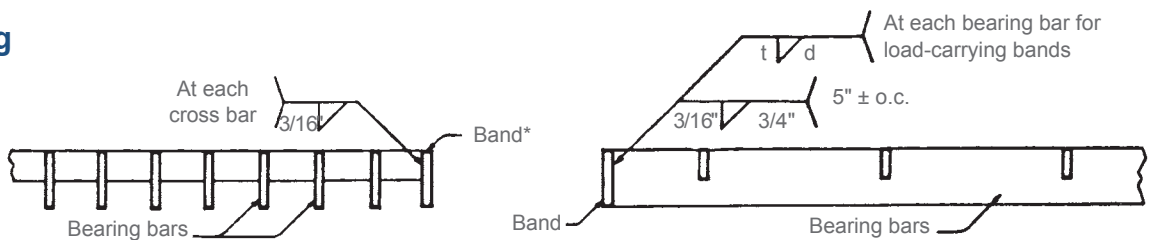

For depth less than 2-1/2" weld one side at top. For depth 2-1/2" or greater, weld one side at top, opposite side at bottom; or weld exceeding one-half depth on one side only. Minimum thickness = 1/4" For standard banding, band bar is same depth as bearing bars.

GLOSSARY

ANCHOR

A device by which grating is attached to its supports.

BAND

A flat bar welded to the end of a grating panel, or along the line of a cutout, and extending neither above nor below the bearing bars.

Load-Carrying Band: A band used in a cutout to transfer the load from unsupported bearing bars in the cutout to the supported bearing bars.

Trim Band: A band which carries no load, but is used chiefly to improve appearance.

BEARING BARS

Load-carrying bars made from steel strip or slit sheet or from rolled or extruded aluminum and extending in the direction of the grating span.

BEARING BAR CENTERS

The distance center to center of the bearing bars.

CARRIERS

Flats or angles which are welded to the grating panel and nosing of a stair tread and are bolted to a stair stringer to support the tread.

CLEAR OPENING

The distance between faces of bearing bars in a rectangular grating, or between a bent connecting bar and a bearing bar in a riveted grating.

CROSS BARS

The connecting bars, made from steel strip, slit sheet, or rolled bars, or from rolled or extruded aluminum, which extend across the bearing bars, usually perpendicular to them. They may be bent into a corrugated or sinuous pattern and, where they intersect the bearing bars, are welded, forged or mechanically locked to them.

CROSS BAR CENTERS

The distance center to center of the cross bars.

CURVED CUT

A cutout following a curved pattern.

CUTOUT

An area of grating removed to clear an obstruction or to permit pipes, ducts, columns, etc. to pass through the grating.

ELECTRO-FORGED

A process combining hydraulic pressure and heat fusion to forge bearing bars and cross bars into a panel grid.

END DIMENSION

The distance from an end of grating to center of first cross rod (except welded Heavy Duty, where distance is from edge of grating to back of first cross rod).

FILLER BAR

A bar welded between two support bearing bars to close the spacing.

FINISH

The coating, usually painted or galvanized which is applied to the grating.

FLUSH TOP GRATING

A type of pressure-locked grating in which the cross bars and bearing bars are in the same plane relative to the top surface of the grating.

GRATING

An open grid assembly of metal bars, in which the bearing bars, running in one direction, are spaced by rigid attachment to cross bars running perpendicular to them or by bent connecting bars extending between them.

HINGED PANELS

Grating panels which are hinged to their supports or to other grating parts.

I-BAR

An extruded aluminum bearing bar having a cross sectional shape resembling the letter "I".

INTERLOCKING GRATING

Plank Grating – Snap Lock Plank grating with male and female sides that lock together.

GLOSSARY

INTERSECTION AREA

The point where the bearing bar and cross bar intersect or cross. In heavy duty grating with a rectangular cross bar; an intersection has four (4) sides.

LENGTH

The dimension of a grating panel measured parallel to the bearing bars. Also referred to as span.

MARKING

(Mark Number) Used to identify each unique piece.

NOSING

A special L-section member serving as the front or leading edge of a stair tread, or of grating at the head of a stair.

NOTCHED BAR

A cut out in the bearing bar. A burn out or punch.

ONGRIP® SPRAY TRACTION SURFACE

Metal Arc-Spray Surface for high traction.

PRESSURE-LOCKED GRATING

Pressure-locked means bearing bars are locked in position by cross bar deformation instead of riveting or welding.

Several proven methods are:

- Expansion of an extruded or drawn tubular cross bar
- Extruded cross bar deformed or swaged between bearing bars
- Press assembly of rectangular cross bars into slotted bearing bars.

RADIALLY CUT GRATING

Rectangular grating which is cut into panels shaped as annular segments, for use in circular or annular areas.

RETICULINE BAR

A sinuously bent connecting bar extending between two adjacent bearing bars, alternately contacting and being riveted to each.

RIVET CENTERS

The distance center to center of rivets along one bearing bar.

RIVETED GRATING

Grating composed of straight bearing bars and bent connecting bars, which are joined, at their contact points, by riveting.

SERRATED GRATING

Grating which has the top surfaces of the bearing bars or cross bars, or both, notched.

SKEW CUT

A fabricated diagonal cut.

SPAN OF GRATING

The distance between points of grating support, or the direction of this dimension. Also referred to as length.

STRAIGHT CUT

That portion of the cut edge or cutout of a grating which follows a straight line.

SWAGING

A method of altering the cross-sectional shape of a metal bar by pressure applied through dies.

TOE PLATE

A flat bar attached against the outer edge of a grating or rear edge of a tread, and projecting above the top surface of grating or tread to form a lip or curb.

TREAD

A panel of grating having carriers and nosing attached by welding, and designed specifically to serve as a stair tread.

WELDED GRATING

Grating in which the bearing bars and cross bars are joined at all of their intersections by either a resistance weld or conventional hand welding.

WIDTH

The overall dimension of a grating panel, measured perpendicular to the bearing bars, and in the same direction as the cross bars.

ORDERING INFORMATION

GRATING

1. Description:

a. Aluminum:

- Aluminum Flush Top SGF Series
- Aluminum Rectangular Bar SG Series
- Aluminum I-Bar SGI Series
- Aluminum Lite Bar
- Aluminum Dove Tail ADT Series
- Aluminum Riveted AR Series
- Aluminum Plank Series

b. Heavy Duty Steel:

- Heavy Duty Welded Steel W Series
- Heavy Duty Welded Steel WH Series
- Heavy Duty Riveted Steel R Series

c. Light Duty Steel:

- Welded Carbon Steel W Series
- Dove Tail Carbon Steel DT Series
- Swaged Carbon Steel SGCS Series
- Swaged Stainless Steel SGSS Series
- Riveted Carbon Steel R Series

2. Size and Type: (Bar grating)

- Bearing bar size
- Bearing bar spacing, center-to-center (face-to-face for riveted grating)
- Cross bar or rivet spacing, center-to-center

3. Surface:

- Plain
- Serrated
- Striated (I-Bar)
- OnGrip® Spray Traction Surface

4. Size & Punch/Pattern: (Aluminum Plank grating)

- Plank size and type
- Unpunched
- Rectangular Punched
 - Upset Pattern (OGI)
 - Upset Pattern (WACO)
 - Plain Pattern
- Square Punched
 - Upset Pattern
 - Plain Pattern
- Round Punched
 - 1-3/16" Diameter In-Line Pattern
 - 1" Diameter Staggered Pattern
- ADA Diagonal Pattern

5. A Drawing Showing: (if layout is complicated)

- Area to be covered
- Span (direction of bearing bars)
- Method of support
- All critical dimensions
- Banding or toe plate

6. Type of Anchorage:

- Grating clamp
- Plank clip
- Saddle clip
- Anchor block
- Countersunk land (aluminum only)
- Tack weld
- Z clip
- Plank lug

Note: Grating should always be held down by some positive means. (see page 98)

7. Finish:

a. Aluminum:

- Mill Finish
- Cleaned & Etched
- A-31 1/2 hour Clear Anodizing
- A-41 1 hour Clear Anodizing

b. Carbon Steel:

- Mill Finish
- Manufacturer's Standard Black Paint
- Powder Coat
- Galvanized

c. Stainless Steel:

- Mill Finish
- Sandblast (used to help minimize the discoloration caused by welding Heavy Duty Stainless Steel grating)
- Passivated

STAIR TREADS

1. Description: See Grating, Item 1

2. Size and Type: (Bar grating) See Grating, Item 2

3. Surface: See Grating, Item 3

4. Size and Punch/Pattern: (Aluminum Plank grating):

- See Grating, Item 4
- Type "F"

5. Type of Nosing:

- Checker plate – standard for carbon steel treads
- OnGrip® Spray Traction Surface
- Grooved – an extruded aluminum nosing standard on aluminum treads
- AAON - Aluminum Abrasive OnGrip® Nosing Bolt On

6. Dimensions:

- Width of tread, including nosing
- Span (length of bearing bars)
- End plate dimensions "A" and "B" (see page 35)

7. Number of Treads:

8. Finish: See Grating, Item 7

ALUMINUM GRATING FRAMES

1. Frame Size: (corresponds with grating size)

2. Description:

- Stock lengths
- A detailed drawing or accurate measurements for fabricated frames

3. Supplementary anchor straps & spacing, if required:

4. Finish:

- Mill Finish
- Powder Coated

5. Nail Holes and Location: , if required

Architectural METAL SOLUTIONS



Photo Courtesy: Patrick Walker



OGI ARCHITECTURAL
METAL SOLUTIONS

Ask about our Architectural Catalog!

www.ohiogratings.com

TOLL FREE: 1-800-321-9800

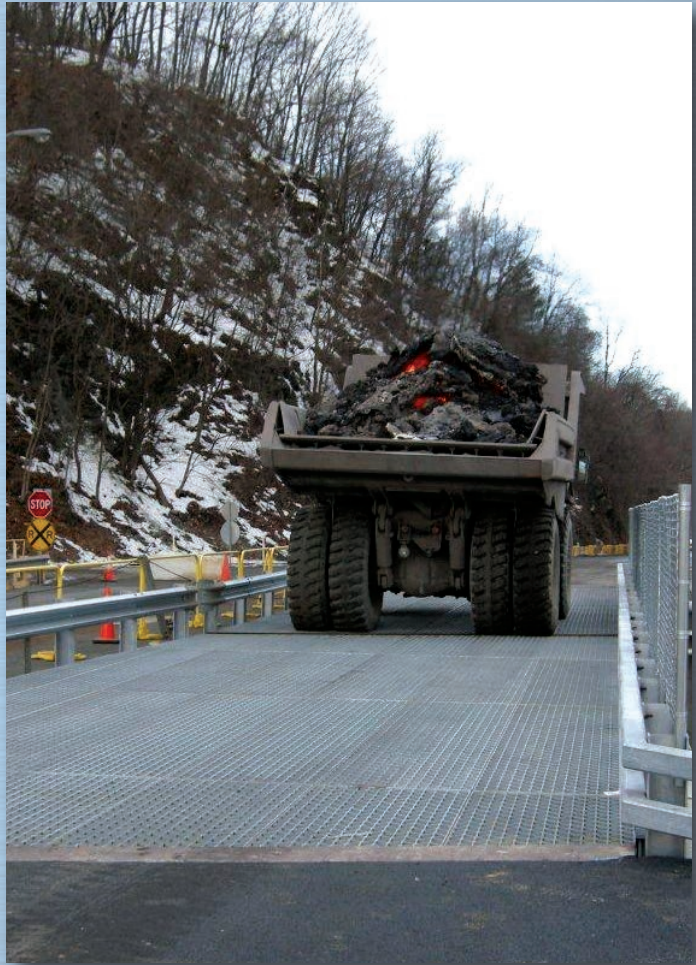

NAAMM NATIONAL ASSOCIATION OF ARCHITECTURAL METAL MANUFACTURERS
NOMMA National Ornamental & Miscellaneous Metals Association

YOUR INDUSTRY CONNECTION
MHEDA
 Member

MHI
 Member Company

CCI Powder Coating Institute

SMA Storage Manufacturers Association
 Green Products

RMI
 RACK MANUFACTURERS INSTITUTE
 Member Company



OHIO GRATINGS, INC.

5299 Southway Street SW | Canton, OH 44706
 1-800-321-9800 | Fax 330-477-7872 | www.ohiogratings.com