

Plan View

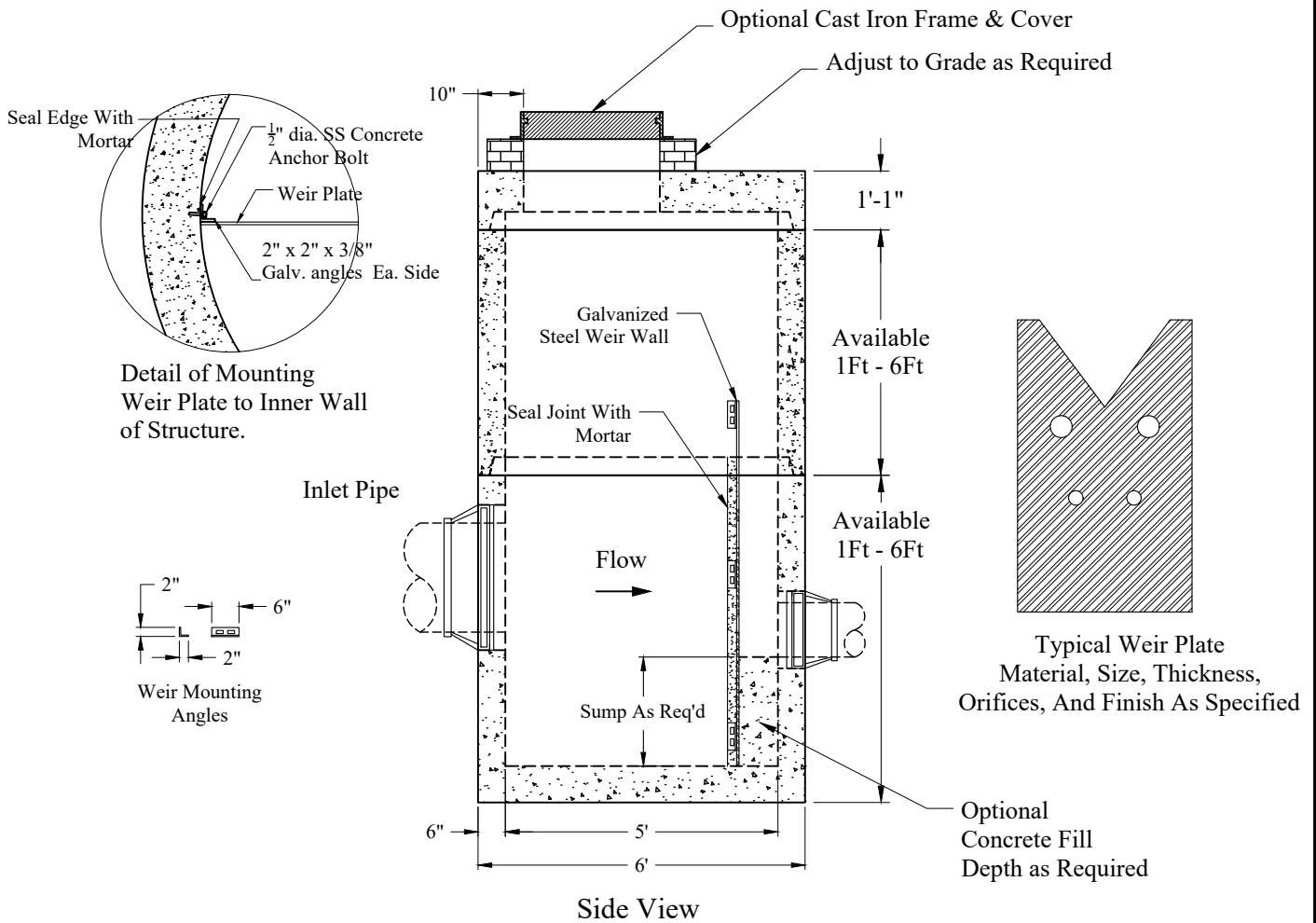

Side View

General Notes

1. Steel Reinforcement Conforms to Latest ASTM Specification:
ASTM A-615, Grade 60 Black Deformed Bars
ASTM A-185 Welded Wire Fabric
0.12 Sq. In./Lineal Ft. And 0.12 Sq. In.(Both Ways) Base Bottom
2. Concrete: $f_c = 4,000$ psi @ 28 Days Minimum, Type III Cement
3. Butyl Rubber Joint Sealant Provided Conforms to ASTM C-990 And Federal Spec SS-S-210A
4. HS-20 Design Loading Conforms to Latest Specifications
ASTM C478, AASHTO M199 Precast Reinforced Concrete Manhole Sections
5. One Pour Monolithic Base Section

**Phoenix
Precast
Products**

Standard 5' Diameter
Outlet Control Structure
With Metal Weir Plate
And Concrete Ballast

P/N: Custom As Required

Concord, NH 03301

77 Regional Drive