

Phoenix Precast Products

Phoenix Precast Products

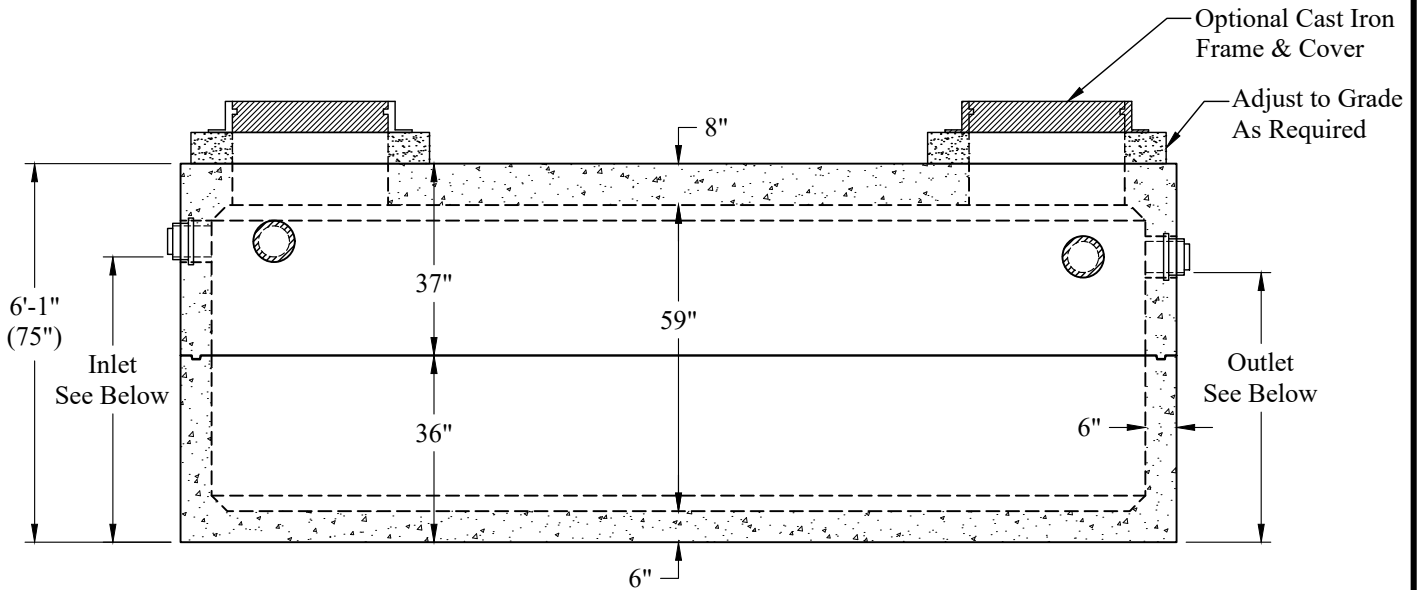

**General Notes:**

1. Concrete:  $f_c = 5,000$  psi @ 28 Days Minimum
2. Steel Reinforcement Conforms to Latest ASTM Specifications: ASTM-A615 Grade 60 Rebar
3. Flexible Sleeves Provided On All Pipe Connections
4. Butyl Rubber Joint Sealant Provided
5. Internal PVC Baffles Available Upon Request  
Inlet: Shall Penetrate at Least 9" Below the Liquid Level, But Not Deeper Than the Outlet Baffle.  
Outlet: Shall Extend Below the Surface of the Liquid Equal to 40% of the Liquid Depth (24").
6. Other Inlet/Outlet Pipe Sizes Available
7. Asphalt Coating Applied To All Exterior Surfaces If Required

4" PVC Inverts: Inlet - 56"      Outlet - 53"  
 6" PVC Inverts: Inlet - 55"      Outlet - 52"

**Liquid Levels: 7'-0" x 15'-0" = 787 Gals/VF**

4" PVC = 3,085 Gallons  
 6" PVC = 3,014 Gallons

**Est. Weight:**

Top:	20,400 Lbs
Bottom:	18,000 Lbs
<b>Total:</b>	<b>38,400 Lbs</b>

Phoenix  
 Precast  
 Products

**3,000 Gallon  
 HD Tank**  
 P/N: ST-3000HD