

C:\Users\ironville\OneDrive - Sabbow & Co Inc\ray r Web Site 2024\Septic Tanks2
 Compartment HD Mid-Seam Large_HD_2 Comp_1600-1000_Tank_Rev5.dwg

Phoenix Precast Products

Phoenix Precast Products

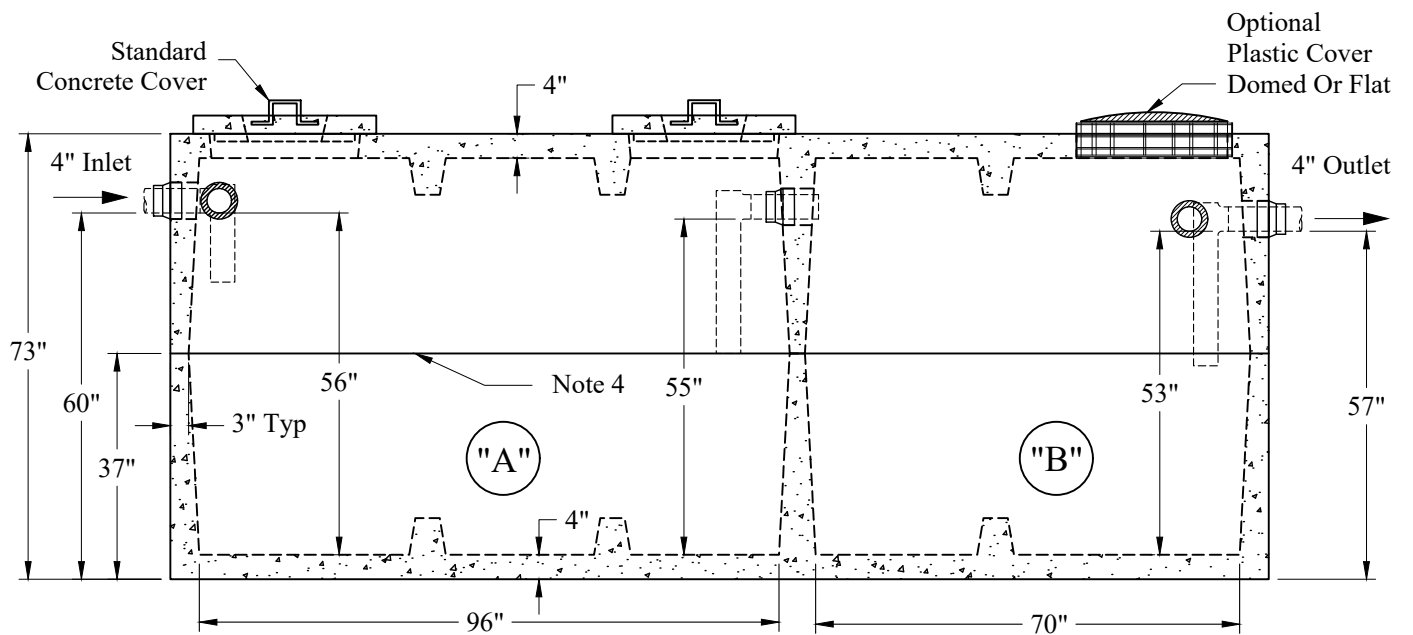
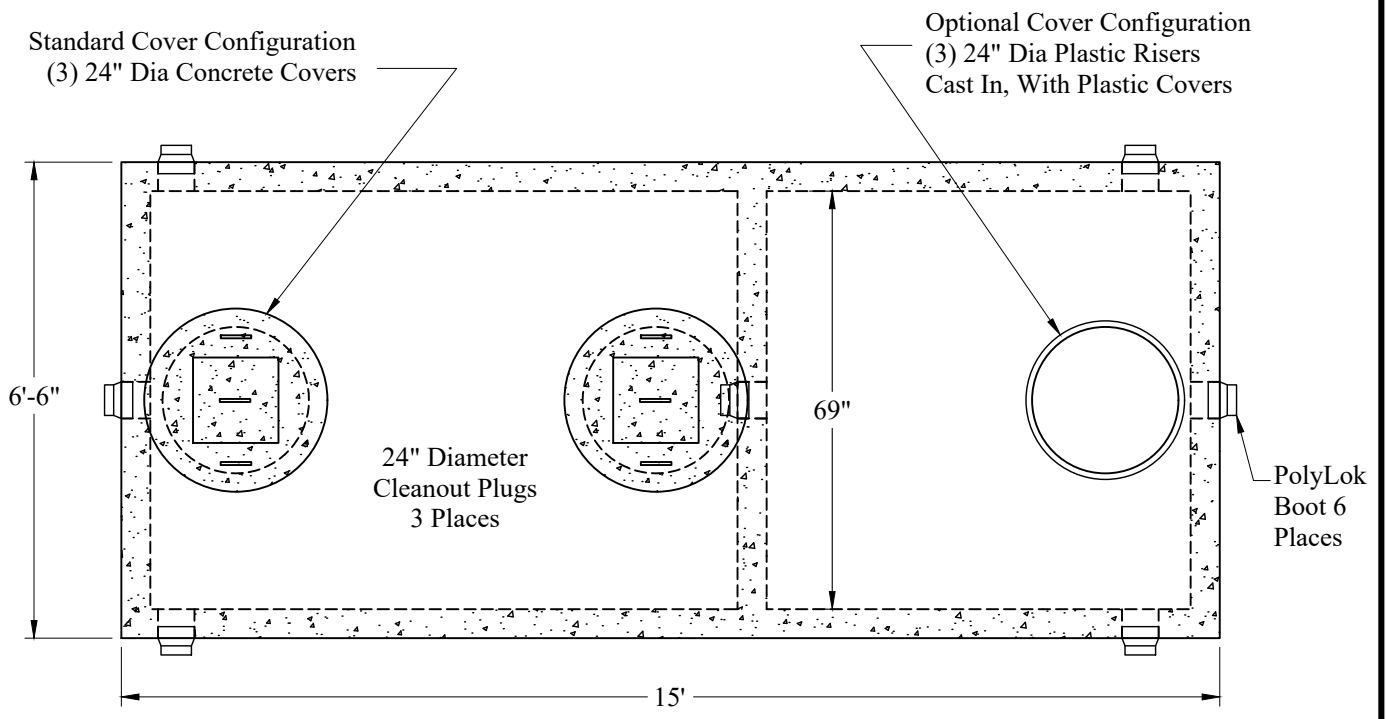

"A" Liquid Level = 355 Gals/VF (30 Gals/In)
 "B" Liquid Level = 262 Gals/VF (22 Gals/In)
 "A" = 1,598 Gals
 "B" = 1,158 Gals
 Total = 2,756 Gals

Est Weight:
 Top: 11,780 Lbs
 Base: 11,790 Lbs
 Total: 23,570 Lbs

- General Notes**
1. Steel Reinforcement Conforms to Latest ASTM Specifications: ASTM-A615 Grade 60 Rebar
 2. Concrete: $f_c = 4,000$ psi @ 28 Days Minimum
 3. Flexible Sleeves Used On All Pipe Openings
 4. Butyl Rubber Joint Sealant Provided
 5. Internal PVC Baffles Available
- Inlet:
 Shall Penetrate at Least 9" Below the Liquid Level But Not Deeper Than the Outlet Baffle.
- Outlet:
 Shall Extend Below the Surface of the Liquid Equal to 40% of the Liquid Depth (21").
6. HD Tanks: 3' - 6' Cover Max, Non-Traffic

Phoenix Precast Products	1,600/1,000 Gallon HD 2 Compartment Tank
	P/N: ST-1600/1000HD P/N: ST-1600/1000PLSHD