

Standard Cover Configuration  
(4) 24" Dia Concrete Covers

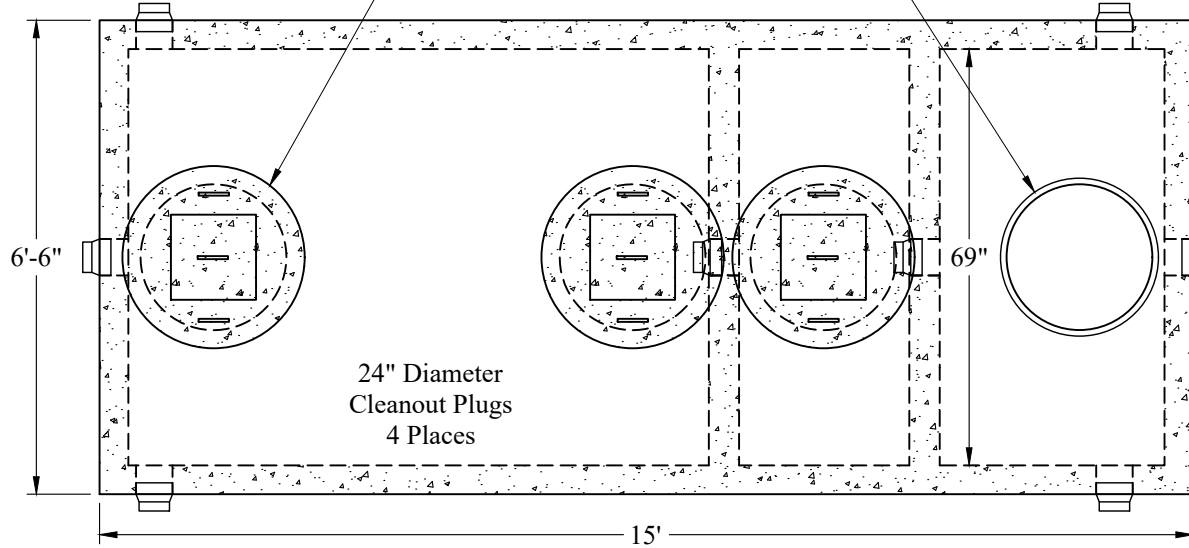

Optional Cover Configuration  
(4) 24" Dia Plastic Risers  
Cast In, With Plastic Covers

24" Diameter  
Cleanout Plugs  
4 Places

PolyLok  
Boot 6  
Places

Standard  
Concrete Cover

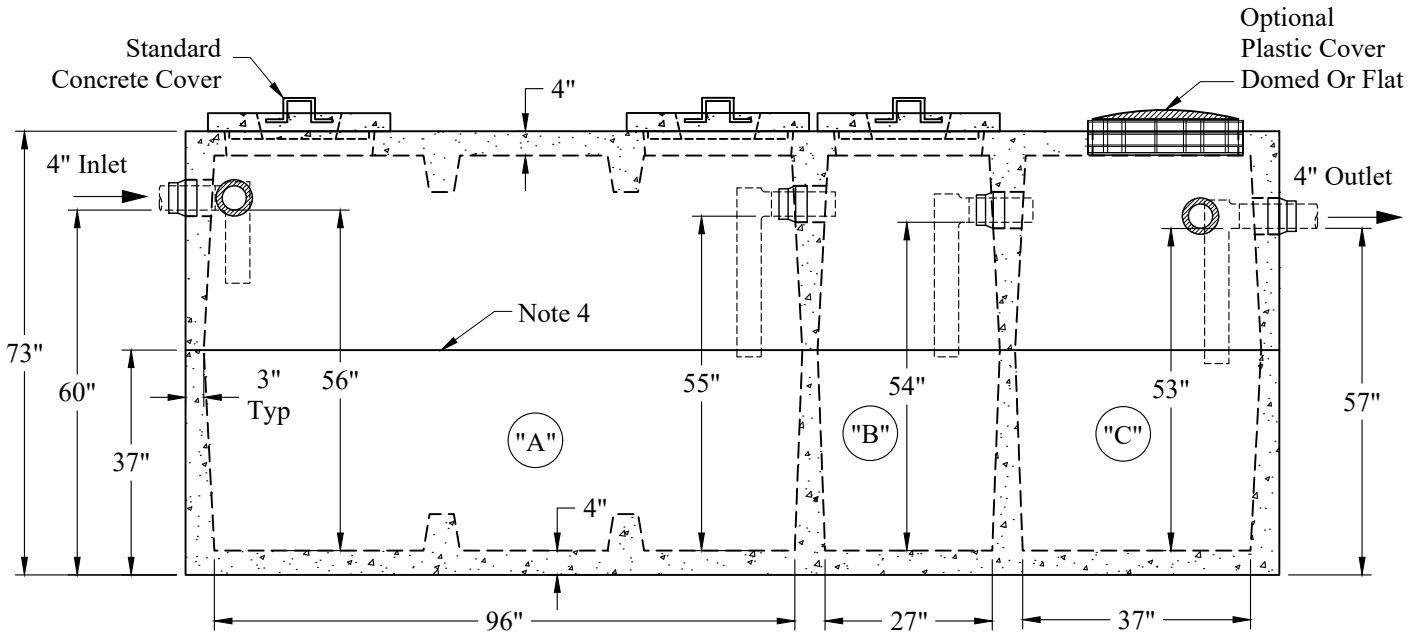

Optional  
Plastic Cover  
Domed Or Flat

Note 4

"A" Liquid Level = 355 Gals/VF (30 Gals/In)

"B" Liquid Level = 105 Gals/VF (9 Gals/In)

"C" Liquid Level = 143 Gals/VF (12 Gals/In)

"A" = 1,650 Gals

"B" = 486 Gals

"C" = 636 Gals

Total = 2,772 Gals

Est Weight:

Top: 12,400 Lbs

Base: 12,500 Lbs

Total: 24,900 Lbs

**General Notes**

1. Steel Reinforcement Conforms to Latest ASTM Specifications: ASTM-A615 Grade 60 Rebar
  2. Concrete:  $f_c = 4,000$  psi @ 28 Days Minimum
  3. Flexible Sleeves Used On All Pipe Openings
  4. Butyl Rubber Joint Sealant Provided
  5. Internal PVC Baffles Available
- Inlet:**  
Shall Penetrate at Least 9" Below the Liquid Level But Not Deeper Than the Outlet Baffle.
- Outlet:**  
Shall Extend Below the Surface of the Liquid Equal to 40% of the Liquid Depth (21").
6. HD Tanks: 3' - 6' Cover Max, Non-Traffic

Phoenix  
Precast  
Products

Large HD  
3 Compartment Tank

P/N: ST-1500/440/575HD

P/N: ST-1500/440/575PLSHD

Concord, NH 03301