

Standard Cover Configuration
(3) 24" Dia Concrete Covers

Optional Cover Configuration
(3) 24" Dia Plastic Risers
Cast In With Plastic Covers

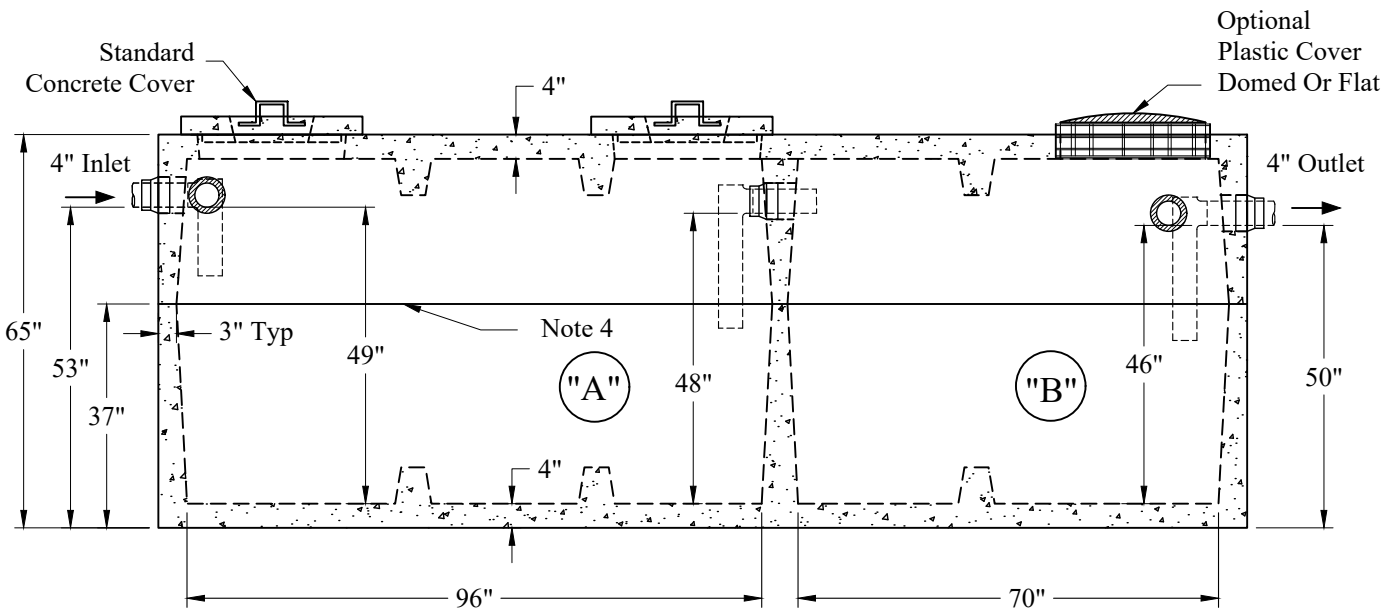
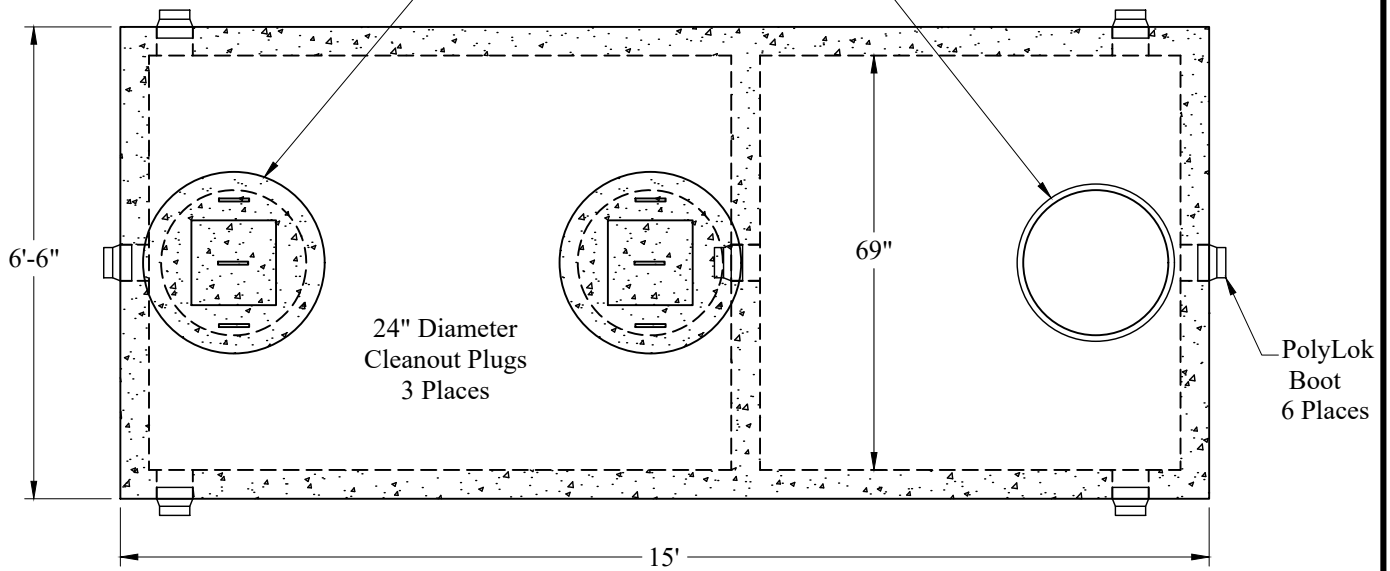

"A" Liquid Level = 355 Gals/VF (30 Gals/In)
 "B" Liquid Level = 262 Gals/VF (22 Gals/In)
 "A" = 1,392 Gals
 "B" = 1,003 Gals
 Total = 2,395 Gals

Est Weight:
 Upper: 9,800 Lbs
 Lower: 11,790 Lbs
 Total: 21,590 Lbs

General Notes

1. Steel Reinforcement Conforms to Latest ASTM Specifications: ASTM-A615 Grade 60 Rebar
 2. Concrete: $f_c = 4,000$ psi @ 28 Days Minimum
 3. Flexible Sleeves Used On All Pipe Openings
 4. Butyl Rubber Joint Sealant Provided
 5. Internal PVC Baffles Available
- Inlet:
 Shall Penetrate at Least 9" Below the Liquid Level But Not Deeper Than the Outlet Baffle.
- Outlet:
 Shall Extend Below the Surface of the Liquid Equal to 40% of the Liquid Depth (19").
6. LD Tanks: 3' Cover Max, Non-Traffic

Phoenix
 Precast
 Products

1400/1000 Gallon LD
 2 Compartment Tank

P/N: ST-1400/1000LD
 P/N: ST-1400/1000PLSLD