

C:\Users\rrottille\OneDrive - Sabbow & Co Inc\way r Web Site 2024\Septic Tanks\2 Compartment LD Mid-Seam\1250-500\_LD 2-Comp Mid-Seam Tank (New Form)\_Rev7.dwg

Phoenix Precast Products

Phoenix Precast Products

Standard Cover Configuration  
(3) 24" Dia Concrete Covers

Optional Cover Configuration  
(3) 24" Dia Plastic Risers  
Cast In, With Plastic Covers

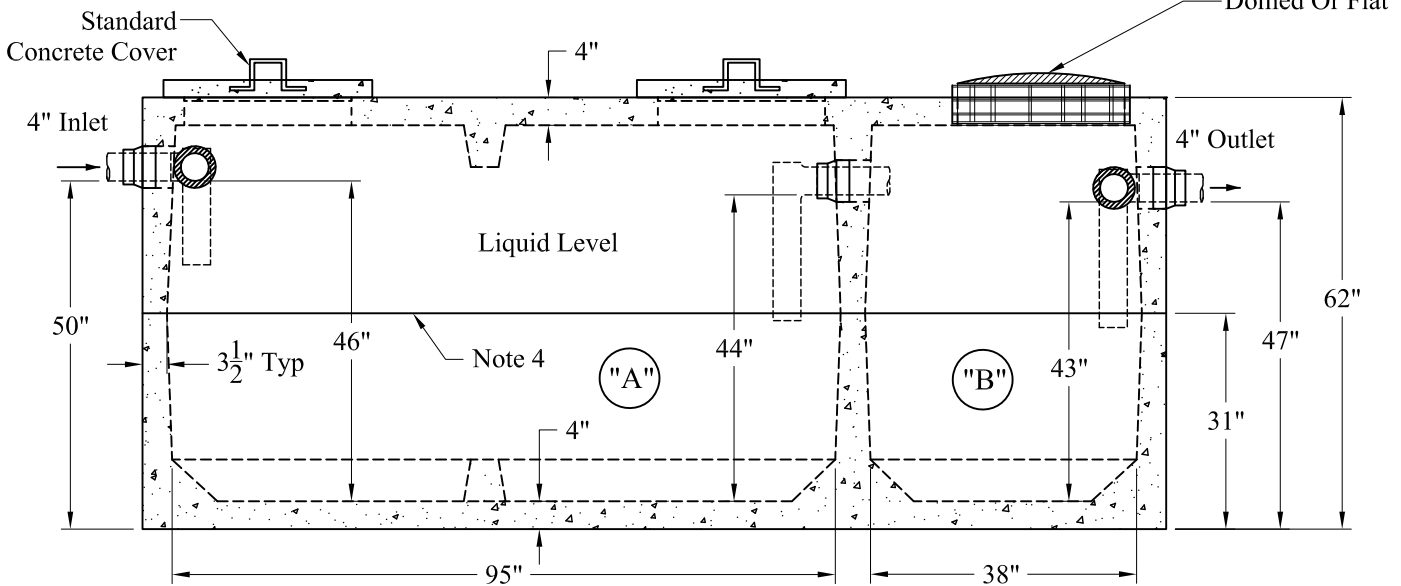
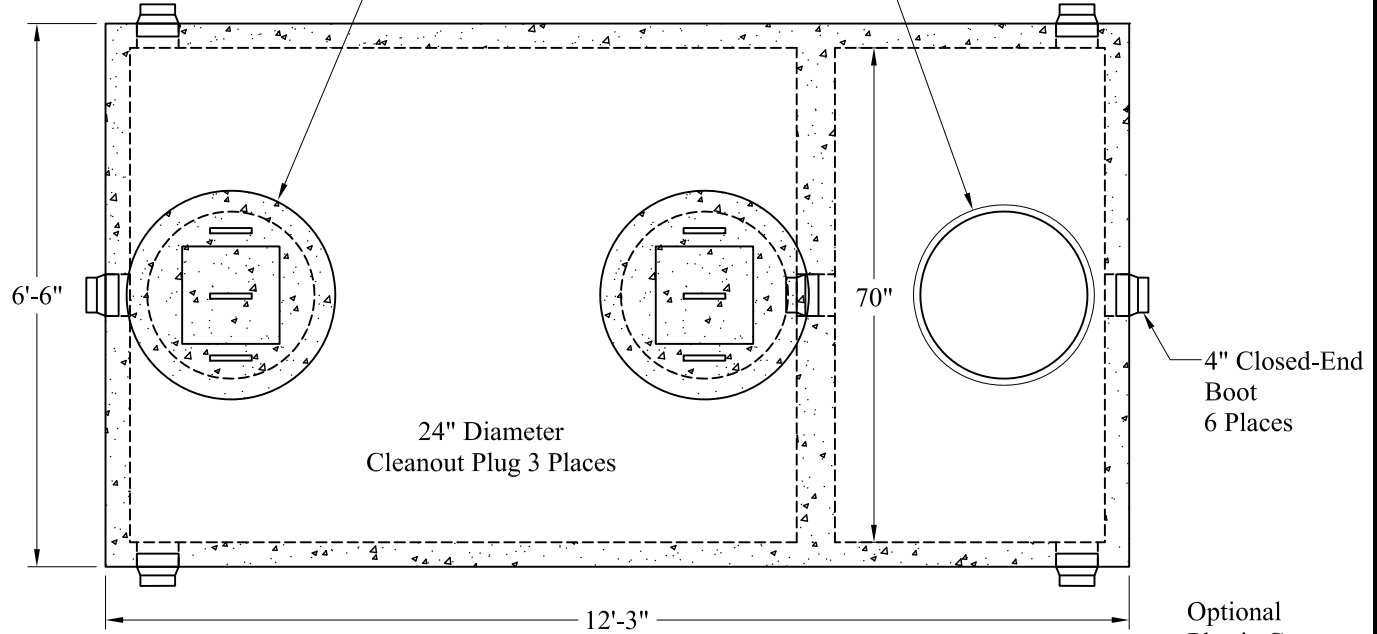

"A" Liquid Level = 345 Gals/VF (29 Gals/In)

"B" Liquid Level = 140 Gals/VF (12 Gals/In)

"A" = 1,276 Gals

"B" = 516 Gals

Total = 1,792 Gals

Est Weight:

Upper: 7,900 Lbs

Lower: 9,360 Lbs

Total: 17,260 Lbs

**General Notes**

1. Steel Reinforcement Conforms to Latest ASTM Specifications: ASTM-A615 Grade 60 Rebar
2. Concrete:  $f_c = 4,000$  psi @ 28 Days Minimum
3. Flexible Sleeves Used On All Pipe Openings
4. Butyl Rubber Joint Sealant Provided
5. Internal PVC Baffles Available

Inlet:

Shall Penetrate at Least 9" Below the Liquid Level But Not Deeper Than the Outlet Baffle.

Outlet:

Shall Extend Below the Surface of the Liquid Equal to 40% of the Liquid Depth (17").

6. LD Tanks: 3' Cover Max, Non-Traffic

Phoenix  
Precast  
Products

1250/500 Gallon LD  
2 Compartment Tank

P/N: ST-1250/500LD

P/N: ST-1250/500PLSLD

Concord, NH 03301