

C:\Users\rouille\OneDrive - Sabow & Co Inc\ray r Web Site 2024\Septic_Tanks\2
 Compartment LD Mid-Seam\500-500_Light Duty_2-Comp_Rev9.dwg

Phoenix Precast Products

Phoenix Precast Products

Standard Cover Configuration
 (3) 24" Dia Concrete Covers

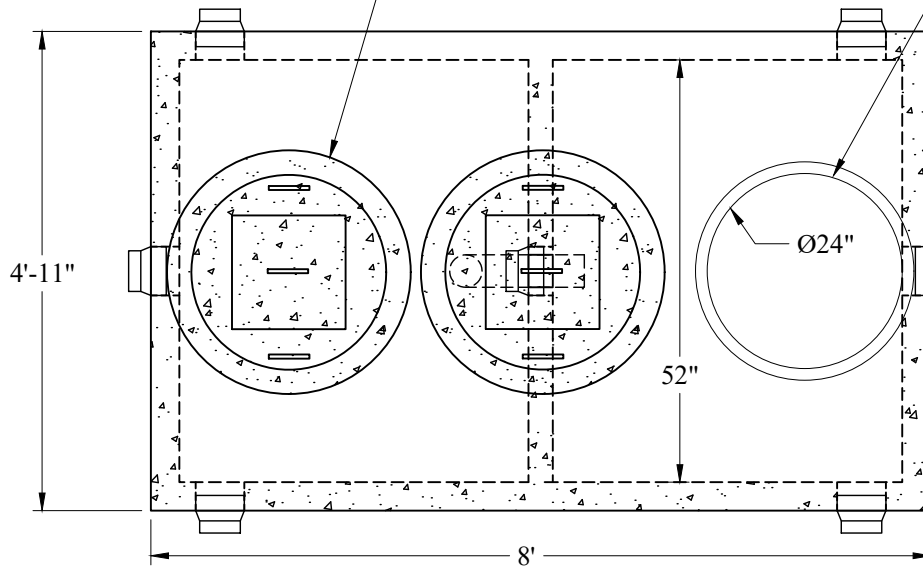

Optional Cover Configuration is
 (3) 24" Dia Plastic Risers Cast In,
 With Plastic Covers

PolyLok Boot
 6 Places

Standard
 Concrete Cover

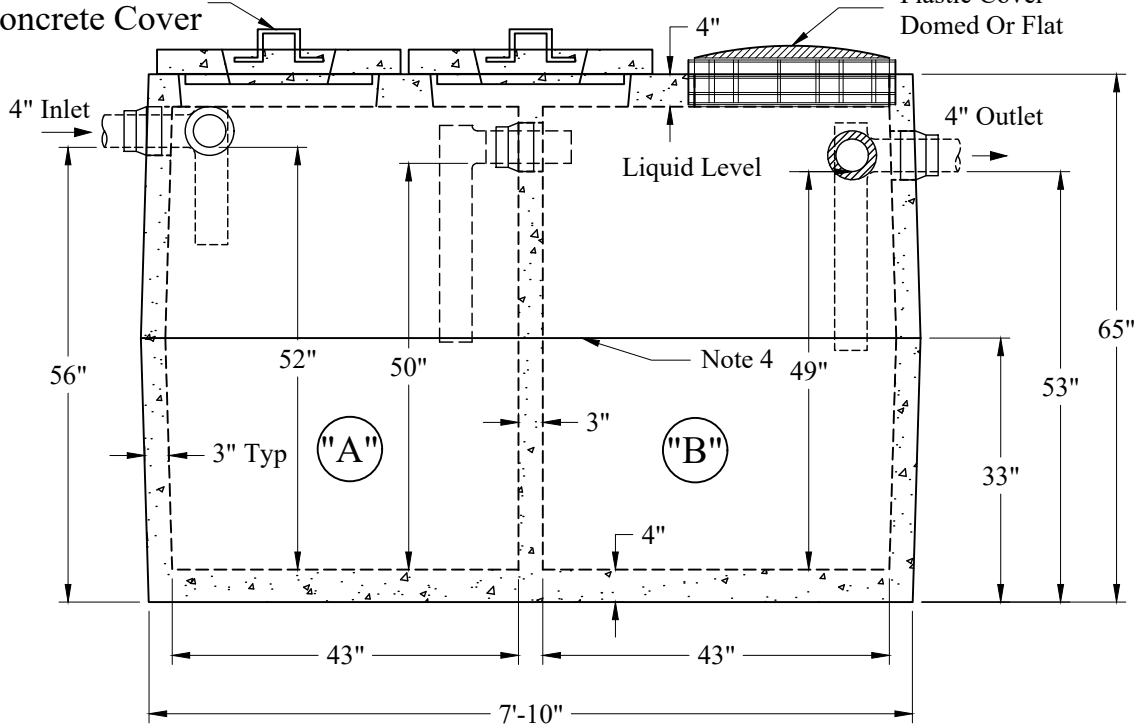

Optional
 Plastic Cover
 Domed Or Flat

"A" Liquid Level = 116 Gals/VF (10 Gals/In)

"B" Liquid Level = 116 Gals/VF (10 Gals/In)

"A" = 500 Gals

"B" = 490 Gals

Total = 990 Gals

Est Weight:

Upper: 4,400 Lbs

Lower: 4,400 Lbs

Total: 8,800 Lbs

General Notes

1. Steel Reinforcement Conforms to Latest ASTM Specifications: ASTM-A615 Grade 60 Rebar
 2. Concrete: $f_c = 4,000$ psi @ 28 Days Minimum
 3. Flexible Sleeves Used On All Pipe Openings
 4. Butyl Rubber Joint Sealant Provided
 5. Internal PVC Baffles Available
- Inlet:** Shall Penetrate at Least 9" Below the Liquid Level But Not Deeper Than the Outlet Baffle.
- Outlet:** Shall Extend Below the Surface of the Liquid Equal to 40% of the Liquid Depth (20").
6. HD Tanks: 3' -6' Cover Max, Non-Traffic

Phoenix
 Precast
 Products

500/500 Gallon LD
 2 Compartment Tank

P/N: ST-500/500LD

P/N: ST-500/500PLSLD

Concord, NH 03301