

C:\Users\trouille\OneDrive - Sabbow & Co Inc\ray r Web Site 2024\Septic_Tanks\2
 Compartment HD Mid-Seam\500-500 HD_2-Comp_Rev3.dwg

Phoenix Precast Products

Phoenix Precast Products

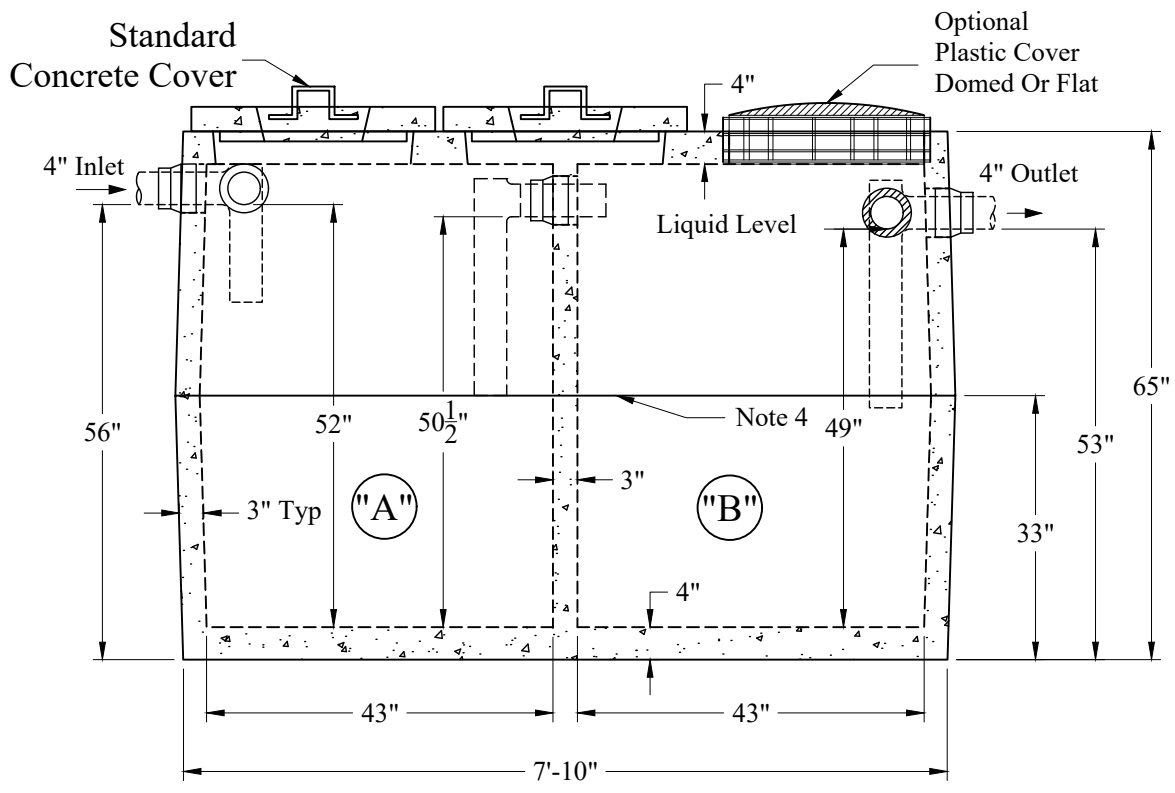
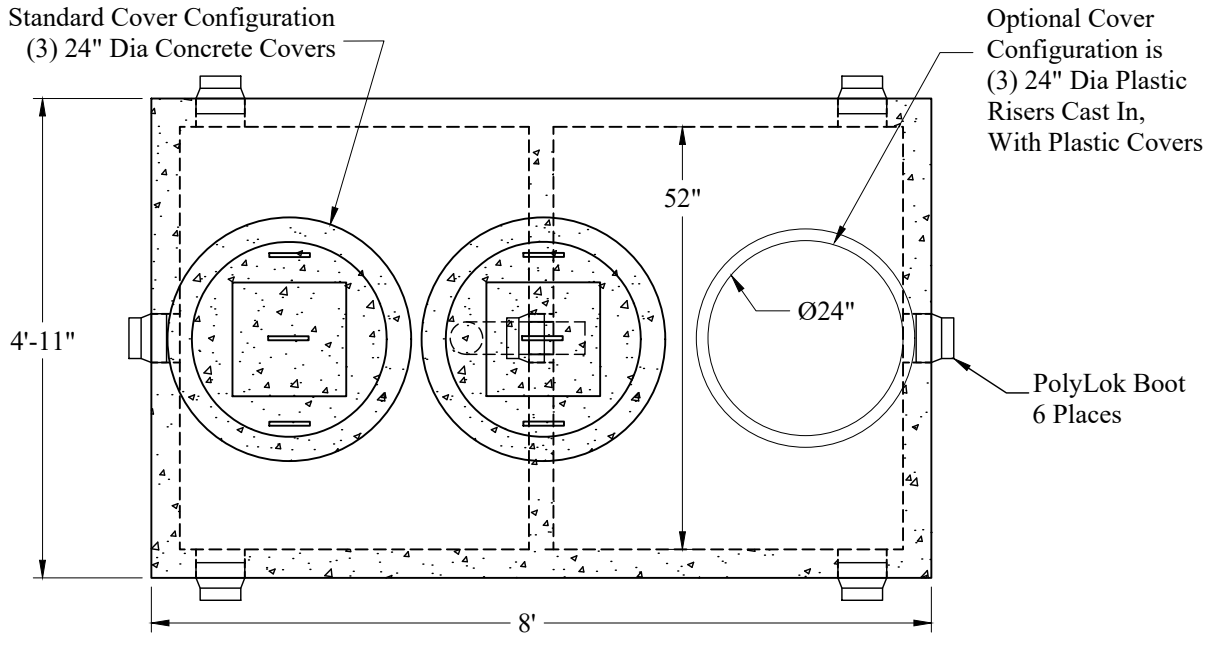

Est Weight:
 P/N: MST-500/500TOPHD Top: 4,400 Lbs
 P/N: MST-500/500TOPPLSHD: 4,400 Lbs
 P/N: MST-500/500BOTHD: 4,400 Lbs
 Total = 995 Gals Total Reg or Plastic: 8,800 Lbs

General Notes

1. Steel Reinforcement Conforms to Latest ASTM Specifications: ASTM-A615 Grade 60 Rebar
2. Concrete: $f_c = 4,000$ psi @ 28 Days Minimum
3. Flexible Sleeves Used On All Pipe Openings
4. Butyl Rubber Joint Sealant Provided
5. Internal PVC Baffles Available
- Inlet: Shall Penetrate at Least 9" Below the Liquid Level But Not Deeper Than the Outlet Baffle.
- Outlet: Shall Extend Below the Surface of the Liquid Equal to 40% of the Liquid Depth (20").
6. HD Tanks: 3' -6' Cover Max, Non-Traffic

"A" = 505 Gals
 "B" = 490 Gals
 Total = 995 Gals

Phoenix
 Precast
 Products

500/500 Gallon HD
 2 Compartment Tank

P/N: ST-500/500HD
 P/N: ST-500/500PLSHD

Concord, NH 03301